

# Invacare® Storm®<sup>4</sup> Series

Storm<sup>4</sup> Max



en Power Wheelchair  
Service Manual



PROVIDER: Keep this manual.  
The procedures in this manual MUST be performed by a qualified technician.



**Yes, you can.®**

© 2020 Invacare Corporation

All rights reserved. Reproduction, duplication or modification in whole or in part is prohibited without prior written permission from Invacare. Trademarks are identified by ™ and ®. All trademarks are owned by or licensed to Invacare Corporation or its subsidiaries unless otherwise noted.

Making Life's Experiences Possible is a registered trademark in the U.S.A.

# Contents

<b>1 General</b> . . . . .	<b>4</b>	6.9 Controls . . . . .	42
1.1 Introduction . . . . .	4	6.9.1 Replacing remote . . . . .	42
1.2 General Information . . . . .	4	6.9.2 Making Power Module Accessible . . . . .	42
1.3 Notes on Shipping . . . . .	4	6.9.3 Replacing Power Module . . . . .	42
1.4 Symbols in this Manual . . . . .	4	6.9.4 Replacing G-Trac Sensor . . . . .	43
1.5 Images in This Manual . . . . .	5	6.9.5 Replacing Actuator Module . . . . .	44
<b>2 Safety</b> . . . . .	<b>6</b>	6.9.6 Replacing Light Board . . . . .	44
2.1 Safety information . . . . .	6	6.9.7 Drive Program Selection After Component Replacement . . . . .	45
2.2 Safety and Fitting Instructions . . . . .	6	6.9.8 Updating Software . . . . .	45
<b>3 Hygiene</b> . . . . .	<b>8</b>	6.10 Batteries . . . . .	46
3.1 Handling of Returned Used Products . . . . .	8	6.10.1 General Instructions on Handling Batteries . . . . .	46
<b>4 Setup</b> . . . . .	<b>9</b>	6.10.2 Handling Damaged Batteries Correctly . . . . .	46
4.1 General information on setup . . . . .	9	6.10.3 Making Batteries Accessible . . . . .	47
4.2 Adjusting Seat Height With Seat Column Installed . . . . .	9	6.10.4 Removing Batteries . . . . .	47
4.3 Adjusting Lower Leg Length . . . . .	9	6.10.5 Main Fuse . . . . .	48
4.4 Adjusting Fixed Footboard . . . . .	9	6.10.6 Cable Routing . . . . .	49
4.5 Adjusting Backrest . . . . .	10	6.11 Lighting Unit . . . . .	50
4.5.1 Adjusting Tension-Adjustable Backrest . . . . .	10	6.11.1 Replacing front LED . . . . .	50
4.5.2 Adjusting Height of Backrest Frame . . . . .	10	6.11.2 Replacing Headlight (LED) . . . . .	50
4.5.3 Adjusting Height of Backrest Tube . . . . .	11	6.11.3 Replacing Headlight Holder (LED) . . . . .	51
4.6 Adjusting seat tilt . . . . .	11	6.11.4 Replacing Complete Rear Light (LED) . . . . .	52
4.6.1 Adjusting Seat Tilt on a Seat With Manual Tilt Module . . . . .	11	6.12 Seating . . . . .	53
4.7 Adjusting Seat Depth . . . . .	11	6.12.1 Replacing Seat Frame . . . . .	53
<b>5 Testing</b> . . . . .	<b>12</b>	6.12.2 Replacing Tilt Spindle . . . . .	54
5.1 Testing Motor . . . . .	12	6.12.3 Replacing Tilt Actuator . . . . .	54
5.2 Testing Motor Brake . . . . .	12	6.12.4 Replacing Tilt Bracket . . . . .	55
5.3 Rain test . . . . .	12	6.12.5 Replacing Seat Support . . . . .	55
5.4 Field Load Test . . . . .	13	6.12.6 Replacing Seat Column . . . . .	56
5.5 Checking Actuator . . . . .	13	6.13 Headrest/Neckrest . . . . .	57
5.6 Checking Battery Charge Level . . . . .	14	6.13.1 Replacing Rea Headrest . . . . .	57
<b>6 Service</b> . . . . .	<b>15</b>	6.13.2 Replacing Rea Headrest Mounting Bracket (Sling Backrest) . . . . .	57
6.1 General warning information on installation work . . . . .	15	6.14 Replacing legrests . . . . .	58
6.2 Tightening Torques . . . . .	15	6.14.1 Replacing Footboard/Legrest Holder . . . . .	58
6.3 Overview Mobility Device . . . . .	15	6.14.2 Replacing Fixed Footboard . . . . .	58
6.4 Troubleshooting . . . . .	16	6.14.3 Replacing Calf Pads . . . . .	59
6.4.1 Operational Faults . . . . .	16	6.15 Armrests . . . . .	60
6.4.2 Drive Fault Diagnosis . . . . .	16	6.15.1 Replacing Armrest . . . . .	60
6.4.3 Charging device fault diagnosis . . . . .	19	6.16 Backrest . . . . .	62
6.5 Service Plan . . . . .	19	6.16.1 Replacing Backrest Tube . . . . .	62
6.6 Shrouds . . . . .	21	6.16.2 Replacing Backrest Frame . . . . .	62
6.6.1 Replacing Rear Shroud . . . . .	21	6.16.3 Replacing Backrest Rail . . . . .	62
6.6.2 Replacing Centre Shroud . . . . .	21	6.16.4 Replacing Seat Depth Adapter . . . . .	63
6.6.3 Replacing Front Shroud . . . . .	22	6.16.5 Replacing Backrest Bracket . . . . .	64
6.6.4 Replacing Rear Light Shroud . . . . .	22	6.17 Posture Belt . . . . .	65
6.6.5 Replacing Fender . . . . .	23	6.17.1 Replacing Posture Belt . . . . .	65
6.7 Drive Components . . . . .	23		
6.7.1 Replacing Drive Unit . . . . .	23		
6.7.2 Replacing Carbon Brushes . . . . .	24		
6.7.3 Replacing Bowden Cables and Clutch . . . . .	26		
6.7.4 Replacing Motor Swing Arm . . . . .	27		
6.7.5 Replacing Suspension Strut . . . . .	28		
6.7.6 Replacing Front Swing Arm . . . . .	29		
6.7.7 Replacing Castor Fork . . . . .	30		
6.7.8 Adjusting Castor Fork . . . . .	30		
6.8 Wheels . . . . .	31		
6.8.1 Repair Instructions . . . . .	31		
6.8.2 Tyre Pressure . . . . .	31		
6.8.3 Tyre Types . . . . .	32		
6.8.4 Specific Tightening Torques . . . . .	32		
6.8.5 Overview of Power Wheelchair Models and Wheel Types . . . . .	33		
6.8.6 Replacing Drive Wheel (5-Screw Installation) . . . . .	34		
6.8.7 Replacing Castor Wheel on Double-Sided Fork . . . . .	35		
6.8.8 Replacing Flat Castor Tyre / Inner Tube . . . . .	38		
6.8.9 Replacing Drive Wheel Hub . . . . .	41		
6.8.10 Replacing Big Anti-Tipping Wheel . . . . .	41		
6.8.11 Replacing Small Anti-Tipping Wheel . . . . .	41		

# 1 General

## 1.1 Introduction

This document contains important information about assembly, adjustment and advanced maintenance of the product. To ensure safety when handling the product, read this document and the user manual carefully and follow the safety instructions.

Find the user manual on Invacare's website or contact your Invacare representative. See addresses at the end of this document.

Invacare reserves the right to alter product specifications without further notice.

Before reading this document, make sure you have the latest version. You find the latest version as a PDF on the Invacare website.

For pre-sale and user information, see the user manual.

For more information about the product, for example product safety notices and product recalls, contact your Invacare representative. See addresses at the end of this document.

## 1.2 General Information

Service and maintenance work must be carried out taking this document into account.

It is imperative that you observe safety information.

Information about operation or about general maintenance and care work on the product should be taken from service manual.

Assembly of accessories might not be described in this document. Refer to the manual delivered with the accessory. Additional manuals can be ordered from Invacare. See addresses at the end of this document.

You can find information about ordering spare parts in the spare parts catalogue.

Spare parts must match original Invacare parts. Only use spare parts which have been approved by Invacare.

The product may only be maintained and overhauled by qualified personnel.

The minimum requirement for service technicians is suitable training, such as in the cycle or orthopedic mechanics fields, or sufficiently long-term job experience. Experience in the use of electrical measuring equipment (multimeters) is also a requirement. Special Invacare training is recommended.

Alterations to the mobility device which occur as a result of incorrectly or improperly executed maintenance or overhaul work lead to the exclusion of all liability on the side of Invacare.

If you have any problems or questions contact your provider.

## 1.3 Notes on Shipping

- If the mobility device has to be shipped back to the manufacturer for major repairs, you should always use the original packaging for transport.
- Please attach a precise description of the fault.

## 1.4 Symbols in this Manual

Symbols and signal words are used in this manual and apply to hazards or unsafe practices which could result in personal injury or property damage. See the information below for definitions of the signal words.



**DANGER**

Indicates a hazardous situation that will result in serious injury or death if it is not avoided.



**WARNING**

Indicates a hazardous situation that could result in serious injury or death if it is not avoided.



**CAUTION**

Indicates a hazardous situation that could result in minor or slight injury if it is not avoided.



**IMPORTANT**

Indicates a hazardous situation that could result in damage to property if it is not avoided.



Gives useful tips, recommendations and information for efficient, trouble-free use.



Identifies required tools, components and items which are needed to carry out certain work.

## 1.5 Images in This Manual

The detailed images in this manual are given marks to identify various components. Component marks in text and operational instructions always relate to the image directly above.

## 2 Safety

### 2.1 Safety information



**WARNING!**

The procedures in this service manual, must be performed by a specialized dealer or qualified service technician.

- Do not handle this product or any available optional equipment without first completely reading and understanding these instructions and any additional instructional material such as user manuals, installation manuals or instruction sheets supplied with this product or optional equipment.



The information contained in this document is subject to change without notice.

### 2.2 Safety and Fitting Instructions

These safety instructions are intended to prevent accidents at work, and it is imperative that they are observed.

#### Before any inspection or repair work

- Read and observe this repair manual and the associated user manual.
- Observe the minimum requirements for carrying out the work (see 1.2 *General Information, page 4*).

#### Personal Safety Equipment

##### Safety shoes

The mobility device, and some of its components, are very heavy. These parts can result in injuries to the feet if they are allowed to drop.

- Wear standardized safety shoes during all work.

##### Eye protection

It is possible that battery acid can be discharged when working on defective batteries or when handling batteries improperly.

- Always wear eye protection when working on any defective or possibly defective batteries.

##### Safety gloves

It is possible that battery acid can be discharged when working on defective batteries or when handling batteries improperly.

- Always wear acid-proof safety gloves when working on any defective or possibly defective batteries.

#### General Safety Information and Information About Fitting / Removal



**DANGER!**

**Risk of Death, Serious Injury, or Damage**

Lighted cigarettes dropped onto an upholstered seating system can cause a fire resulting in death, serious injury, or damage. Mobility device occupants are at particular risk of death or serious injury from these fires and resulting fumes because they may not have the ability to move away from the mobility device.

- DO NOT smoke while using this mobility device.



**WARNING!**

**Risk of Serious Injury or Damage**

Storing or using the mobility device near open flame or combustible products can result in serious injury or damage.

- Avoid storing or using the mobility device near open flame or combustible products.



**CAUTION!**

**Risk of crushing**

Various components such as the drive unit, batteries, seat etc are very heavy. This results in injury hazards to your hands.

- Note the high weight of some components. This applies especially to the removal of drive units, batteries and the seat.



**CAUTION!**

**Injury hazard if the mobility device starts moving unintentionally during repair work**

- Switch the power supply off (ON/OFF key).
- Engage the drive.
- Before lifting up, secure the mobility device by using chocks to block the wheels.

**CAUTION!****Fire and burn hazard due to electrical short-circuit**

- The mobility device must be completely switched off before removal of voltage-carrying components! To do this, remove the batteries.
- Avoid short-circuiting the contacts when carrying out measurements on voltage-carrying components.

**CAUTION!****Risk of burns from hot surfaces on the motor**

- Allow the motors to cool down before commencing work on them.

**CAUTION!****Injury hazard and risk of damage to mobility device due to improper or incomplete maintenance work**

- Use only undamaged tools in good condition.
- Some moving parts are mounted in sockets with PTFE coating (Teflon™). Never grease these sockets!
- Never use "normal" nuts instead of self-locking nuts.
- Always use correctly-dimensioned washers and spacers.
- When reassembling, always replace any cable ties which were cut during dismantling.
- After completing your work / before renewed start-up of the mobility device, check all connections for tight fitting.
- After completing your work / before renewed start-up of the mobility device, check all parts for correct locking.
- Only operate the mobility device with the approved tyre pressures (see technical data).
- Check all electrical components for correct function. Note that incorrect polarity can result in damage to the control system.
- Always carry out a trial run at the end of your work.

**CAUTION!****Risk of injury and damage to property, if the maximum speed reduction on a wheelchair with a lifter does not function correctly**

The wheelchair's control unit must reduce the maximum possible speed as soon as the lifter is raised.

- Test the maximum speed reduction for correct function after any maintenance work or modifications to the wheelchair.

**CAUTION!****Any changes to the drive program can affect the driving characteristics and the tipping stability of the mobility device**

- Changes to the drive program may only be carried out by trained Invacare providers.
- Invacare supplies all mobility devices with a standard drive program ex-works. Invacare can only give a warranty for safe mobility device driving behavior - especially tipping stability - for this standard drive program.



Mark all current settings for the mobility device (seat, armrests, backrest etc.), and the associated cable connecting plugs, before dismantling. This makes reassembly easier. All plugs are fitted with mechanical locks which prevent release of the connecting plugs during operation. To release the connecting plugs the safety locks must be pressed in. When reassembling ensure that these safety locks are correctly engaged.

## 3 Hygiene

### 3.1 Handling of Returned Used Products

When reconditioning or repairing returned mobility devices:

- Take precautions for yourself and the product.
- Use protection equipment as specified locally.

#### Before Transport (According to Biological Agents Ordinance)

Treat product according to following process steps:

Process Step	Component	Application	Conditioning technique	Work Station
Manual cleaning	Surface of used device	Before repair or reconditioning	Use saturated towel to apply cleaning detergent and remove residues after impact.	Cleaning and disinfection
Disinfection	Surface of used device	Before repair or reconditioning	Use saturated disinfectant wipes and clean* the device surface.	Cleaning and disinfection

\*Invacare uses detergent "Nücosept special" 1.5% in water ml/ml

#### Disinfection Tools

- Disposable wipes (fleece)
- Brushes to clean areas difficult to access

#### Further Information

 For more information contact your Invacare service department.



## 4 Setup

### 4.1 General information on setup

The tasks described in this chapter are intended to be performed by trained and authorized service technicians for initial setup. They are not intended to be performed by the user.

### 4.2 Adjusting Seat Height With Seat Column Installed



**CAUTION!**

**Risk of crushing**

The seat is very heavy. Risk of injury to hands and feet.  
– Use proper lifting techniques.



**CAUTION!**

**Risk of crushing**

Risk of injury caused by uncontrolled movement of mobility device.  
– Switch off power supply (ON/OFF key).  
– Engage drive.



- 4 mm Allen key
- TX40 Torx key
- Oblique pliers
- Cable ties

#### Manual Seat Height Adjustment

1. Remove seat. See 6.12.5 *Replacing Seat Support*, page 55.
2. Loosen and remove four screws (2) on the upper side of column (3).
3. Lift off shroud plate (1).
  -  The shroud plate has four flaps pointing downward. There are two tapped holes on each flap for screws (2). By selecting upper or lower holes, seat can be adjusted to two different heights.
4. Attach shroud plate (1).
5. Install screws (2) in such a way that shroud plate is flush fitted or is somewhat elevated depending on desired seat height.
6. Install parts in reverse order.
7. Check all mobility device functions.

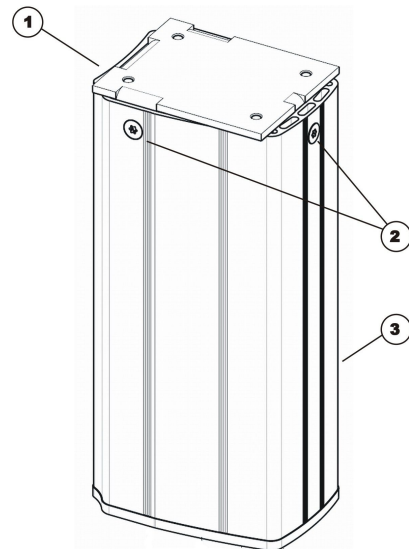

Fig. 4-1

### 4.3 Adjusting Lower Leg Length

Invacare offers a range of legrests which can be adjusted individually. See user manual.

### 4.4 Adjusting Fixed Footboard



- 5 mm Allen key

1. Loosen four screws (A) on both sides.
2. Adjust lower footboard assembly (B) to desired length.
3. Re-tighten screws (A).

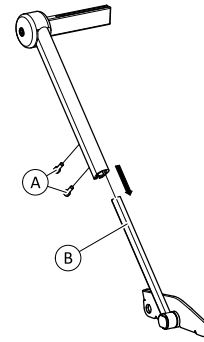

Fig. 4-2

## 4.5 Adjusting Backrest



### CAUTION!

**Adjusting the seat tilt or the backrest angle changes the geometry of the mobility device and directly influences its dynamic stability!**

– For details regarding dynamic stability, negotiating gradients and obstacles and the correct adjustment of seat tilt or backrest angle, refer to *Taking Obstacles* and *Driving up and down Gradients*.

### 4.5.1 Adjusting Tension-Adjustable Backrest

The tension-adjustable backrest can be individually adapted to the user's back shape.

1. Pull front and rear faces of backrest upholstery (1) apart and remove. Backrest upholstery front and rear faces are held together using hook-and-loop straps.
2. Open hook-and-loop straps of backrest belt (2) and adjust to required length.
3. Re-install backrest upholstery and fix it with hook-and-loop straps.

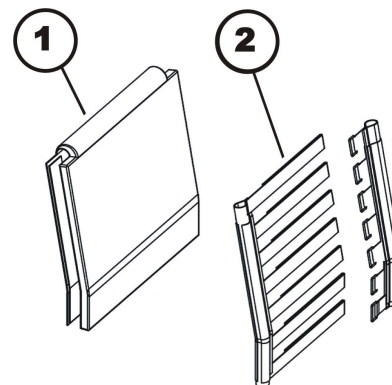

Fig. 4-3

### 4.5.2 Adjusting Height of Backrest Frame

The following describes only how to adjust the height of the backrest frame. For further adjustments of the backrest frame to user needs see the corresponding user manual.



- 5 mm Allen key

1. Raise backrest tube as far as possible. See 4.5.3 *Adjusting Height of Backrest Tube*, page 11.
2. Loosen screws (A).
3. Move backrest frame (B) to desired height.
4. Re-tighten screws (A).
5. Lower backrest tube and re-tighten handscrews.



Fig. 4-4

### 4.5.3 Adjusting Height of Backrest Tube

1. Loosen handscrews on both sides.
2. Adjust backrest tube to desired height.
3. Re-tighten handscrews.

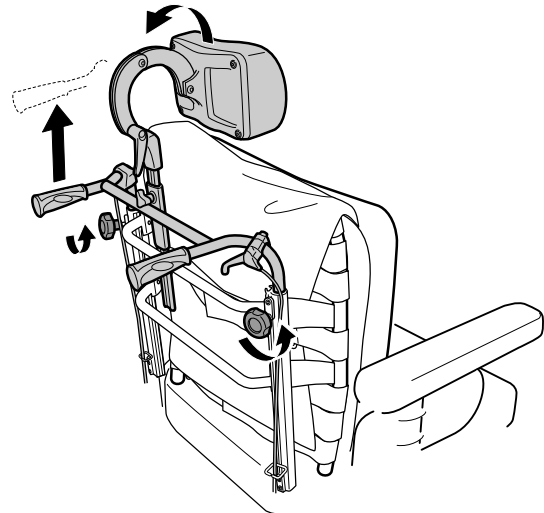

Fig. 4-5

## 4.6 Adjusting seat tilt

### 4.6.1 Adjusting Seat Tilt on a Seat With Manual Tilt Module



**CAUTION!**  
**Risk of crushing**

Seat and frame are very heavy and can fall down without warning if seat tilt adjustment assembly is screwed apart too far. Risk of injury to hands and feet.

– Only change adjustments when nobody is seated in chair.

– Only change tilt adjustment to where distance between axles is a maximum of 300 mm.



- 19 mm wrench
- Measuring tape

1. Apply wrench to bolt (1) of tilt adjustment.
2. Turn tilt adjustment till desired angle is attained or distance between bolts is a maximum of 300 mm.

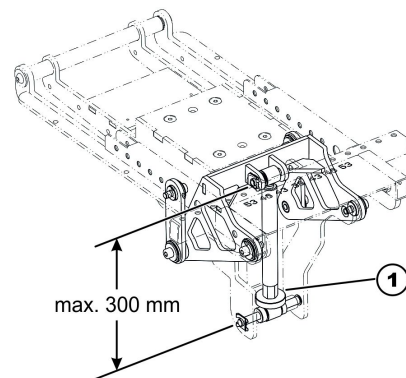

Fig. 4-6

## 4.7 Adjusting Seat Depth

See corresponding user manual.

## 5 Testing

### 5.1 Testing Motor

 The testing procedure does not apply to True Track® Plus motors. In the case of the True Track® Plus motor, the cable plug is connected directly to the motor.

 • Digital multimeter with resistance measurement

1. Remove rear shroud as described in *6.6.1 Replacing Rear Shroud, page 21*.
2. Pull the motor plug out of power module.
3. Connect the digital multimeter to the motor plug contacts (3) and measure the resistance between the contacts.

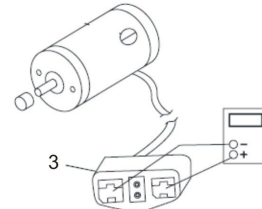



Fig. 5-1

 A resistance of between 0.5 ohms and 5.0 ohms indicates a motor ready for operation. A resistance of between 15.0 ohms and infinity indicates a defective motor. High resistances are normally caused by bad connections or worn carbon brushes.

### 5.2 Testing Motor Brake

 This test should only be carried out on mobility devices with conventional motor/gearbox units.



#### CAUTION!

#### Risk of damage to power module due to shorts in motor brake

- Never connect a shorted motor brake to an intact power module.
- Always replace shorted brakes immediately.

 A defective motor can damage the power module, but a defective power module cannot damage the motor.

 • Phillips screwdriver, size 2  
• Digital multimeter with resistance measurement

1. Remove rear shroud as described in *6.6.1 Replacing Rear Shroud, page 21*.
2. Pull motor plug out of the power module.
3. Connect the digital multimeter to the adjacent central motor plug contacts (3) and measure the resistance between the contacts.
4. If there is a defect, replace the motor and send it to Invacare Service for inspection or repair.

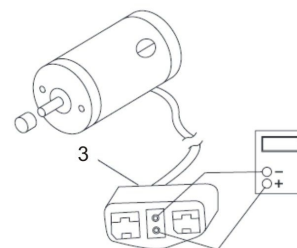



Fig. 5-2

 A resistance of between 40 ohms and 80 ohms indicates an intact brake. A resistance of 0 ohms or a very high resistance (mega-ohms or infinity) indicates a short-circuit, a bad connection or a defective brake.

### 5.3 Rain test

- Check to ensure that the black battery terminal caps are secured in place, gaiter is not torn or cracked where water can enter and that all electrical connections are secure at all times.
- Do not use the mobility device if the gaiter is torn or cracked. If the gaiter becomes torn or cracked, replace immediately.

## 5.4 Field Load Test

Old batteries lose their ability to store and release power due to increased internal resistance. In this procedure, batteries are tested under load using a digital voltmeter to check battery charge level at the charger connector. The charger connector is located on the remote. When voltage at the output drops 1.0 volts under load (2.0 volts for a pair), replace the batteries.

 Read these instructions carefully and the manufacturer's instructions on the digital voltmeter before proceeding.



- Voltmeter



### WARNING!

– When performing the following steps, ensure your feet are clear from casters and wall, otherwise injury may result.

1. Switch electronics OFF on remote.
2. Make sure battery is fully charged. An extremely discharged battery will exhibit the same symptoms as a bad battery.
3. Remove footboard/legrests from mobility device.
4. Connect voltmeter leads to charger connector **(A)** on mobility device. Most digital voltmeters **(B)** are not affected by polarity. However, analog meters (meters with swinging needles) can be and should be used carefully.

 A good meter reading should be 25.5 VDC to 26.0 VDC with the chair in neutral.

5. Switch electronics ON on remote.
6. Ensure that your feet are clear from casters and wall.
7. Run mobility device in neutral for at least 2 minutes.
8. Sit in mobility device and place your feet against a door jam, workbench or other stationary object.
9. Carefully give forward command, trying to drive the mobility device through the stationary object. The load should draw between 30 amps to 40 amps from the batteries for 0.3 seconds.

 Performing this step puts a heavy load on the batteries as they try to push through the stationary object. If the wheels spin, have two individuals (one on each arm) apply as much downward pressure as possible on the arms of the mobility device.

10. Read meter while motors are straining to determine voltage under load.

 If the voltage drops more than 2.0 volts from a pair of fully charged batteries during the 0.3 seconds, they should be replaced regardless of the unloaded voltages.

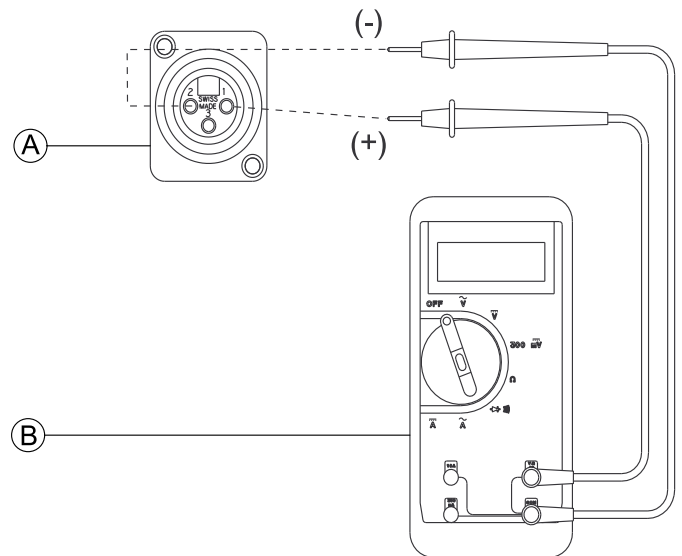

Fig. 5-3

## 5.5 Checking Actuator



- Digital multimeter with resistance measurement



1. Turn OFF controls on remote.
2. If necessary, remove shroud.
3. Take note of the positions of all cables and sockets that they are connected to. Mark connectors and sockets or take a photograph with a digital camera.
4. Unplug actuator.
5. Connect multimeter to the contacts and measure the resistance between the contacts. The plug can have a different shape than shown in illustration.

 A resistance below 1 ohms indicates a short-circuit. Very high resistances indicates (mega-ohms or infinity) indicates a defective actuator. Actuator must be replaced in both cases.

## 5.6 Checking Battery Charge Level

The following “Dos” and “Don’ts” are provided for your convenience and safety.

DON'T	DO
Don't perform any installation or maintenance without first reading this manual.	Read and understand this manual and any service information that accompanies a battery and charger before operating the personal transporter.
Don't perform installation or maintenance of batteries in an area that could be damaged by battery spills.	Move the personal transporter to a work area before cleaning terminals, or opening battery box.
Don't make it a habit to discharge batteries to the lowest level.	Recharge as frequently as possible to maintain a high charge level and extend battery life.
Don't use chargers or batteries that are not appropriate for the chair.	Follow recommendations in this manual when selecting a battery or charger.
Don't put new batteries into service before charging.	Fully charge a new battery before using.
Don't tip or tilt batteries.	Use a carrying strap to remove, move or install a battery.
Don't tap on clamps and terminals with tools.	Push battery clamps on the terminals. Spread clamps wider if necessary.

## 6 Service

### 6.1 General warning information on installation work



**CAUTION!**

**Risk of injury and damage to property, if the maximum speed reduction on a mobility device with a lifter does not function correctly**

The mobility device's control unit must reduce the maximum possible speed as soon as the lifter is raised.

- Test the maximum speed reduction for correct function after any maintenance work or modifications to the mobility device.

### 6.2 Tightening Torques



**CAUTION!**

**Risk of damage to mobility device due to improperly tightened screws, nuts or plastic connections.**

- Always tighten screws, nuts etc. to the stated tightening torque.
- Only tighten screws or nuts which are not listed here fingertight.

The tightening torques stated in the following list are based on the thread diameter for the nuts and bolts for which no specific values have been determined. All values assume dry and de-greased threads.

Thread	Tightening Torque in Nm $\pm 10\%$
M4	3 Nm
M5	6 Nm
M6	10 Nm
M8	25 Nm
M10	49 Nm
M12	80 Nm
M14	120 Nm
M16	180 Nm

### 6.3 Overview Mobility Device

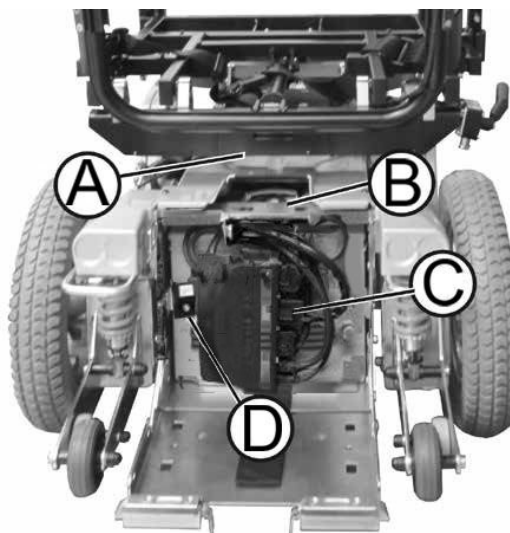

Fig. 6-1

The electronics is situated at the rear underneath the rear shroud and directly under the seat.

#### Under Seat

- Ⓐ Actuator module (optional)

If present, it controls the powered tilt module as well as the powered recline.



On LiNX systems there is no actuator module available. Tilt and Recline are controlled directly by the power module.

## Under Rear Shroud

- Ⓑ Light board (optional) It is located on top of the battery box. It is only present if the wheelchair is equipped with a lighting system.
- Ⓒ Power module It is located in the rear inside of the battery box.
- Ⓓ G-Trac sensor (optional) It is located inside of the battery box directly next to the power module.

## 6.4 Troubleshooting

### 6.4.1 Operational Faults

Proceed as follows if you have any problems:

1. First assess the possible cause of the problem using the following table.
2. Check the remote status display. Evaluate the flash error code.
3. Carry out the necessary checks and repairs as recommended in the following table.

The various power modules can be fitted in connection with different remotes in the mobility device. Rectification of operational faults depends on the power module fitted. The power modules used are described in the corresponding controls manual.

 The tables for rectification of operational faults listed in the following chapters are only an excerpt from the original manufacturer's manuals. You can obtain the original manuals from Invacare.

### 6.4.2 Drive Fault Diagnosis

Problem	Other symptoms	Possible cause	Solution	Documentation
<b>Mobility device will not start</b>	The remote status display illuminates normally and shows an error code.	Drive motors disengaged	Engage drive motors	See user manual
	Remote status display does not illuminate	Batteries defective	Replace batteries	See 6.10 Batteries, page 46
		Completely discharge battery	Pre-charge batteries	See user manual
		Power supply to remote interrupted	Check main fuse	See 6.10.5 Main Fuse, page 48
			Check cables between modules for loose connections or damage	See 6.10.6 Cable Routing, page 49
	Remote defective	Replace remote	See corresponding remote manual	
Remote status display flashing	Various causes	Assess error code	See corresponding remote manual	
<b>Mobility device judders in drive mode</b>	None	Batteries defective (unstable voltage)	Replace batteries	See 6.10 Batteries, page 46
		Drive motor(s) defective	Replace motor(s)	See 6.7.1 Replacing Drive Unit, page 23
			Replace carbon brushes	See 6.7.2 Replacing Carbon Brushes, page 24
<b>Mobility device pulls to left or right</b>	None	Drive motors running asymmetrically	Change programming to synchronise motors	See 6.9.8 Updating Software, page 45
	Tyre visibly dented	Not enough air in tyre	Check air pressure, replace inner tube and/or valve if necessary.	See 6.8.3 Tyre Types, page 32



Problem	Other symptoms	Possible cause	Solution	Documentation
<b>Error message does not go out</b>	None	Bad connections	Check all connecting cables.	See 6.10.6 <i>Cable Routing</i> , page 49
		Motor brake defective	Measure internal resistance of brakes, replace motor if defective.	See 6.7.1 <i>Replacing Drive Unit</i> , page 23
<b>Motors stop and start again</b>	None	Voltage decline	Stop driving and allow controls to cool down.	
<b>Motor runs but loses power</b>	None	High motor load allows power module to lower voltage	Stop driving and allow controls to cool down.	
<b>Motors stop and do not start again</b>	None	High motor load allows power module to lower voltage	Leave mobility device switched on and let power module operate. Charge batteries overnight with mobility device switched on.	
	None	Fuse burnt out	Check wiring and replace fuse	See 6.10.6 <i>Cable Routing</i> , page 49 and 6.10.5 <i>Main Fuse</i> , page 48
	None	Motor defective	Check carbon brushes and replace if necessary	See 6.7.2 <i>Replacing Carbon Brushes</i> , page 24
			Measure internal resistance of motor, replace motor if defective.	See 6.7.1 <i>Replacing Drive Unit</i> , page 23
	None	Power module defective	Replace power module	See 6.9.3 <i>Replacing Power Module</i> , page 42
<b>Motors lose power while driving</b>	None	Bad connections	Switch mobility device off, wait 10 seconds, switch mobility device on again. Check all wiring.	See 6.10.6 <i>Cable Routing</i> , page 49
<b>Motor judders or runs irregularly, or only one motor runs</b>	None	Carbon brushes worn	Check carbon brushes and replace if necessary	See 6.7.2 <i>Replacing Carbon Brushes</i> , page 24
		Bearing defective	Replace motor	See 6.7.1 <i>Replacing Drive Unit</i> , page 23
		Collector defective	Measure internal resistance of motor, replace motor if defective	See 6.7.1 <i>Replacing Drive Unit</i> , page 23

<b>Problem</b>	<b>Other symptoms</b>	<b>Possible cause</b>	<b>Solution</b>	<b>Documentation</b>
<b>Motors do not run</b>	None	Bad connections	Check all wiring	See 6.10.6 <i>Cable Routing</i> , page 49
		Fuse burnt out	Check wiring and replace fuse	See 6.10.6 <i>Cable Routing</i> , page 49 and 6.10.5 <i>Main Fuse</i> , page 48
		Batteries defective	Replace batteries	See 6.10 <i>Batteries</i> , page 46
		Wiring to power module or remote defective	Check wiring	See 6.10.6 <i>Cable Routing</i> , page 49
		Power module defective	Replace power module	See 6.9.3 <i>Replacing Power Module</i> , page 42
	Corroded contacts	Water, salt or urine has penetrated	Check wiring, replace if necessary	See 6.10.6 <i>Cable Routing</i> , page 49
<b>Motor makes clicking noise</b>	None	Bearing defective	Replace motor	See 6.7.1 <i>Replacing Drive Unit</i> , page 23
		Collector defective	Measure internal resistance of motor, replace motor if defective	See 6.7.1 <i>Replacing Drive Unit</i> , page 23
<b>Scraping noise or motor blocked</b>	None	Bearing defective	Replace motor	See 6.7.1 <i>Replacing Drive Unit</i> , page 23
		Transmission defective	Replace transmission	See 6.7.1 <i>Replacing Drive Unit</i> , page 23
<b>Transmission makes clicking noise</b>	None	Transmission defective	Replace transmission	See 6.7.1 <i>Replacing Drive Unit</i> , page 23
		Drive wheel loose	Tighten drive wheel, secure bolts with thread locking adhesive, if necessary	See 6.8.6 <i>Replacing Drive Wheel (5-Screw Installation)</i> , page 34
<b>Transmission losing oil</b>	None	Sealing ring on drive shaft defective	Replace transmission if sealing ring defective	See 6.7.1 <i>Replacing Drive Unit</i> , page 23
			Check carbon brushes for oil wetting, replace motor if brushes wet	See 6.7.1 <i>Replacing Drive Unit</i> , page 23 and 6.7.2 <i>Replacing Carbon Brushes</i> , page 24
<b>Irregular running</b>	None	Drive shaft movable or bent	Check drive shaft, replace transmission if defective	See 6.7.1 <i>Replacing Drive Unit</i> , page 23
<b>Parts lost</b>	None	Parts lost	Re-attach parts once found	
<b>Batteries not being charged</b>	None	Fuse burnt out, cable defective	Check wiring and replace fuse	See 6.10.6 <i>Cable Routing</i> , page 49 and 6.10.5 <i>Main Fuse</i> , page 48
		Batteries defective	Replace batteries	See 6.10 <i>Batteries</i> , page 46
	LEDs blinking on charging unit	Charging unit defective	Replace charging unit	See user manual
<b>Short charging period</b>	None	One of the batteries could be defective	Replace batteries	See 6.10 <i>Batteries</i> , page 46

Problem	Other symptoms	Possible cause	Solution	Documentation
Mobility device runs too slowly	None	Remote defective	Replace remote	See corresponding remote manual
		Batteries defective	Replace batteries	See 6.10 Batteries, page 46
Actuator does not react	Remote shows flash code 2. Status diode on lighting or actuator module does not go out even if remote has been switched off or disconnected	Lighting / actuator module defective	Replace lighting / actuator module	See 6.9.6 Replacing Light Board, page 44 and 6.9.5 Replacing Actuator Module, page 44
		None	Cable disconnected or damaged	Check wiring, replace if necessary
	None	Electrical adjusting motor defective	Check adjusting motor	See 5.5 Checking Actuator, page 13
	None	Remote defective	Replace remote	See 6.9.1 Replacing remote, page 42

### 6.4.3 Charging device fault diagnosis

Symptom	Possible cause	Solution
No LEDs illuminating on battery charger	Charging device not connected to mains supply.	Ensure that the battery charger has been plugged in.
	No mains supply	Check the mains supply with a voltmeter.
	Defective mains supply cable.	Check the mains supply cable. Replace damaged cables or send the battery charger to Invacare Service for repair.
	LEDs are burnt out	Send the battery charger to Invacare Service for repair.
	An internal fuse might be burnt out.	Send the battery charger to Invacare Service for repair.
Batteries do not charge	Fuse on mobility device has burnt out.	Check mobility device fuses. See “Main fuse”.
	Battery charger not connected to mobility device.	Ensure that the battery charger has been connected to the mobility device.
	No mains supply	Check the mains supply with a voltmeter.
	Defective mains supply cable.	Check the mains supply cable. Replace damaged cables or send the battery charger to Invacare Service for repair.
	Battery charger could be defective.	Use a battery charger which you know is working properly to charge the batteries. Send the defective battery charger to Invacare Service for repair.
	Battery voltage is too low to operate mobility device.	Replace the batteries. See “Removing batteries”

## 6.5 Service Plan



### CAUTION!

**Danger of injury and damage to property, if the maximum speed reduction on a wheelchair with a lifter does not function correctly!**

The wheelchair's control unit must reduce the maximum possible speed as soon as the lifter is raised.

- Test the maximum speed reduction for correct function after any maintenance work or modifications to the wheelchair.

Component	Check	Remedy	Notes	✓
Posture belt	Damage to posture belt	Replace belt if damaged	See 6.17 Posture Belt, page 65.	
	Belt lock function	Replace belt if damaged	See 6.17 Posture Belt, page 65.	
Armrests	Damage to armrests	Replace shroud if damaged		
	Armrest fixings	Tighten screws		
Side panels	Damage to side panels	Replace side panels if damaged		
	Side panel fixings	Tighten screws		
Seat lock	Seat lock defective	Replace seat lock		
Seat angle adjustment	Tight fit of the pin retainers	Replace pin retainers if necessary		
Lifter	Check screws	Tighten screws		
Power backrest (if installed)	Damage to backrest	Replace parts if damaged		
	Seams			
	Fixing	Tighten screws		
	Check cable	Replace motor cable if necessary		
	Check function			
Frames (chassis) / battery mounting	Check fixings, welded seams and battery mounting	Tighten screws		
		Replace components if necessary		
Wheel suspension and wheels	Check drive wheels for tight fit and side play	Adjust, replace wheel hubs	See 6.8.6 Replacing Drive Wheel (5-Screw Installation), page 34 and 6.8.9 Replacing Drive Wheel Hub, page 41.	
	Check steering wheels for tight fit, float and side play	Replace wheels, wheel fork or wheel bearings	See 6.7.7 Replacing Castor Fork, page 30.	
	Tyres	Repair or replace if damaged	See 6.8.3 Tyre Types, page 32.	
	Check suspension	Repair or replace if damaged	See 6.7.5 Replacing Suspension Strut, page 28.	
	Check straight running	Replace wheels, wheel fork or wheel bearings	See 6.7.7 Replacing Castor Fork, page 30.	
Drive units, clutch mechanism	Motors	Check motors		
	Check functions in drive and push modes	Check carbon brushes, replace if necessary		
	Check clutch mechanism	Replace motor if necessary		
		Tighten screws/nuts, adjust or replace if necessary	See 6.7.1 Replacing Drive Unit, page 23.	
Brakes	Inspect motor brake	Check motor brake		
Legrests	Check welded seams, interlocking, screws, footplates	Tighten, replace if necessary		
Power legrests (if installed)	Check cable	Replace cable if necessary		
	Check contacts			
	Check functions			

Component	Check	Remedy	Notes	✓
Lighting (if installed)	Check cable	Replace lamp or cable if necessary	See 6.11 <i>Lighting Unit</i> , page 50.	
	Check function			
Battery mounting	Check battery support and mounting belts for damage	Replace if necessary		
Batteries	Check batteries for damage	Replace batteries if necessary	See 6.10.4 <i>Removing Batteries</i> , page 47 and 6.10.2 <i>Handling Damaged Batteries Correctly</i> , page 46.	
	Check battery voltage	Charge batteries	See user manual.	
	Check contacts and terminals	Clean contacts and terminals	See safety information under 6.10.4 <i>Removing Batteries</i> , page 47 and 6.10.2 <i>Handling Damaged Batteries Correctly</i> , page 46.	
Remote / electronics modules	Remote, status display blinking	Evaluate error/blink code	See corresponding remote and controls manual.	
	Fixings	Tighten fixings, replace if necessary		
	Cables and connecting plugs	Tighten cables and connecting plugs, replace if necessary		
	Joystick function	Replace joystick knob if necessary		
		Replace remote if necessary		
Power supply	Tighten cables and connecting plugs, replace if necessary			
Drive program	Check drive electronics program version	Update software if newer version available	See 6.9.8 <i>Updating Software</i> , page 45.	
Screws	Check screws for tight fit	Tighten screws if necessary		

## 6.6 Shrouds

### 6.6.1 Replacing Rear Shroud

#### Removing Rear Shroud

1. Loosen and remove two knurled thumb screws (1) on left and right side of rear shroud.
2. Carefully raise rear shroud.
3. Front part of shroud is held at top by hook-and-loop strip.
4. You must also release this.

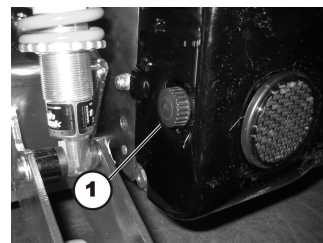

Fig. 6-2

#### Installing Rear Shroud

1. Install parts in reverse order.
2. Tighten knurled thumb screws finger-tight.

### 6.6.2 Replacing Centre Shroud



- 4 mm Allen key

### Removing Centre Shroud

1. Remove rear shroud. See 6.6.1 Replacing Rear Shroud, page 21.
2. If possible, use lifter to move seat to uppermost position.
3. Loosen two screws (A).
4. Lift rear part of shroud carefully and remove two spacers underneath shroud.
5. Lift off shroud. If mobility device does not have lifter, shroud must be bent apart carefully as shown in picture.

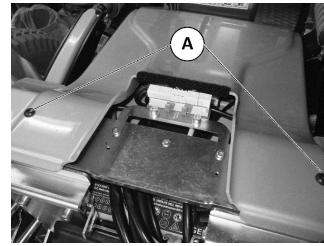

Fig. 6-3

### Installing Centre Shroud

1. Install parts in reverse order.
2. Tighten screws finger-tight.

## 6.6.3 Replacing Front Shroud



- 4 mm Allen key

### Removing Front Shroud

1. Use lifter to move seat to uppermost position. If no lifter is installed, remove seat as described in or Seating.
2. Remove rear and centre shroud. See 6.6.1 Replacing Rear Shroud, page 21 and 6.6.2 Replacing Centre Shroud, page 21.
3. Loosen two screws (1) – concealed by motor in picture.
4. Pull motor cable and guide bushes (2) out of lateral recesses.
5. Pull connecting cable to seat out of recess (3).
6. Lift front shroud up so that retaining clips (4) are exposed.
7. Pull shroud off towards front.

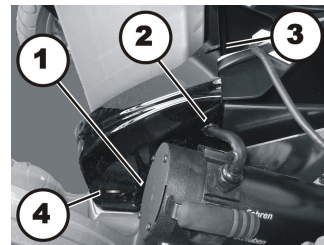

Fig. 6-4

### Installing Front Shroud

1. Install parts in reverse order.
2. Make sure that retaining clips (4) snap securely into openings of shroud.
3. Tighten all screws finger-tight.

## 6.6.4 Replacing Rear Light Shroud



- 4 mm Allen key
- 13 mm socket wrench

### Removing Rear Light Shroud

1. Remove rear and centre shroud. See 6.6 Shrouds, page 21.
2. Loosen nut (1) using a 13 mm socket wrench.

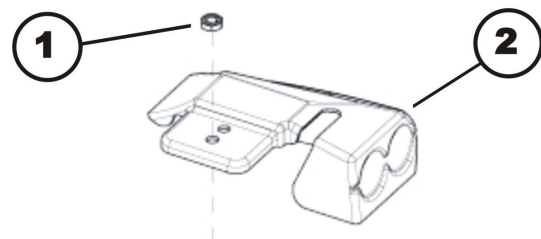

Fig. 6-5

### Installing Rear Light Shroud

1. Install parts in reverse order.
2. Tighten screws finger-tight.

## 6.6.5 Replacing Fender



- 5 mm Allen key

### Removing Fender

1. If possible, move seat to uppermost position.
2. Loosen and remove screws (F) and washers (E).
3. Remove fender (A) from adapter (C).
4. Loosen and remove screws (D).
5. Remove adapter (C) from transmission unit (B).

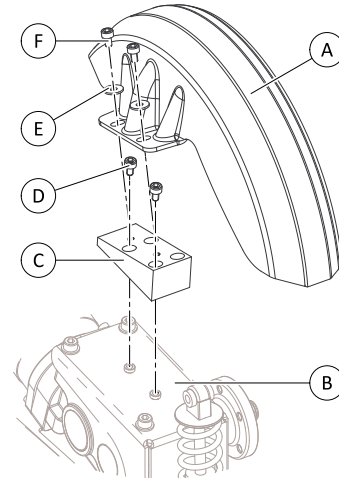

Fig. 6-6

### Installing Fender

1. Install parts in reverse order.
2. Test all functions.

## 6.7 Drive Components

### 6.7.1 Replacing Drive Unit



#### CAUTION!

#### Risk of crushing

Mobility device is very heavy. Risk of injury to hands and feet.

- Use proper lifting techniques. Risk of injury caused by uncontrolled movement of mobility device.
- Switch power supply off (ON/OFF key).
- Engage drive.
- Before raising mobility device, secure wheels by blocking them with wedges.



#### CAUTION!

#### Risk of crushing

The drive unit is very heavy. Risk of injury to hands and feet.

- Use proper lifting techniques.



- 5 mm Allen key
- 6 mm Allen key
- 13 mm wrench
- Oblong wooden blocks (at least 14 x 14 x 30 cm)

## Removing Drive Unit

1. Make power module accessible. See 6.9.2 *Making Power Module Accessible*, page 42.
2. Pull motor plug out of power module. Plugs differ according to controls system.
3. Remove centre shroud. See 6.6.2 *Replacing Centre Shroud*, page 21.
4. Open the cable clamps and expose motor cable.
5. Remove drive wheel and drive wheel hub. See 6.8.6 *Replacing Drive Wheel (5-Screw Installation)*, page 34 and 6.8.9 *Replacing Drive Wheel Hub*, page 41.
6. Remove fender. See 6.6.5 *Replacing Fender*, page 23.
7. Remove spring of shock absorber from upper fixation. See 6.7.5 *Replacing Suspension Strut*, page 28.
8. Loosen and remove screws (A) and washers (B).
9. Hold in place bolt (C). Loosen and remove nut (F) including washer (E).
10. Remove bolt (C) including washer (D).
11. Pull drive unit (H) out of mounting (G) in a forward direction. In doing so, observe high weight of unit.

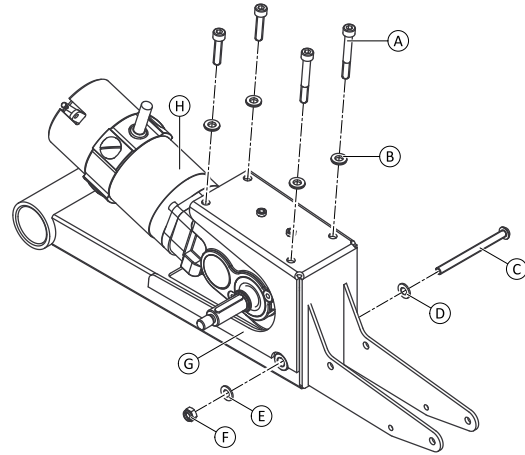



Fig. 6-7

## Installing Drive Unit

Before installing a new drive unit, check whether it should be installed to left-hand (LH) or right-hand (RH) side of mobility device. The drive units are different.

 Note labelling on motor plug.

1. Install parts in reverse order.
2. Connect motor cable to power module. Make sure that motor cable cannot be pinched or bent, and that it is not exposed to chafing in any place.
3. If LiNX system is used, perform calibration process. See *Suggested programming procedure* in LiNX service manual.
4. Test all functions.

## 6.7.2 Replacing Carbon Brushes

 This chapter refers to Storm<sup>4</sup>, Storm<sup>4</sup> X-plore and Storm<sup>4</sup> Max.

 Always replace all carbon brushes on both motors.

 DuraWatt motors are service-free, due to lifetime brushes.



### CAUTION!

#### Risk of crushing

Mobility device is very heavy. Risk of injury to hands and feet.  
– Use proper lifting techniques.





- 5 mm Allen key
- 6 mm Allen key
- 10 mm wrench (SSD motors only)
- 19 mm wrench
- Flat screwdriver (large)
- Oblong wooden blocks (at least 14 x 14 x 30 cm)

## Removing Carbon Brushes

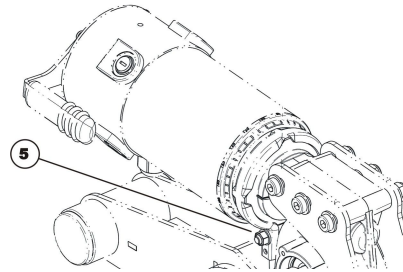

Fig. 6-8



SSD motors allow you to access the rear carbon brushes more easily by turning the motor around after loosening nut (5).

Make sure to turn the motor back into its original position after replacing the carbon brushes!

1. Switch OFF mobility device.
2. Remove drive wheel. See 6.8.6 *Replacing Drive Wheel (5-Screw Installation)*, page 34.
3. Disengage motor.
4. Loosen and remove all plastic caps (3).
- 5.



To guarantee optimum contact to the collector used carbon brushes need to be refitted exactly in same position from which they were taken.

Make marking on motor and carbon brushes to guarantee correct re-installing.

6. Remove carbon brushes completely from mounting (2).
7. Check carbon brush and spring for level of wear, broken components or discolouration.

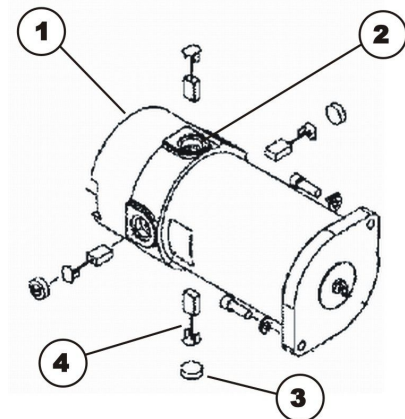

Fig. 6-9

## Installing Carbon Brushes

1. Depending on condition of brush and spring:
  - either replace brushes in exactly the same position from which they were taken or
  - fit new brushes.
2. Refit plastic caps and tighten firmly.
3. If necessary, turn motor into original position and tighten nut (5) fingertight.
4. Install drive wheels. See 6.8.6 *Replacing Drive Wheel (5-Screw Installation)*, page 34.
5. Run in new carbon brushes.

## Run In New Carbon Brushes



The following procedure is necessary to run carbon brushes in after replacement and thus guarantee maximum performance.



### CAUTION!

#### Risk of accidents

- Risk to workers, surroundings and mobility device.
- Do not leave mobility device unattended during following procedure.
  - Secure area.

1. Lift mobility device on one side and place a 14 cm high wooden block underneath it so that drive wheel is off ground and can rotate freely. Use proper lifting techniques.
2. Repeat this on other side of mobility device.
3. Run motors for an hour in forward direction.
4. Allow motors to cool down for 30 minutes.
5. Run motors for an hour in reverse direction.
6. Lift mobility device off wooden blocks.

### 6.7.3 Replacing Bowden Cables and Clutch



**CAUTION!**

**Risk of injury due to uncontrolled movement of mobility device**

Risk of injury caused by uncontrolled movement of the mobility device.

- Use proper lifting techniques.
- Turn power off.
- Engage motors.
- Secure mobility device against rolling away by placing wedges under wheels.



- 6 mm Allen key
- 13 mm wrench
- Phillips screwdriver, size 2
- Oblong wooden blocks (approx. 14 x 14 x 30 cm)

#### Removing Bowden Cables

1. Loosen the locking nuts (1) of the bowden cables on the clutch lever.
2. Loosen the adjustment nuts (2) of the bowden cables on the clutch lever.
3. Pull the bowden cables out of the lever unit.



Fig. 6-10

4. Loosen the screw of the pull-out protection (1).
5. Remove the pull-out protection from the bowden cable.
6. Loosen the locking nut (2) of the bowden cable on the motor.
7. Loosen the adjustment nut (3) of the bowden cable on the motor.
8. Pull the bowden cable out of its holder on the motor.
9. Repeat the procedure on the other motor.

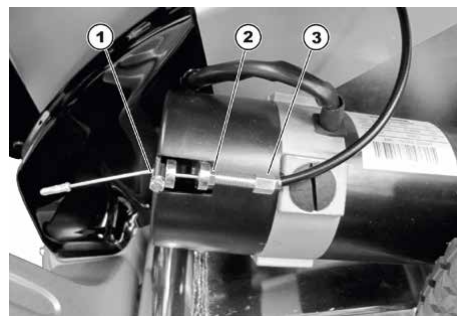

Fig. 6-11

### Removing Lever Unit

1. Loosen screw of clutch lever.
2. Remove clutch lever.
3. Loosen and remove four screws ⑥ and washers ③ of lever unit ⑤.
4. Remove lever unit ⑤ from fixation bracket ②.

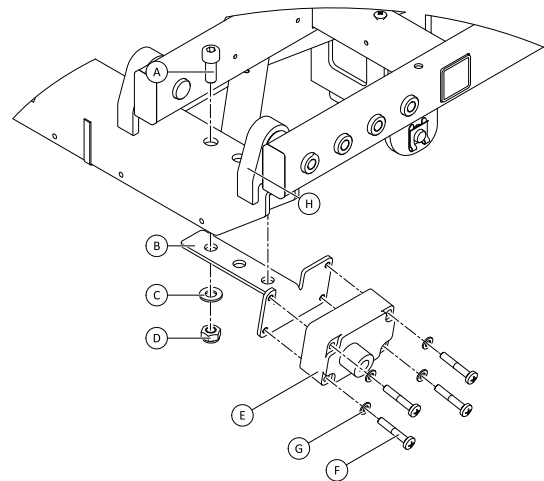

Fig. 6-12

### Removing Fixation Bracket of Lever Unit

1. Remove lever unit.
2. Loosen and remove screws including washers and nut ④ underneath seat frame. Screw ① is screwed into nut ④. The other screw is screwed into one of retaining sheets ②.
3. Pull fixation bracket ③ out of seat frame.

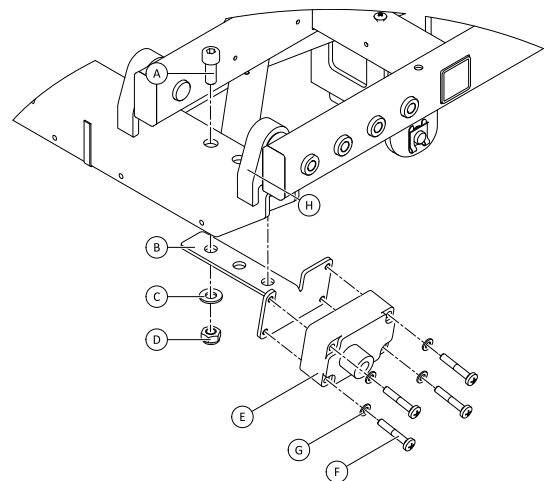

Fig. 6-13

### Installing Components

1. Replace defective components.
2. Install parts in reverse order.
3. Adjust clutch by loosening counter nut (1) and turning the adjustment nuts (2) on lever unit.
4. Test all functions.



Fig. 6-14

## 6.7.4 Replacing Motor Swing Arm

This chapter refers to Storm<sup>4</sup>, Storm<sup>4</sup> X-plore and Storm<sup>4</sup> Max.



#### CAUTION!

**Risk of Crushing to Hands and Feet by Weight of Mobility Device**

- Pay attention to hand and feet.
- Use proper lifting techniques.

**CAUTION!****Risk of Uncontrolled Movement of Mobility Device**

- Turn off power supply (ON/OFF key).
- Engage drive.
- Before raising mobility device, secure wheels by blocking them with wedges.
- Prevent the mobility device tipping by propping it up on a wooden block which is long and wide enough under the battery case. If the wooden block is too short or too high, the mobility device can still tip.



- 5 mm Allen key
- 6 mm Allen key
- TX40 Torx key
- 13 mm wrench
- 19 mm wrench
- Flat screwdriver
- Oblong wooden blocks (at least 14 x 14 x 30 cm)

**Removing Motor Swing Arm**

1. Remove drive wheel. See *6.8.6 Replacing Drive Wheel (5-Screw Installation)*, page 34.
2. Remove motor-gearbox unit. See *Replacing Motor-Gearbox Unit*, *Replacing Motor-Gearbox Unit (Storm<sup>4</sup> X-plore)* or *6.7.1 Replacing Drive Unit*, page 23 (*Storm<sup>4</sup> Max*).
3. Loosen and remove nut (1).
4. Remove washer (9).
5. Remove bolt (6). Pay attention to washer (7) and spacer (8).
6. Remove plastic cap (4).
7. Loosen and remove screw (3) including washer (2).
8. Remove motor swing arm (5) from axle.

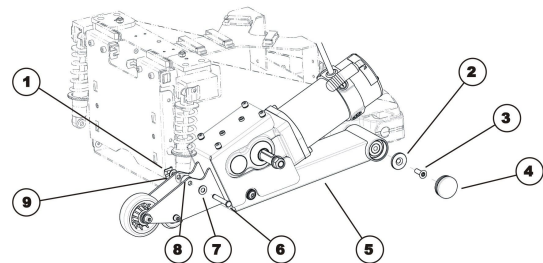

Fig. 6-15

**Installing Motor Swing Arm**

1. Install parts in reverse order.
2. Test all functions.

**6.7.5 Replacing Suspension Strut**

Invacare always recommends replacing both suspension struts to make sure that mobility device works perfectly.

**CAUTION!****Risk of crushing**

- Mobility device is very heavy. Risk of injury to hands and feet.
- Use proper lifting techniques.

**CAUTION!****Risk of crushing**

- Risk of injury caused by uncontrolled movement of mobility device.
- Switch off power supply (ON/OFF key).
  - Engage drive.
  - Before raising mobility device, secure wheels by blocking them with wedges.



- 6 mm Allen key
- 13 mm wrench
- Flat screwdriver
- Oblong wooden blocks (at least 14 x 14 x 30 cm)

## Removing Suspension Strut

1. Remove rear and centre shroud. See 6.6.1 Replacing Rear Shroud, page 21 and 6.6.2 Replacing Centre Shroud, page 21.
2. Remove drive wheel. See 6.8.6 Replacing Drive Wheel (5-Screw Installation), page 34.
3. Loosen and remove nut (1).
4. Remove spacer (8).
5. Remove bolt (5). Pay attention to washers (7) and spacers (6).
6. Remove SL retainer clip on upper fixation.
7. Remove pin (2). Pay attention to washers.
8. Remove suspension strut.

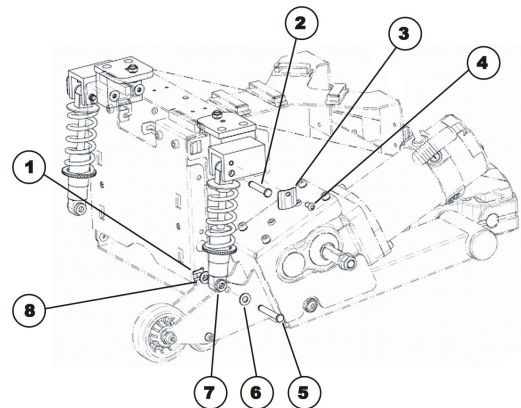

Fig. 6-16 Example of a Storm<sup>4</sup> motor swing arm including suspension strut. Suspension strut of Storm<sup>4</sup> Max can marginally differ from this illustration.

## Installing Suspension Strut

1. Install parts in reverse order.
2. Test all functions.

## 6.7.6 Replacing Front Swing Arm



### CAUTION!

#### Risk of crushing

Mobility device is very heavy. Risk of injury to hands and feet.

- Use proper lifting techniques. Risk of injury caused by uncontrolled movement of mobility device.
- Switch off power supply (ON/OFF key).
- Engage drive.
- Before raising mobility device, secure wheels by blocking them with wedges.



- 5 mm Allen key
- 17 mm Allen key
- Flat screwdriver
- 25 Nm torque wrench
- 200 Nm torque wrench
- Oblong wooden blocks (at least 14 x 14 x 30 cm)

## Removing Front Swing Arm

1. Prop up mobility device, using several wooden blocks. Use proper lifting techniques.
2. Use screwdriver to remove plastic cap (5).
3. Loosen and remove Allen screw (4) with 17 mm Allen key.
4. Remove two Nord-Lock lock washers (3).
5. Remove and replace front swing arm (2).

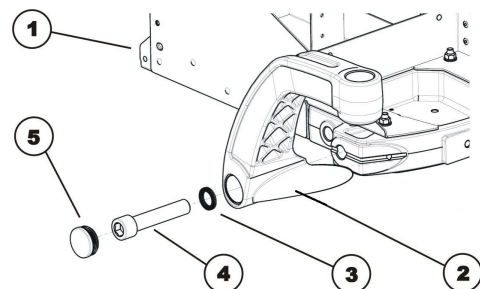

Fig. 6-17

## Installing Front Swing Arm

1. Install parts in reverse order.
2. Tighten Allen screw (4) to 200 -180 Nm.
3. Test all functions.

### 6.7.7 Replacing Castor Fork

**CAUTION!**
**Risk of injury due to uncontrolled movement of mobility device**

- Use proper lifting techniques. Risk of injury caused by uncontrolled movement of the mobility device.
- Turn power off.
- Engage motors.
- Secure mobility device against rolling away by placing wedges under wheels.



- 19 mm socket wrench
- Flat screwdriver (large)
- Oblong wooden blocks (at least 14 x 14 x 30 cm)

#### Removing Fork

1. Remove plastic cap (A).
2. Loosen and remove nut (B).
3. Pull fork (F) out of front swing arm (E) in a downward direction. Pay attention to curved spring washer (C), plain washer (D) and ball bearings (not shown in illustration).

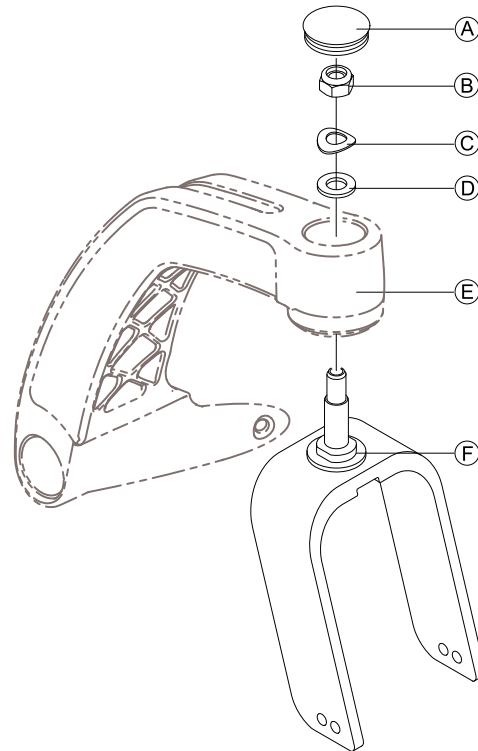

Fig. 6-18

#### Installing Fork

1. Install parts in reverse order. Make sure that wide inner ring faces outward in each case.
2. Adjust wheel fork. See 6.7.8 *Adjusting Castor Fork*, page 30.
3. Test all functions.

### 6.7.8 Adjusting Castor Fork

**CAUTION!**
**Risk of crushing**

- Mobility device is very heavy. Risk of injury to hands and feet.
- Use proper lifting techniques.



- 19 mm socket wrench
- Blade screwdriver

1. Remove cover cap (2).
2. Tilt mobility device to rear. Use proper lifting techniques.
3. Rotate castor forks (5) upwards.
4. Let go of castor forks so that they can swing downwards again.
5. Adjust nut (3) so that castor forks are not too loose but can still rotate freely. The castor forks should reach opposite side once (maximum), then come to rest facing downwards.
6. Place mobility device on four wheels.
7. Test mobility device's manoeuvrability.
8. Repeat adjustment steps if necessary until castors are correctly adjusted.
9. Refit cap (2).

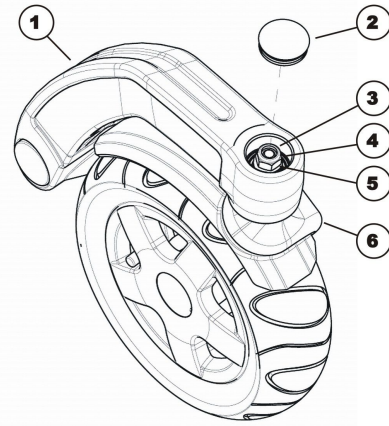

Fig. 6-19

## 6.8 Wheels

### 6.8.1 Repair Instructions



#### Important information about maintenance work tools!

- Some maintenance work which is described in this manual and can be carried out by the user without problems require the correct tools for proper work. If you do not have the correct tool available we do not recommend that you try to carry out the relevant work. In this case, we urgently recommend that you contact an authorised specialist workshop.

The following are instructions on maintenance and repairs that can be performed by the user. For the specifications of spare parts please see *Technical Data*, or consult the service manual, available from Invacare (in this connection please see the addresses and phone numbers at the end of this user manual). In case you require assistance, please contact your Invacare dealer.



#### CAUTION!

**Risk of damage or injury if the mobility device is accidentally set into motion during repairs**

- Switch the power off (ON/OFF Button).
- Engage the motors.
- Secure the mobility device against rolling away by placing wedges under the wheels.



#### CAUTION!

**Risk of hands and feet being crushed by the weight of the wheelchair**

- Pay attention to your hands and feet.
- Use the correct lifting techniques.

### 6.8.2 Tyre Pressure



#### CAUTION!

**Risk of damage to rim and tyre when tyre pressure is exceeded**

- Observe recommended tyre pressure.

For recommended tyre pressure see inscription on tyre, rim, or contact Invacare. Compare table below for conversion.

psi	bar
22	1.5
23	1.6
25	1.7
26	1.8
28	1.9
29	2.0
30	2.1
32	2.2
33	2.3

psi	bar
35	2.4
36	2.5
38	2.6
39	2.7
41	2.8
42	2.9
44	3.0

### 6.8.3 Tyre Types

There are three different types of tyres or inner tubes, and specific points must be observed for the replacement of each type. The individual types of tyres can be easily distinguished:

- Pneumatic tyres have black valve caps.
- Puncture-protected tyres have red valve caps.
- Puncture-proof tyres have no valves.









There are five chapters about tyre repair and wheel replacement:









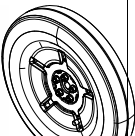

- *6.8.6 Replacing Drive Wheel (5-Screw Installation), page 34*
- *Replacing Drive Wheel (1-Bolt Installation)*
- *6.8.7 Replacing Castor Wheel on Double-Sided Fork, page 35*
- *Replacing Castor Wheels on Single-Sided Fork*
- *Replacing Tyres* deals with tube repair and replacing solid tyres.

 Not all chapters are necessarily contained in this manual.

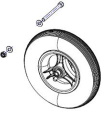
 Specific tightening torques for wheels and rim halves are listed in *6.8.4 Specific Tightening Torques, page 32*.

### 6.8.4 Specific Tightening Torques



	Drive Wheels								
	10" x 3"		12 1/2" x 2 1/4"			14"			
									
<b>Wheel Fixation</b>	70 Nm	70 Nm	33 Nm	35 Nm	70 Nm	33 Nm	60 Nm	25 Nm	18 Nm
<b>Rim Halves</b>	25 Nm	25 Nm	10 Nm	25 Nm	25 Nm	10 Nm	25 Nm	25 Nm	18 Nm

























	Castor Wheels									
	6"		8"			9"			10"	
										
<b>Wheel Fixation</b>	18 Nm	18 Nm	25 Nm	16 Nm	16 Nm	25 Nm	25 Nm	25 Nm	18 Nm	100 Nm
<b>Rim Halves</b>	10 Nm	25 Nm	5 Nm	—	—	—	25 Nm	5 Nm	25 Nm	25 Nm



### 6.8.5 Overview of Power Wheelchair Models and Wheel Types

- Not all wheel types are available for all power wheelchairs, see footnotes.
- The symbols indicate three tyre types:

		
pneumatic = black valve cap	puncture-protected = red valve cap	puncture-proof = no valve

Models	Drive wheels								
	10" x 3"	12 1/2" x 2 1/4"			14"				
									
4-Spoke Rim (1-Bolt Installation)	3-Spoke Rim (1-Bolt Installation)	5-Spoke Rim (1-Bolt Installation)	5-Spoke Plastic Rim (1-Bolt Installation)	3-Spoke Rim (1-Bolt Installation)	5-Spoke Rim (1-Bolt Installation)*	5-Spoke Rim (5-Screw Installation)	5-Spoke Rim for True Track*	Solid Rim (5-screw installation)	
TDX SP2									
Storm <sup>4</sup> Series									
Kite									
Bora									
Fox									
Stream									
Mirage									
Dragon									
Pronto M41									
AVIVA RX									

\* For wheelchair-specific mounting instruction, see respective manual.

Models	Castor Wheels									
	6"		8"				9"		10"	
	Single-Sided/ Double-Sided Fork	Double-Sided Fork				Single-Sided/ Double-Sided Fork	Double-Sided Fork	Single-Sided/ Double-Sided Fork	Double-Sided Fork	Single-Sided Fork
TDX SP2	■									
Storm <sup>4</sup> Series									□ ■ ■	□ ■ ■
Kite							* * □ ■		□ ■ ■	□ ■ ■
Bora		■		□ ■	■		□ ■			
Fox		■	■							
Stream							■			
Mirage		■	□ ■		■					
Dragon							■			
Pronto M41	■									
AVIV-A RX						■		□ ■ ■		

\* For wheelchair-specific mounting instruction, see respective manual.

### 6.8.6 Replacing Drive Wheel (5-Screw Installation)

This chapter deals with drive wheels that are installed with four or five screws.



**CAUTION!**  
**Risk of Crushing to Hands and Feet by Weight of Mobility Device**

- Pay attention to hand and feet.
- Use proper lifting techniques.



**CAUTION!**  
**Risk of Uncontrolled Movement of Mobility Device**

- Turn off power supply (ON/OFF key).
- Engage drive.
- Before raising mobility device, secure wheels by blocking them with wedges.
- Prevent the mobility device tipping by propping it up on a wooden block which is long and wide enough under the battery case. If the wooden block is too short or too high, the mobility device can still tip.



- 6 mm Allen key
- 13 mm wrench
- Torque wrench
- Oblong wooden block (at least 12 x 12 x 30 cm) for propping up mobility device

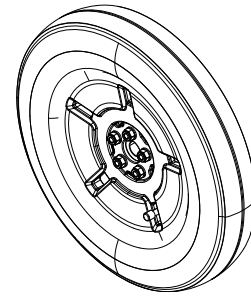

- Torx wrench with TX 40 bit
- Torque wrench
- Mounting kit
- Oblong wooden block (at least 12 x 12 x 30 cm) for propping up mobility device

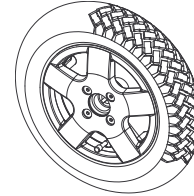

- 6 mm Allen key
- Torque wrench
- Oblong wooden block (at least 12 x 12 x 30 cm) for propping up mobility device
- Medium-strength thread locking adhesive (Loctite 243 or similar)



When removing, take care of small parts such as screws and washers. Put all small parts down so that they can be installed in correct sequence.

1. Remove legrests.
2. Place wooden block under frame to prevent mobility device from rolling away.
3. Loosen and remove screws which secure wheel.
4. Remove wheel from hub.
- 5.



#### CAUTION!

#### Risk of Injury if Wheels Come Off

If drive wheels are insufficiently tightened during assembly, they can come off during driving.

- Always use new screws with undamaged coating.
- Tighten screws to prescribed torque when mounting drive wheels.

Install parts in reverse order.

6. When installing wheel, pay attention to correct direction of rotation.

### 6.8.7 Replacing Castor Wheel on Double-Sided Fork



- 5 mm Allen key
- 13 mm wrench
- Oblong wooden block (at least 14 x 14 x 30 cm)



- 13 mm wrench (2x)
- Oblong wooden block (at least 14 x 14 x 30 cm)



- 6 mm Allen key
- 13 mm wrench
- Oblong wooden block (at least 14 x 14 x 30 cm)





- 6 mm Allen key
- 13 mm wrench
- Oblong wooden block (at least 14 x 14 x 30 cm)



- 5 mm Allen key
- Oblong wooden block (at least 14 x 14 x 30 cm)



- 5 mm Allen key
- 13 mm wrench
- Oblong wooden block (at least 14 x 14 x 30 cm)



### Removing Wheel

1. Place wooden block underneath mobility device and prop up mobility device.
2. Remove end-caps from bolt and nut (if applicable).
- 3.

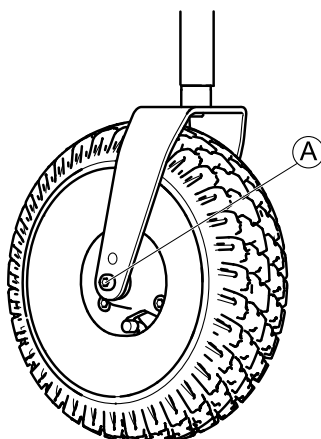

Fig. 6-20

Remove nut from bolt (A).

4. Remove bolt and wheel from fork.

### Installing Wheel

1. Install parts in reverse order.
2. When installing wheel, pay attention to correct direction of rotation.
3. Tighten nut to prescribed torque. See 6.8.4 *Specific Tightening Torques*, page 32.

### Replacing Castor Wheel (Aviva RX and Storm<sup>4</sup> Max)



- 5 mm Allen key (up to August 2016)
- TX40 Torx key (starting August 2016)
- Oblong wooden block (at least 14 x 14 x 30 cm)

## Removing Wheel

1. Loosen and remove bolts (A).
- 2.

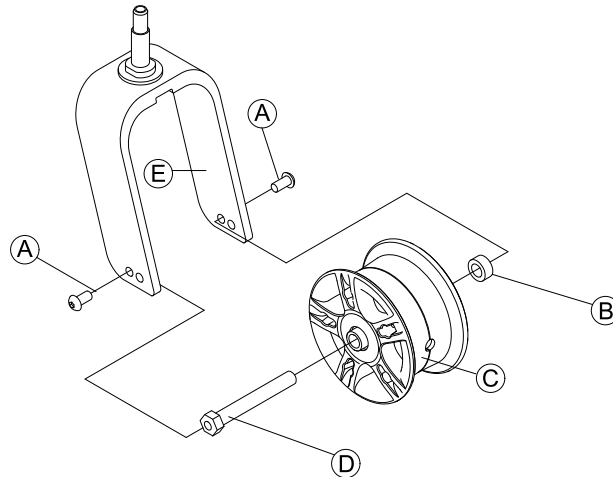

Fig. 6-21

Pull wheel (C) including axle (D) and bushing (B) out of fork (E).

## Installing Wheel



### CAUTION!

#### Risk of injury from wheels coming loose

If wheels are insufficiently secured during mounting, it can come loose when driving.

- When mounting wheels tighten bolts with prescribed torque.
- Secure all bolts using a suitable blocker.
- Never use normal nuts instead of self-locking nuts.
- Always use new nuts and bolts with an undamaged coating.

1. Install parts in reverse order. Pay attention to correct direction of rotation when installing wheels.
2. Test all functions.

## Replacing Castor Wheel (6 inch wheel)



- 2 x 7/16 inch wrench
- Oblong wooden block (at least 14 x 14 x 30 cm)



## Removing Wheel

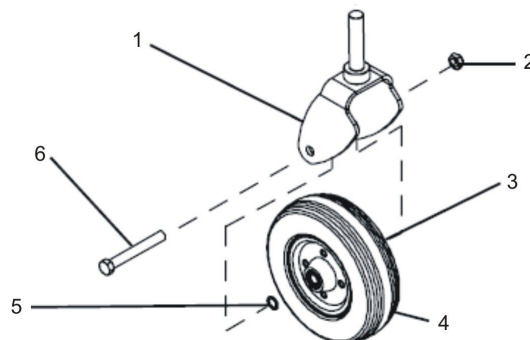

Fig. 6-22

1. Loosen nut (2).
2. Remove screw (6).
3. Remove two washers (3) and (5).
4. Remove wheel (4).
5. Replace any defective parts.

## Installing Wheel

1. Install parts in reverse order.
2. When installing wheel, pay attention to correct direction of rotation.
3. Tighten nut to prescribed torque. See 6.8.4 *Specific Tightening Torques*, page 32.

## 6.8.8 Replacing Flat Castor Tyre / Inner Tube



- 5 mm Allen key
- Torque wrench 5 Nm — 25 Nm (or similar)
- Three joiner's clamps with plastic caps (puncture-proof tyres only)
- Two long wooden blocks (min. 14 x 14 x 30 cm)
- Repair kit for inner tube tyres or a new inner tube
- Tyre pump or compressor
- Talcum powder or tyre lubrication



There are three different types of tyres or inner tubes, and specific points must be observed for replacement of each type. The individual types of tyres can be easily distinguished:

- Pneumatic tyres have black valve caps.
- Puncture-protected tyres have red valve caps.
- Puncture-proof tyres have no valves.

Proceed in accordance with the appropriate chapter:

- Replacing pneumatic tyres – see *Installing Tyres, page 38*
- Replacing puncture-protected tyres – see *Installing Tyres, page 39*
- Replacing puncture-proof tyres – see *Installing Tyres, page 40*

### Replacing Pneumatic Tyres



Pneumatic tyres have black valve caps.

### Removing Tyres



#### CAUTION! Risk of explosion

There is considerable pressure in the tyre. Risk of injury. Parts can be thrown out and injure you if you do not deflate all air from tyre.

– Press release pin in valve inwards and deflate all air from tyre.

1. Remove valve cap (B).
2. Press release pin in valve inwards and deflate all air from tyre.
3. Loosen and remove screws (F) on inside of wheel.
4. Release inner (D) and outer rim rings (E) from tyre (A).
5. Remove inner tube (C) from tyre (A).
6. Replace defective or worn parts or repair parts.

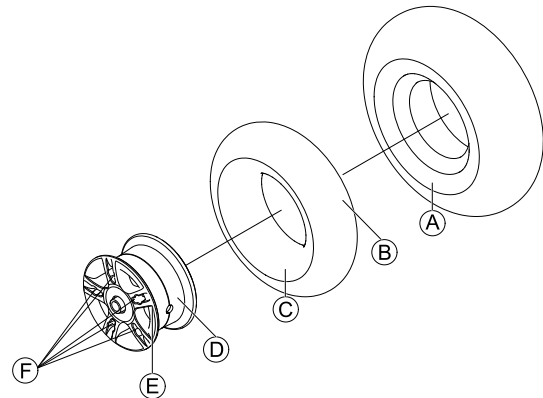



Fig. 6-23 Example of Storm<sup>4</sup> MAX castor wheel. Valve and valve cap (B) are not shown in illustration.

7. Remove wheel from fork.

## Installing Tyres

1. Install inner tube in tyre.

 If the old inner tube is to be repaired and used again and has become wet during repair, installation can be made easier by applying some talcum powder to inner tube.

2. Install rim rings  $\textcircled{D}$  and  $\textcircled{E}$  to tyre. Make sure that boreholes and thread for screws are exactly on top of each other.
3. Fill some air into inner tube.
4. Install screws on inside of wheel and tighten.
5. Check exact fit of tyre on rim.
6. Inflate tyre to prescribed air pressure.
7. Re-check exact fit of tyre on the rim.
8. Screw valve cap back on.
9. Install wheel.

## Replacing Puncture-Protected Tyres

 Puncture-protected tyres have red valve caps.

## Removing Tyres



### CAUTION! Risk of explosion

There is considerable pressure in the tyre. Risk of injury. Parts can be thrown out and injure you if you do not deflate all air from tyre.

– Press release pin in valve inwards and deflate all air from tyre.



### CAUTION! Risk of damage

Valve can become blocked by puncture protection gel and become unusable.

– During following steps you should always hold valve up so that puncture protection gel cannot enter valve.

1. Remove wheel from fork.
2. Remove valve cap  $\textcircled{B}$ .
3. Press release pin in valve inwards and deflate all air from tyre.
4. Loosen and remove screws  $\textcircled{F}$  on inside of wheel.
5. Release inner  $\textcircled{D}$  and outer rim ring  $\textcircled{E}$  from tyre  $\textcircled{A}$ .
6. Remove inner tube  $\textcircled{C}$  from tyre  $\textcircled{A}$ .
7. Replace defective or worn parts or repair parts.

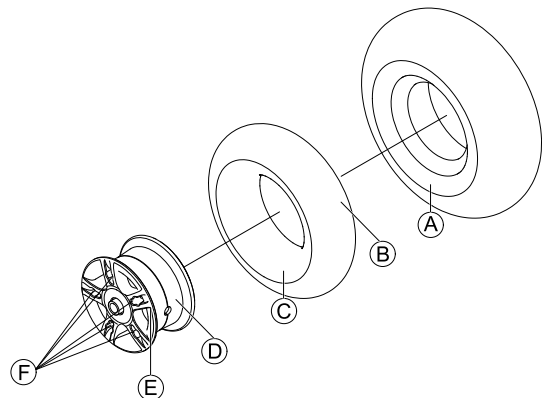



Fig. 6-24 Example of Storm<sup>4</sup> MAX castor wheel. Valve and valve cap  $\textcircled{B}$  are not shown in illustration.

## Installing Tyres

1. Install inner tube in tyre.

 If the old inner tube is to be repaired and used again and has become wet during repair, installation can be made easier by applying some talcum powder to inner tube.

2. Install rim rings ④ and ⑤ to tyre. Make sure that boreholes and thread for screws are exactly on top of each other.
3. Fill some air into inner tube.
4. Install screws on inside of wheel and tighten.
5. Check exact fit of tyre on rim.
6. Inflate tyre to prescribed air pressure.
7. Re-check exact fit of tyre on the rim.
8. Screw valve cap back on.
9. Install wheel.

## Replacing Puncture-Proof Tyres

 Puncture-proof tyres have no valves.

## Removing Tyres



### **WARNING!** **Risk of explosion**

There is considerable pressure in tyre. Risk of injury! Parts can be thrown out and injure you if you do not secure rim rings.

– Secure rim rings with joiner's clamps.

1. Remove wheel from fork.
2. Secure rim rings against unexpected discharge with three joiner's clamps. Make sure you do not to scratch rims.
3. Loosen and remove five screws ⑥ on inside of wheel.
4. Loosen joiner's clamps carefully and alternately until rim rings can be removed without danger.
5. Remove inner ④ and outer ⑤ ring of rim from tyre ①.
6. Replace any defective or worn parts.

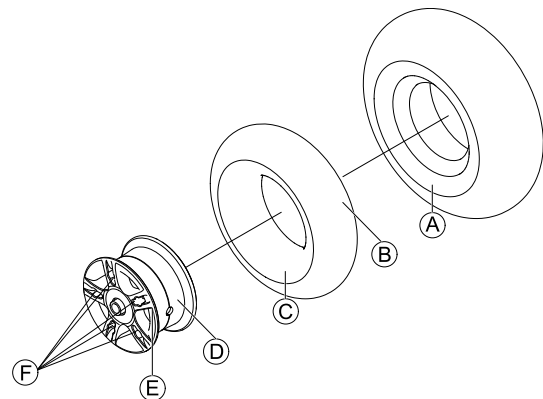

Fig. 6-25 Example of Storm<sup>4</sup> MAX castor wheel. Valve and valve cap ② are not shown in illustration.

## Installing Tyres

1. Install tyres to rim in reverse order.
2. Install rim rings ④ and ⑤ to tyre. Make sure that boreholes and thread for screws are exactly on top of each other.
3. Place joiner's clamps in position.
4. Tighten joiner's clamps alternately in small stages until rim rings are precisely aligned.
5. Install screws on inside and tighten screws ⑥ to 18 Nm.
6. Install wheel.



## 6.8.9 Replacing Drive Wheel Hub



### CAUTION!

#### Risk of damage to mobility device

Collisions can be caused if adjusting washers are removed during fitting work to drive wheels. Adjusting washers are often fitted between drive shaft and wheel hub to even out tolerances. If adjusting washers are removed and not replaced again, collisions can be caused.

– Always replace adjusting washers exactly as they were before you started dismantling.



- 19 mm socket wrench

### Removing Drive Wheel Hub

1. Loosen and remove nut (3).
2. Remove washer (2).
3. Remove wheel hub (1) from axle (4).
4. Remove feather key (5) from axle.

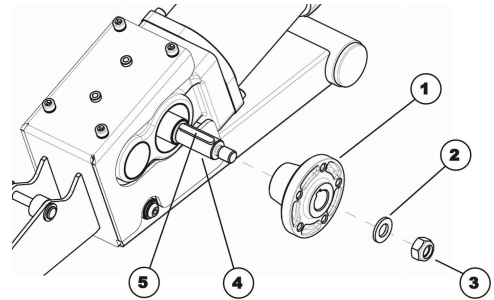

Fig. 6-26

### Installing Drive Wheel Hub

1. Install drive wheel hub parts in reverse order.
2. Use thin film of lubricant to make pushing wheel hub onto axle easier.
3. Test all functions.

## 6.8.10 Replacing Big Anti-Tipping Wheel



Mark current settings of wheel, shim rings and spacer before dismantling.



- 6 mm Allen key
- 13 mm wrench

1. Remove end cap (A).
2. Loosen and remove nut (B) including washer (C).
3. Remove bolt (F). Pay attention to spacer (D), shim rings (H) and wheel (E).
4. Install parts in reverse order.
5. Test all functions.

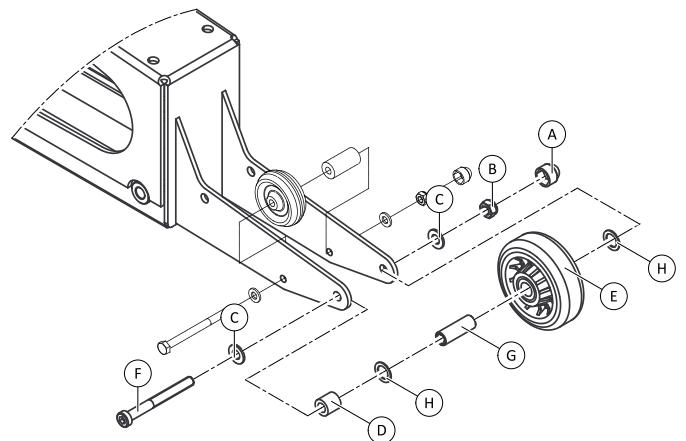

Fig. 6-27

## 6.8.11 Replacing Small Anti-Tipping Wheel



Mark current settings of wheel and spacer before dismantling.



- 10 mm wrench (2x)

1. Remove end cap (A).
2. Loosen and remove nut (B) including washer (C).
3. Remove bolt (F). Pay attention to spacer (D) and wheel (E).
4. Install new parts in reverse order.
5. Test all functions.

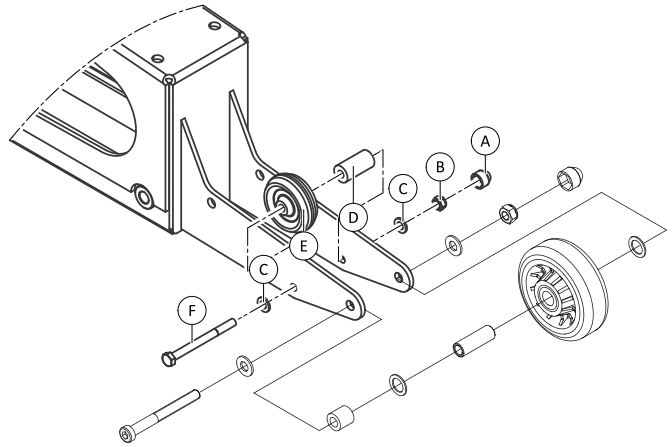



Fig. 6-28

## 6.9 Controls

### 6.9.1 Replacing remote

 Replacing remote is very easy and is not described in detail. However, when replacing a remote in connection with power module, take into account the final selection of drive program. See 6.9.7 Drive Program Selection After Component Replacement, page 45.

### 6.9.2 Making Power Module Accessible

1. If possible, completely raise seat with lifter.
2. Switch OFF electronics of mobility device.
3. Remove rear shroud. See 6.6.1 Replacing Rear Shroud, page 21.
4. Press both catches (3) inwards and open battery box shroud.

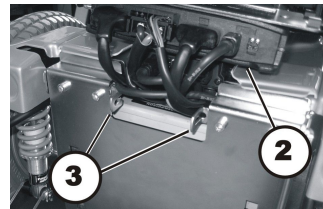

Fig. 6-29

5. Take note of the positions of all cables and the sockets that they are connected to. Mark the connectors and sockets or take a photograph.
6. Remove all plugs (A) from power module.

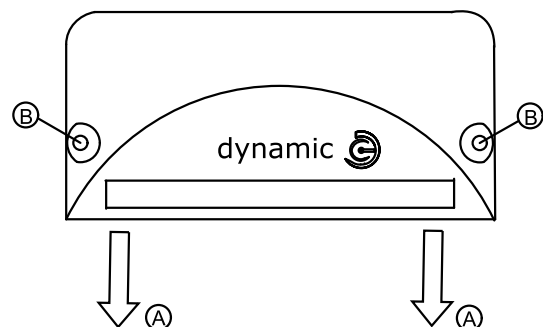

Fig. 6-30

### 6.9.3 Replacing Power Module

The various power modules can be installed to the mobility device with a range of different remotes. Power modules are described in corresponding controls manuals or earlier revisions of this manual. Replacement is described below using LiNX power module as an example. The course of action is the same for other power modules. The only difference is the terminal layout.

**CAUTION!**

Any changes to the drive program can affect the driving characteristics and the tipping stability of the mobility device

- Changes to the drive program may only be carried out by trained providers.
- Invacare can only give a warranty for safe mobility device driving behaviour - especially the tipping stability - for unaltered standard drive programs.



All power modules are delivered with a standard drive program. If you have carried out customer-specific modifications to the drive program, you will have to make these changes again after installing new power module.

### Removing Power Module



- 4 mm Allen key
- To adapt the drive program: Programming software or hand programming device and system installation manual, available from Invacare.

1. Making power module accessible. See 6.9.2 *Making Power Module Accessible*, page 42.
2. Loosen and remove screws (B) on both sides of power module. Pay attention to small parts, such as washers and spacers.
3. Remove power module.

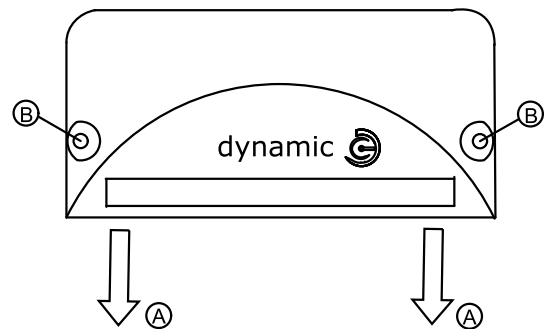

Fig. 6-31

### Installing Power Module



For details on cable routing and information about Updating drive program and Adapting drive program, see LiNX Service Manual.

1. Install parts in reverse order. Pay attention to place lock washers between bracket and power module, if available.
2. If LiNX system is used, perform calibration process. See *Suggested programming procedure* in LiNX service manual.
3. If available, update drive program.
4. If necessary, adapt drive program to user's need.
5. Test all functions.

### 6.9.4 Replacing G-Trac Sensor



- 5 mm Allen key
- 10 mm wrench

1. Make power module accessible. See 6.9.2 *Making Power Module Accessible*, page 42.
2. Loosen and remove screw (A) and washer (B).
- 3.



Sensor must be installed with cable pointing upwards. Sensor has a guide at backside that must fit exactly into corresponding hole on bracket (D).

Replace G-Trac sensor (C).

4. Insert washer (B) and screw (A) and tighten screw.
5. Test all functions.

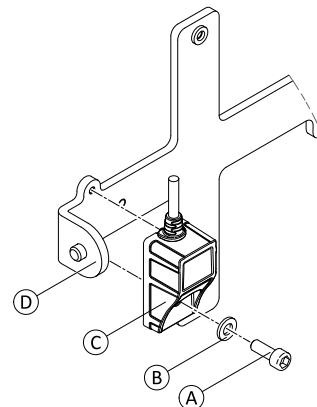



Fig. 6-32 Example of G-Trac sensor on LiNX system (power module not shown).

## 6.9.5 Replacing Actuator Module

-  LiNX systems do not require an actuator module. Powered tilt and -recline are controlled directly by the power module.

The actuator module is optional.

Depending on the amount of the installed actuators, such as powered tilt or -recline, different module types can be installed on the mobility device.

Amount of actuators	Module type	Location
up to 2	ACT2	Chassis, next to lighting PCB
3 and 4	ACT4	Under seat, right-hand side of seat support.

-  • 4 mm Allen key

### Removing ACT2

1. Remove rear and centre shroud. See 6.6.1 *Replacing Rear Shroud, page 21* and 6.6.2 *Replacing Centre Shroud, page 21*.
2. Carefully note the location of the cable and the connection locations of the various plugs. Either mark each plug and socket, or take a photograph with a digital camera.
3. Unplug all plugs **(B)** from module **(A)**.
4. Loosen and remove screws **(C)**.
5. Replace module.

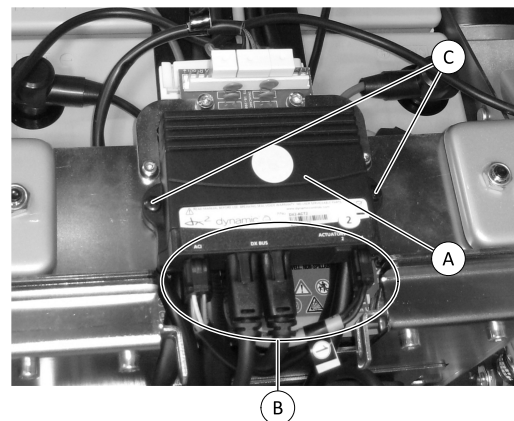

Fig. 6-33

### Removing ACT4

1. Remove seat. See 6.12.1 *Replacing Seat Frame, page 53*.
2. Carefully note the location of the cable and the connection locations of the various plugs. Either mark each plug and socket, or take a photograph with a digital camera.
3. Unplug all plugs from module **(A)**.
4. Loosen and remove screws.
5. Replace module.

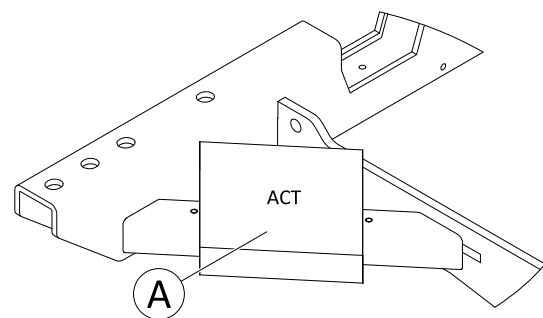



Fig. 6-34

### Installing Actuator Module

1. Install parts in reverse order.
2. Plug all plugs into their old positions.
3. Test all functions.

## 6.9.6 Replacing Light Board

Replacement is described in the following section based on the example of a mobility device with an optional light board and an optional actuator module.

-  • 4 mm Allen key  
 • 8 mm socket wrench

## Removing Light Board

1. If possible, use lifter to move seat to uppermost position.
2. Remove rear and centre shroud. See *6.6.1 Replacing Rear Shroud, page 21* and *6.6.2 Replacing Centre Shroud, page 21*.
3. Carefully note the location of the cable and the connection locations of the various plugs. Either mark each plug and socket, or take a photograph with a digital camera.
4. Pull plug **A** out of light board.
5. Loosen and remove two screws **C**.
6. Lift off light board together with retaining bracket.
7. Loosen screws **B** and the corresponding nuts on the rear.
8. Replace light board.

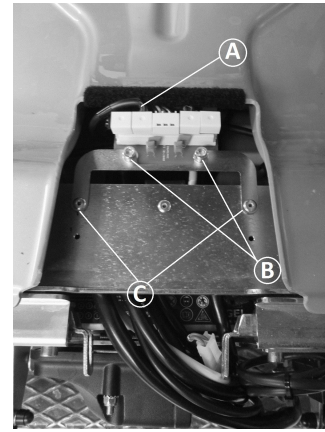



Fig. 6-35

## Installing Light Board

1. Install parts in reverse order.
2. Plug all plugs into their old positions.
3. Check all mobility device functions.

## 6.9.7 Drive Program Selection After Component Replacement

The drive program is saved in the remote, and also in the power module. If one of these two components is replaced, the system must be told which of the components has not been replaced so that it knows which contains the current controller profile.

 The system allows normal usage of the mobility device after component replacement only if the profile is selected afterwards.

 For details, see corresponding remote manual.

## 6.9.8 Updating Software

The drive programs for mobility devices are continually being further developed and improved by Invacare. For this reason, you should always check whether the drive program version number is up-to-date when carrying out any repairs or regular maintenance.

If a newer version is available, the drive program should be updated. The procedure for updating the drive program are described either in the Wizard software user manual or the LiNX service manual.



### WARNING!

**Any changes to drive program can affect driving characteristics and tipping stability of mobility device.**

- Changes to drive program may only be carried out by trained providers.
- Invacare can only give a warranty for safe mobility device driving behaviour — especially tipping stability — for unaltered standard drive programs.

## ACS2, Shark, R-Net, and VR2 Electronics



The power wheelchair is supplied with a standard drive program. If the drive program has been customised, you have to perform this customisation again, after installing the new drive program. This also applies to the customer-specific options of the seat setting for ACS2 remotes, which are activated ex works.



When a powered adjustment option is retrofitted, such as powered legrests, then this option needs to be activated in the driving program as well if you have an ACS2 remote. For more information, refer to the user manual of the Wizard software and the installation instructions for the electronic modules.



- Dynamic® Wizard software
- Wizard software user manual
- Further requirements, such as a minimum system configuration for the PC used for programming, required programming cables etc., can be taken from the Wizard software user manual.

## LiNX Electronics

Programming parameters and further information about updating can be taken from the LiNX service manual, available from Invacare.

### 6.10 Batteries



#### CAUTION!

##### **Injury hazard and possible material damages if batteries are handled improperly**

The installation of new batteries may only be carried out by authorised specialists.

- Observe the warning information on the batteries.
- Only use battery versions stated in the specifications.



#### CAUTION!

##### **Fire and burns hazard if battery terminal is bypassed**

– Take great care to ensure that the battery terminals are never short-circuited with tools or mechanical mobility device parts.

- Ensure that the battery terminal caps have been replaced if you are not working on the battery terminals.



#### CAUTION!

##### **Risk of crushing**

Batteries can be extremely heavy. This results in injury hazards to your hands.

- Handle the batteries with care.
- Ensure that batteries do not fall to the ground when removed from chassis.
- Pay attention to hands.
- Use proper lifting techniques.



#### WARNING!

##### **Burn hazard**

Injury hazard due to discharged acid.

- Always wear acid-proof protective gloves when handling batteries.
- Always wear protective goggles when handling batteries.

##### **What to do if acid is discharged**

- Always take clothing which has been soiled by or dipped in acid off immediately!
- Rinse any areas of your skin which has come into contact with battery acid off immediately with plenty of water!

##### **If contact with eyes is made**

- You should also consult an eye specialist immediately afterwards!



When removing, take care of small parts such as screws and washers. Put all small parts down so that they can be installed in correct sequence.

#### 6.10.1 General Instructions on Handling Batteries

- Never mix and match different battery manufactures or technologies, or use batteries that do not have similar date codes.
- Never mix gel with AGM batteries.
- The batteries reach their end of life when the drive range is significantly smaller than usual. Contact your provider or service technician for details.
- Always have your batteries installed by a properly trained mobility device technician or a person with adequate knowledge. They have the necessary training and tools to do the job safely and correctly.

#### 6.10.2 Handling Damaged Batteries Correctly



#### CAUTION!

##### **Corrosion and burns from acid leakage if batteries are damaged**

- Remove clothes that have been soiled by acid immediately.

##### **After contact with skin:**

- Immediately wash affected area with lots of water.

##### **After contact with eyes:**

- Immediately rinse eyes under running water for several minutes; consult a physician.

- Always wear safety goggles and appropriate safety clothing when handling damaged batteries.
- Place damaged batteries in an acid-resistant receptacle immediately after removing them.

- Only ever transport damaged batteries in an appropriate acid-resistant receptacle.
- Wash all objects that have come into contact with acid with lots of water.

### Disposing of Dead or Damaged Batteries Correctly

Dead or damaged batteries can be given back to your provider or directly to Invacare.

### 6.10.3 Making Batteries Accessible

Various power modules can be installed to the mobility device. Instructions below show Storm<sup>4</sup> Max and ACS 2 power module as example. The course of action is the same for other mobility devices.

1. Remove rear shroud. See 6.6.1 *Replacing Rear Shroud*, page 21.
2. Press both catches (3) inwards and open battery box shroud.

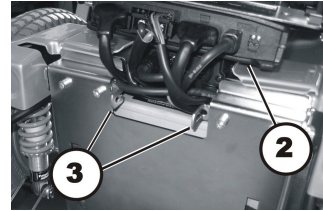

Fig. 6-36

3. Pull locking pin (A).
4. Place power module, together with bracket, on top of battery box or actuator module, if installed.

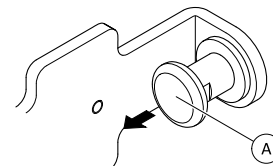

Fig. 6-37

5. Pull on strap (3) to move batteries (1) and battery support (2) forward.

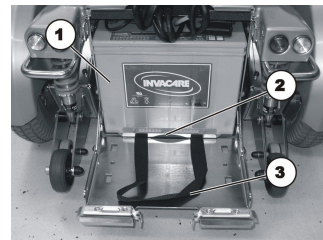

Fig. 6-38

### 6.10.4 Removing Batteries



- 11 mm socket wrench

#### Removing Batteries

1. Make batteries accessible. See *Making Batteries Accessible*.
2. Remove pole caps (A) on battery (C).
3. Remove pole screws under pole caps.
4. Remove connecting cable (D) and fuse cable (B).
5. Lift battery from battery tray.
6. Pull on strap of second battery to move it forward.
7. Dismantle cables on second battery as well.
8. Lift second battery from battery tray.

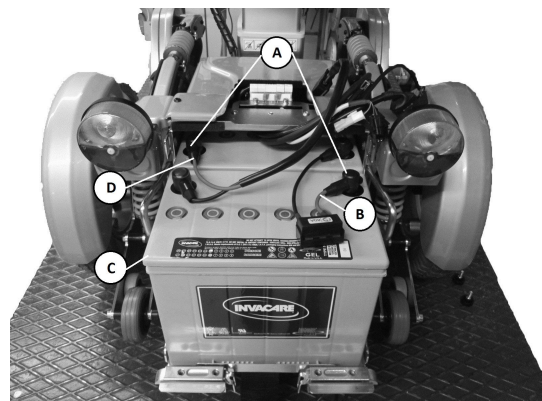

Fig. 6-39

#### Installing Batteries

1. Refit batteries in reverse order.
2. Make sure battery cage sockets/plugs have been correctly refitted. A polarity diagram is located in rear shroud.

### 6.10.5 Main Fuse



**CAUTION!**  
**Risk of fire**

A short circuit can cause extremely high currents which can result in spark formation and fire.  
 – Always use an original strip fuse with the approved amperage.  
 – If the main fuse has blown, first rectify the cause before fitting new one.



**CAUTION!**  
**Risk of fire and burns**

Fitting incorrect strip fuse causes fire hazard.  
 – Only fix strip fuses in sequence shown in image below.  
 – Tighten nuts with 3.3 or 3.5 Nm.

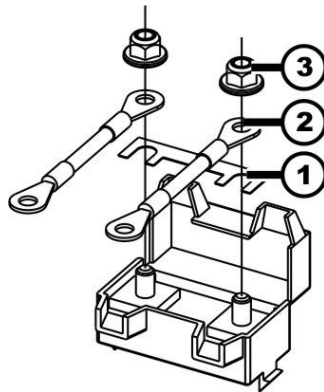

Fig. 6-40 Correct sequence of fitting original strip fuse

- |   |               |
|---|---------------|
| 1 | Strip fuse    |
| 2 | Ring terminal |
| 3 | DIN 6923 nut  |



- 8 mm socket wrench
- Strip fuse
- Flat screwdriver
- Torque wrench 0–20 Nm (or similar)



If the fuseholder is damaged, you can replace it completely with the battery cables.

#### Removing Main Fuse

1. Turn off mobility device.
2. Remove battery shroud, disconnect battery plugs and pull batteries out of battery box. See *Making Batteries Accessible*.
3. Fuse holder (1) is located on top of batteries.

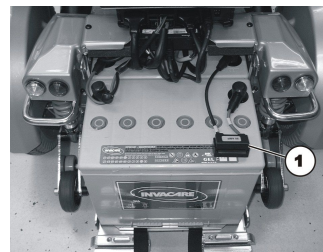

Fig. 6-41

4. Pry open snap hook (B) with flat screwdriver (C). Fuse holder shroud (A) is open.



Older fuse holder versions may be locked with tie wrap. If so, cut open tie wrap to access fuse strip.

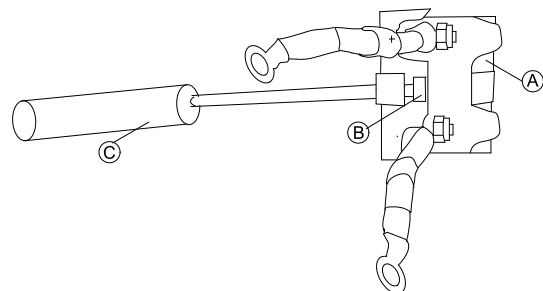

Fig. 6-42



5. You see strip fuse (2) once fuse holder (1) is open.
6. If strip fuse has blown, you must first ascertain and rectify the cause of the fault.
7. Main fuse may only be replaced once fault has been rectified.
8. Remove strip fuse nuts (3).

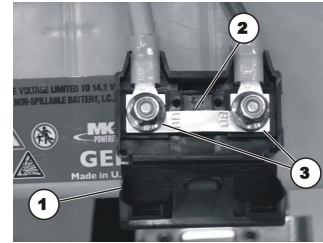





Fig. 6-43

9. Remove strip fuse.

### Installing Main Fuse

1. Replace strip fuse.
2. Install parts in reverse order.
  -  Make sure to press two parts of fuse holder shroud together until it snaps.
  -  If older fuse holder version is used, lock fuse holder with UL94V0 tie wrap.
3. Test all functions.

### 6.10.6 Cable Routing

- 
  - 4 mm Allen key
  - Oblique pliers
  - Cable ties

### Checking

1. Remove rear and centre shroud. See *6.6.1 Replacing Rear Shroud, page 21* and *6.6.2 Replacing Centre Shroud, page 21*).
2. Pull batteries out of battery box. See *Making Batteries Accessible*.
3. Check fuse cable (1) and battery cable (2) for visible damage and crushing points.
4. Check all cables for visible damage and crushing locations. Replace any damaged cables.
5. Pull each plug carefully. The plug should not come out of socket.
6. If one of plugs is loose, press it back into socket with light pressure. The plug must engage.
7. Make sure that plug is now firmly in socket. If not, repeat previous operation.
8. Install parts in reverse order.
9. Test all functions.

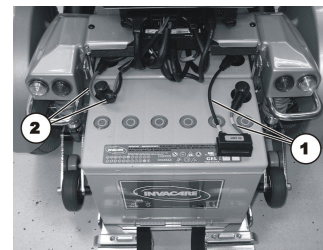

Fig. 6-44

## Installing

1. Remove rear and centre shroud. See 6.6.1 *Replacing Rear Shroud, page 21* and 6.6.2 *Replacing Centre Shroud, page 21*.
2. Lead cables on power module and actuator module fitted at rear through recess in battery flap under actuator module to cable bridge (1).
3. Lead cables inside shrouds over cable bridge (1).
4. Fasten cables with cable clamps (2). Cable clamps on front side of battery box for lifter cables (optional) are not seen in picture.

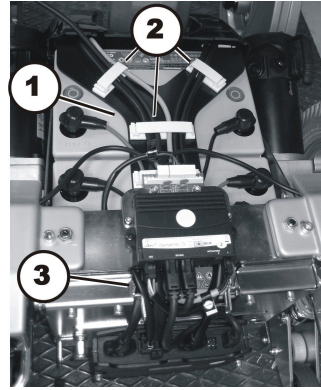

Fig. 6-45

5. Motor cables are fitted with protection shrouds (2) and are guided out of front shroud through recesses on side.
6. Cables that lead to seat (upper actuator module, remote, headlight), are guided out of front shroud through an upper left recess (3).
7. Make sure cable has enough play so that all movable parts can move freely without stretching, clamping or abrading cable.
8. Lay cables in same way under seat and to remote. Fasten cables with prescribed cable clamps or cable ties respectively.

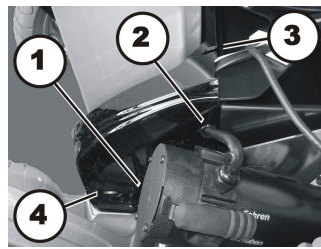

Fig. 6-46

## 6.11 Lighting Unit

### 6.11.1 Replacing front LED

It is not intended for an individual LED to be replaced. Replace the entire lighting unit as described in *Replacing headlight (LED)* or 6.11.3 *Replacing Headlight Holder (LED), page 51*.

### 6.11.2 Replacing Headlight (LED)



- 4 mm Allen key
- Oblique pliers
- Tie wraps

## Removing Headlight

1. Remove rear and centre shrouds. See 6.6.1 *Replacing Rear Shroud, page 21* and 6.6.2 *Replacing Centre Shroud, page 21*.
2. Take exact note of positions of all cables and sockets that cables are connected to. Mark connectors and sockets or take a photograph.
3. Open cable clamps (1), remove all tie wraps and pull cable out of mobility device.
4. Disconnect cable of affected headlight from light board (2).

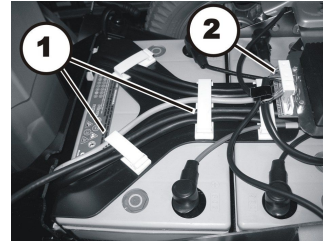

Fig. 6-47

5. Loosen screw (1) and remove headlight from holder.
6. Replace headlight.

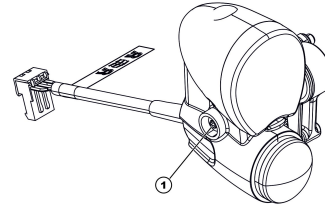

Fig. 6-48

## Installing Headlight

1. Install parts in reverse order.
2. Install cables carefully and secure them with cable clamps and tie wraps.
3. Tighten screws finger-tight.
4. Adjust headlight roughly using ratchet plate as a guide. The user can carry out final adjustment following user manual.
5. Test all functions.

### 6.11.3 Replacing Headlight Holder (LED)



- 4 mm Allen key
- 8 mm wrench
- Oblique pliers
- Tie wraps

## Removing Headlight Holder

1. Remove rear and centre shroud. See 6.6.1 *Replacing Rear Shroud, page 21* and 6.6.2 *Replacing Centre Shroud, page 21*.
2. Take exact note of positions of all cables and sockets that cables are connected to. Mark connectors and sockets or take a photograph.
3. Open cable clamps (1), remove all tie wraps and pull cable out of mobility device.
4. Disconnect cable of affected headlight from light board (2).
5. Loosen screw (1) and remove headlight from holder.
6. Loosen both nuts (2) and remove holder from rubber mounting.
7. Replace holder.

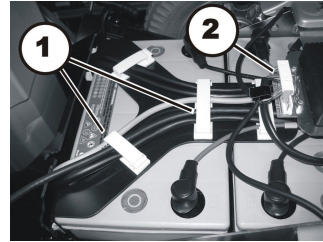

Fig. 6-49

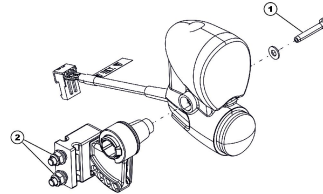



Fig. 6-50

## Installing Headlight Holder

1. Install parts in reverse order.
2. Install cables carefully and secure them with cable clamps and tie wraps.
3. Tighten screws finger-tight.
4. Adjust headlight roughly using ratchet plate as a guide. The user can carry out final adjustment following user manual.
5. Test all functions.

### 6.11.4 Replacing Complete Rear Light (LED)

 For the LED lighting unit the rear light shroud is the equivalent of a holder. To replace the rear light shroud, see 6.6.4 *Replacing Rear Light Shroud, page 22*.

-  • 4 mm Allen key  
 • 13 mm socket wrench  
 • Oblique pliers  
 • Tie wraps

## Removing Rear Light

1. Remove rear and centre shroud. See 6.6.1 *Replacing Rear Shroud, page 21* and 6.6.2 *Replacing Centre Shroud, page 21*.
2. Take exact note of positions of all cables and sockets that cables are connected to. Mark connectors and sockets or take a photograph.
3. Open cable clamps (1), remove all tie wraps and pull cable out of mobility device.
4. Disconnect cable of affected headlight from light board (2).

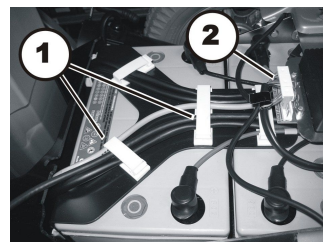

Fig. 6-51

5. Loosen nut (1).
6. Lift off rear light shroud (2) carefully.

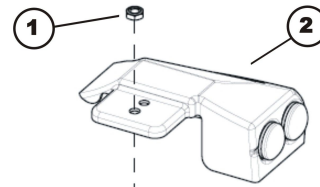

Fig. 6-52

7. Open rear light plug (3) that is to be replaced.
8. The rear lights are only clamped in plastic casing. Replace red rear light (1) or indicator (2) as required. Cables are marked correspondingly.

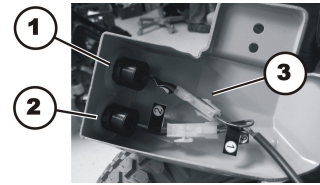

Fig. 6-53

### Installing Rear Light

1. Install all parts in reverse order.
2. Install cables carefully and secure them with cable clamps and tie wraps.
3. Test all functions.

## 6.12 Seating

This manual refers to configurations with standard seat system.

For other seat systems (for example Modulite), refer to the corresponding manual.

### 6.12.1 Replacing Seat Frame



**CAUTION!**  
**Risk of strain from lifting heavy parts!**  
 – Use proper lifting techniques.



- 6 mm Allen key
- 24 mm open-ended wrench
- Oblique pliers
- Cable ties

### Removing Seat Frame

1. Remove any existing cable ties holding cables on remote or lighting. Remove cables from stuck on clamps.
2. Loosen cap nuts of headlight mountings. See 6.11 *Lighting Unit, page 50*.
3. Put headlight and mounting in safe place on rear part of battery compartment shroud.
4. Remove all cables between seat and chassis.
5. Remove seat cushion.
6. Remove parts that are in the way, such as legrests and armrests.
7. Loosen two screws (A) and remove seat plate (B).
8. Remove backrest unit. See 6.16.5 *Replacing Backrest Bracket, page 64*.

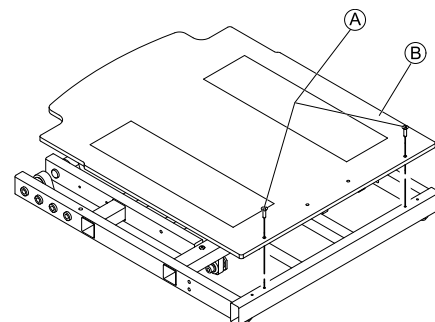

Fig. 6-54

9. Loosen and remove bolts (F), washers (E) and bushings (C) at front of seat frame. Pull out tilt sheet (D) and lay down seat frame carefully.

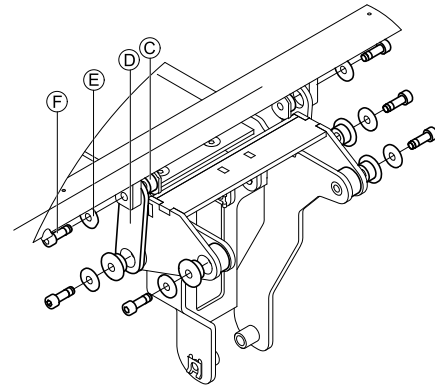

Fig. 6-55

10. Loosen and remove screws (G) and washers (H) at rear of seat frame.
11. Lift off seat frame including retaining sheets.

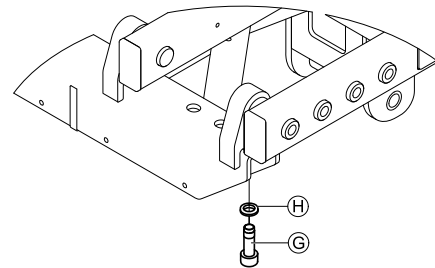

Fig. 6-56

### Installing Seat Frame

1. Install parts in reverse order.
2. Test all functions.

### 6.12.2 Replacing Tilt Spindle



- Oblique pliers

#### Removing Tilt Spindle

1. Remove upper pin retainer clip (A).
2. Remove upper pin (B) and tip tilt spindle (C) forward.
3. Remove lower pin retainer clip (F).
4. Remove lower pin (D) and tilt spindle. Take care of spacers (E).
5. Replace tilt spindle.

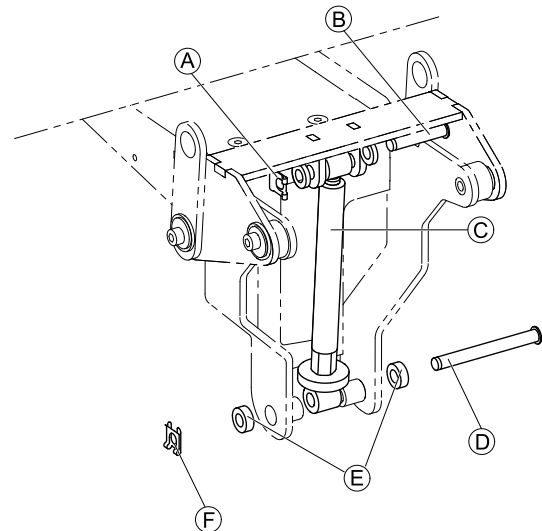

Fig. 6-57

#### Installing Tilt Spindle

1. Install parts in reverse order.
2. Test all functions.

### 6.12.3 Replacing Tilt Actuator



- Oblique pliers
- Cable ties

## Removing Tilt Actuator

1. Remove legrests.
2. Unplug actuator plug out of module.
3. Remove cable ties.
4. Remove cable.
5. Remove upper pin retainer clip (A).
6. Remove upper pin (B) and tip tilt actuator (E) forward.
7. Remove lower pin retainer clip (D).
8. Remove lower pin (C) and tilt actuator.
9. Replace tilt actuator.

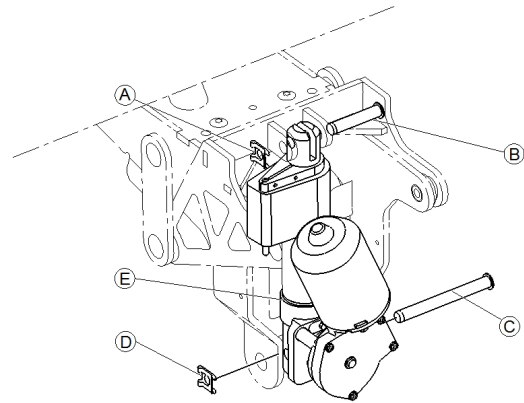

Fig. 6-58

## Installing Tilt Actuator

1. Install parts in reverse order.
2. Test all functions.

### 6.12.4 Replacing Tilt Bracket



**CAUTION!**  
**Risk of strains from lifting heavy parts!**  
 – Use proper lifting techniques.

We use different types of tilt carriers in our mobility devices. Due to this fact the carrier on your mobility device may look different to the illustrations below. The following mounting instructions are not affected by this.



- 6 mm Allen key

## Removing Tilt Bracket

1. Remove seat frame. See *Replacing Seat Frame*.
2. Remove tilt spindle or tilt actuator. See 6.12.2 *Replacing Tilt Spindle, page 54* (manual tilt) or 6.12.3 *Replacing Tilt Actuator, page 54* (powered tilt).
3. Loosen and remove screw (E), washer (D) and bushing (C) on both sides of seat support (A).
4. Replace tilt bracket (B).

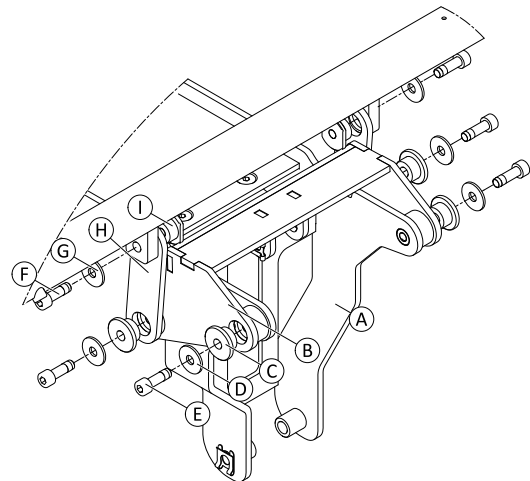

Fig. 6-59 Schematic diagram of a tilt bracket

## Installing Tilt Bracket

1. Install parts in reverse order. Ensure that holes of tilt sheet (H) and seat frame are in line.
2. Test all functions.

### 6.12.5 Replacing Seat Support



**CAUTION!**  
**Risk of strains from lifting heavy parts!**  
 – Use proper lifting techniques.



- TX40 Torx key
- Oblique pliers
- Cable ties

We use different types of seat supports in our mobility devices. Due to this fact the seat support and the screws on your mobility device may look different to the illustrations below. The mounting instructions are not affected by this.

### Removing Seat Support

1. Remove seat frame. See *Replacing Seat Frame*.
2. Loosen and remove four screws (A).
3. Lift off seat support (B) from seat / lifting column.

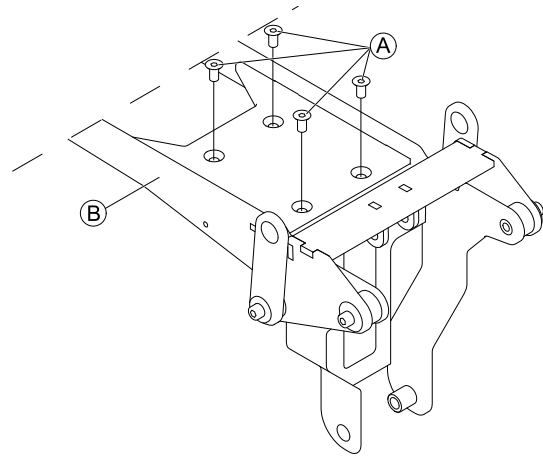

Fig. 6-60

### Installing Seat Support



#### CAUTION!

**Damage to lifter column possible. Using incorrect screws or inserting and tightening screws incorrectly will damage lifter column.**

The lifter column is supplied with self-tapping screws. The screws are used on underside as well as on upper side.

- Use only screws provided.
- If screws were already screwed in: When reinstalling screws, make sure that they are screwed carefully into existing thread.
- Tighten screws to a torque of 15 – 17 Nm.

1. Install parts in reverse order.
2. Test all functions.

### 6.12.6 Replacing Seat Column



#### CAUTION!

**Risk of strains from lifting heavy parts!**

- Use proper lifting techniques.



#### CAUTION!

**Risk of injury caused by uncontrolled movement of mobility device**

- Switch off power supply (ON/OFF key).
- Engage drive.
- Position mobility device on it's side and secure position so it does not turn over.



- TX40 Torx key
- Oblique pliers
- Cable ties



## Removing Seat Column

1. Remove seat. See 6.12.5 Replacing Seat Support, page 55.
2. Remove shrouds. See 6.6.1 Replacing Rear Shroud, page 21, 6.6.2 Replacing Centre Shroud, page 21 and 6.6.3 Replacing Front Shroud, page 22.
3. Place mobility device on side and safeguard it against overturning. Use proper lifting techniques.
4. Loosen and remove four screws (3) on underside of chassis (2).
5. Remove seat column (1).

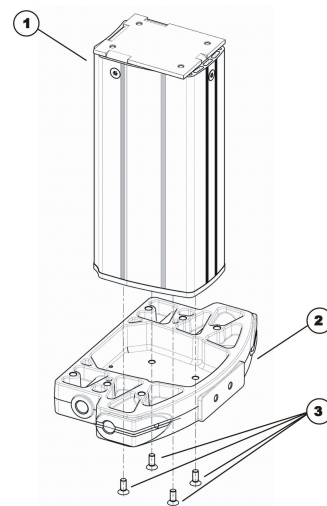

Fig. 6-61

## Installing Seat Column

1. Install parts in reverse order.
2. Test all functions.

## 6.13 Headrest/Neckrest

### 6.13.1 Replacing Rea Headrest

#### Removing Headrest

1. Loosen hand screw (B).
2. Pull headrest (A) out of bracket (C).

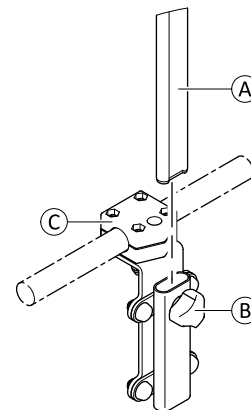

Fig. 6-62

#### Installing Headrest

1. Install parts in reverse order.
2. Tighten hand screw (B) hand-tight.
3. Test all functions.

### 6.13.2 Replacing Rea Headrest Mounting Bracket (Sling Backrest)



- 4 mm Allen key

#### Removing Bracket



Not all bolts and washers are shown in illustration.

1. Loosen and remove bolts (E) including washers (F), mounting plate (D) and bottom side of bracket (C).
2. Remove top side of bracket (B) including nuts (A).

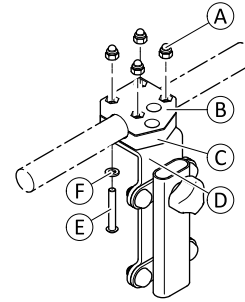



Fig. 6-63

### Installing Bracket

1. Install parts in reverse order.
2. Test all functions.

## 6.14 Replacing legrests

### 6.14.1 Replacing Footboard/Legrest Holder

-  • 5 mm Allen key

1. Loosen screw (B).
2. Pull footboard/legrest holder (C) out of seat frame (A).

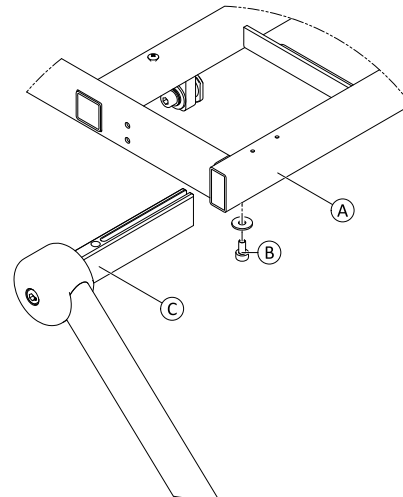



Fig. 6-64

### 6.14.2 Replacing Fixed Footboard

-  • 5 mm Allen key
- 19 mm wrench
  - Hot air gun
  - Thread locking adhesive, high-strength (Loctite 270 or similar)

1. Loosen four screws on both sides of footboard holder.
2. Pull out lower footboard assembly out of footboard holder.
3. Heat thread of screw from upside direction (see arrow) to soften thread locking adhesive. Loosen and remove screw ⑥.
4. Repeat previous step on second side.
5. Remove footboard assembly ① including washers ③ and ④.
6. Loosen and remove screws ⑤ and covering sheet ②.
7. Install parts in reverse order. Ensure to install screw ⑥ with new thread locking adhesive.
8. Insert lower footboard assembly into footboard holder.
9. Adjust lower footboard assembly to desired height. See *4.4 Adjusting Fixed Footboard, page 9*.

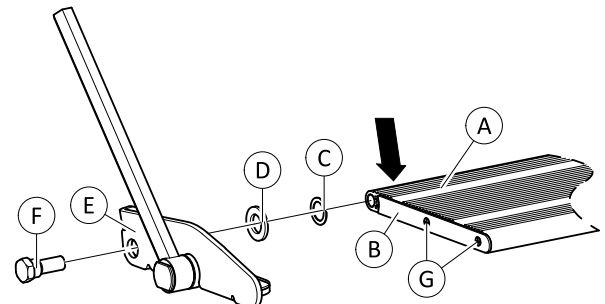

Fig. 6-65

### 6.14.3 Replacing Calf Pads

#### Replacing Calf Support



- 6 mm Allen key

1. Remove seat plate. See *6.12.1 Replacing Seat Frame, page 53*.
2. Remove calf pad.
3. Loosen and remove screws ④ including Nord-Lock washers ⑤ and calf support ③.
4. Remove T-nut ①.

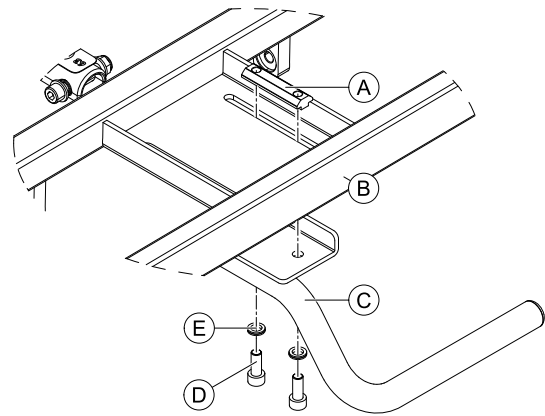

Fig. 6-66

5. Install parts in reverse order. Ensure correct installation of T-nut ① and calf support ③ on seat frame ②.
6. Test all functions.

#### Replacing Calf Pad



- 4 mm Allen key

1. Loosen screws ①.
2. Pull off calf pad ③ from calf support ②.
3. Install parts in reverse order.
4. Adjust position and angle of calf pad to user needs. See user manual.

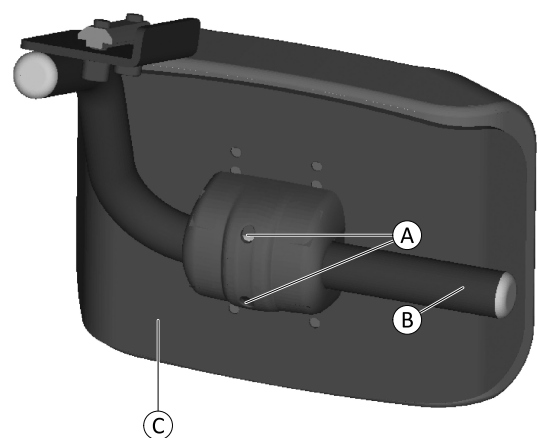



Fig. 6-67

## 6.15 Armrests

### 6.15.1 Replacing Armrest

#### Replacing Armpad

-  • 3 mm Allen key

1. Remove remote.
2. Loosen screw (B). Do not remove it.
3. Pull armpad bracket (C) out of clothes-guard assembly.
4. Loosen and remove screws (D).
5. Replace armpad (A).
6. Insert and re-tighten screws (D).

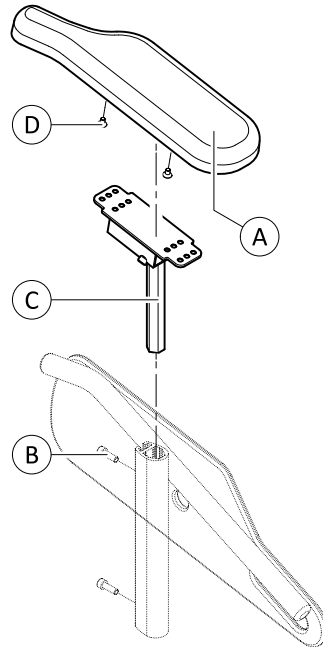



Fig. 6-68

#### Replacing Armpad Bracket

-  • 3 mm Allen key  
• 4 mm Allen key

1. Remove remote.
2. Loosen screw (B). Do not remove it.
3. Pull armpad bracket (C) out of clothes-guard assembly.
4. Loosen and remove screws (D).
5. remove armpad (A).
6. Replace armpad bracket (C).

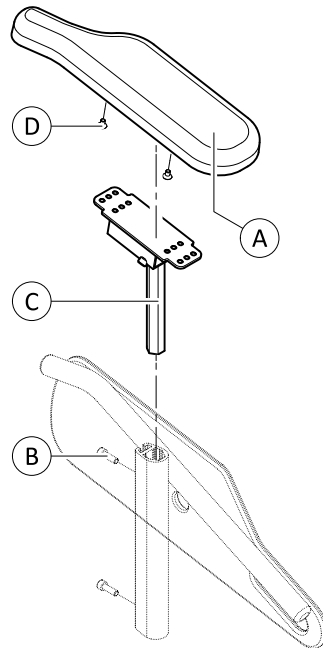

Fig. 6-69

7. Install parts in reverse order.
8. Test all functions.

## Replacing Clothes-Guard



- 4 mm Allen key
- Phillips screwdriver, size 2

1. Loosen and remove screws (A), saddle washers (C) and clothes-guard (B).
2. Replace clothes-guard (B).

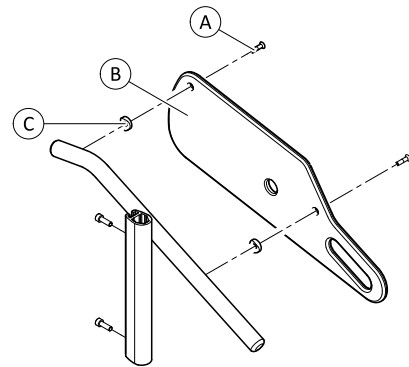

Fig. 6-70



When installing, ensure that saddle washer (C) is in the correct position.

3. Install parts in reverse order.
4. Test all functions.

## Replacing Armrest Bracket



- 4 mm Allen key
- 6 mm Allen key

1. Remove upper armrest assembly.
2. Loosen lever (D) and remove connection pin (E).
3. Loosen screws (B).
4. Remove clamp (C) from armrest bracket (A).

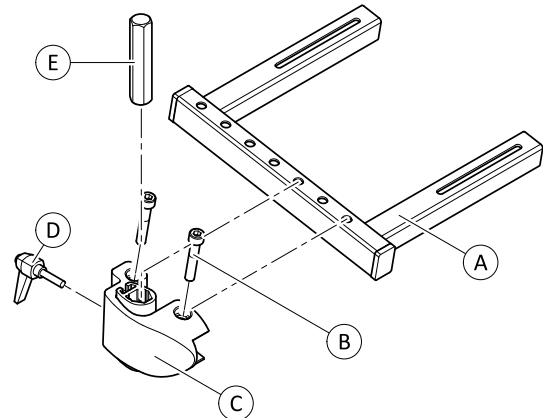

Fig. 6-71

5. If necessary, loosen two screws under seat frame and remove armrest bracket (A).
6. Install parts in reverse order.
7. Test all functions.

## 6.16 Backrest

### 6.16.1 Replacing Backrest Tube

1. Loosen handscrew © on both sides.
2. Pull backrest tube ① out of backrest rail ②.
3. Install parts in reverse order.
4. Test all functions.

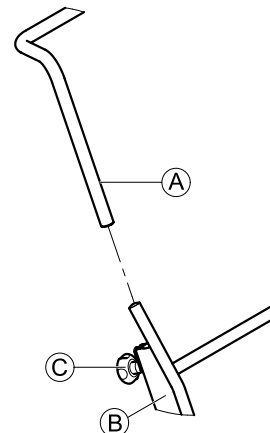

Fig. 6-72

### 6.16.2 Replacing Backrest Frame



- 5 mm Allen key

1. Loosen handscrews © on both sides and raise backrest tube ① as far as possible.
2. Re-tighten handscrews ©.

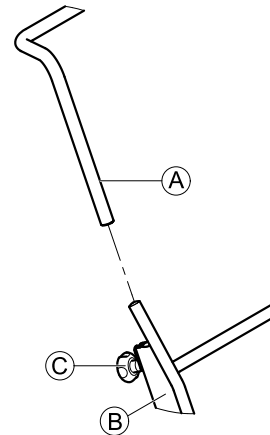

Fig. 6-73

3. Remove seat cushion.
4. Loosen screws ③. Do not unscrew them.
5. Remove backrest frame by lifting upwards.

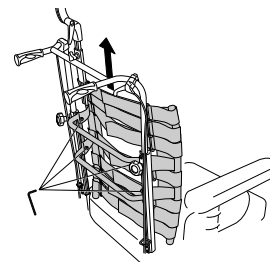



Fig. 6-74

6.  Ensure that T-nuts are on inner side of slot.

Install parts in reverse order.

7. Test all functions.

### 6.16.3 Replacing Backrest Rail



- 5 mm Allen key

1. Remove Backrest tube and backrest frame. See 6.16.1 *Replacing Backrest Tube, page 62* and 6.16.2 *Replacing Backrest Frame, page 62*.
2. Loosen handscrew of locking slide ©.
3. Remove backrest rail ① by lifting upwards from backrest bracket ②.

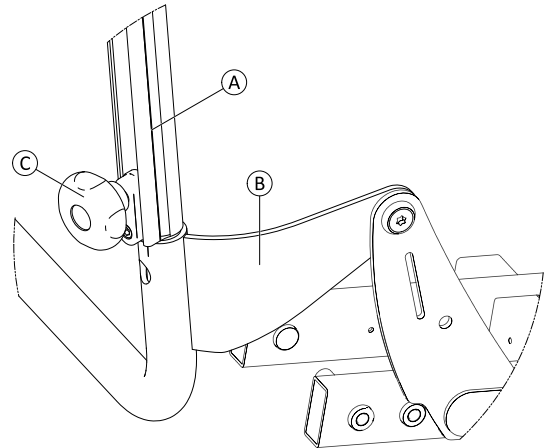

Fig. 6-75

4. Loosen screws ④ of locking slides.
5. Remove all locking slides © from backrest rail ①.

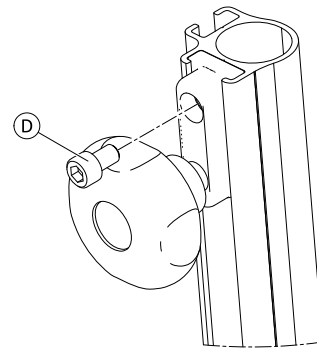

Fig. 6-76

6. Install parts in reverse order.
7. Test all functions.

#### 6.16.4 Replacing Seat Depth Adapter



- 5 mm Allen key

1. Remove backrest frame and backrest tube. See 6.16.3 *Replacing Backrest Rail*, page 62.
2. Loosen four screws ④ on each side. Do not unscrew them.
3. Remove backrest rail ① by pulling it upwards.

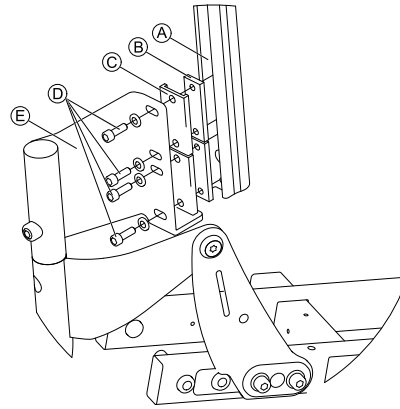

Fig. 6-77

4. Loosen set screw ①.
5. Lift off adapter ⑤ from backrest bracket.

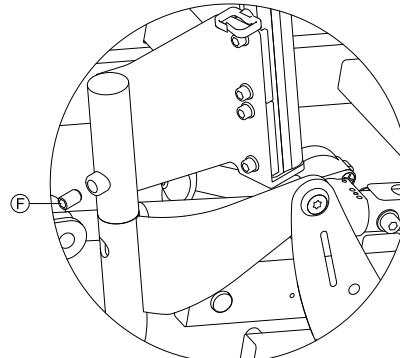

Fig. 6-78

6.
  - ⓘ Ensure that guide ③ is on outside and T-nut ② is on inside of slot

Install parts in reverse order.

7. Test all functions.

### 6.16.5 Replacing Backrest Bracket

- 5 mm Allen key
- 6 mm Allen key
- Flat screwdriver

1. Loosen handscrews / screws ① on both sides and remove upper backrest assembly.

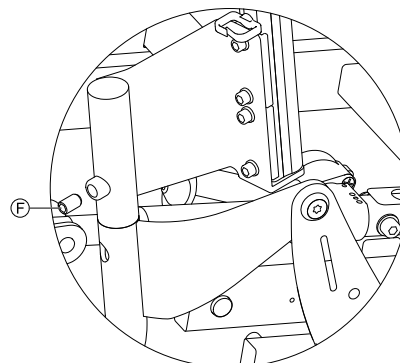

Fig. 6-79 Example of Max seat with installed seat depth adapter

2. Remove retainer clip ③.
3. Keep firm hold on backrest bracket ② whilst removing pin ④ and laying down actuator / spindle ⑤.
4. Secure backrest bracket ② against falling down.

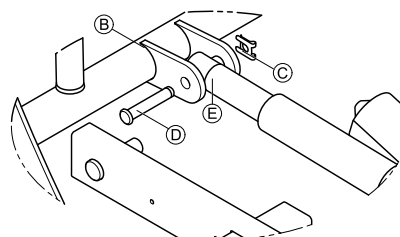

Fig. 6-80



5. Loosen and remove screws ① including washers ② and bushings ③ on both sides.
6. Remove backrest bracket ④.
7. Loosen and remove screws ⑤, washers ⑥, cover plates ⑦ and bearing sheet ⑧ on both sides.

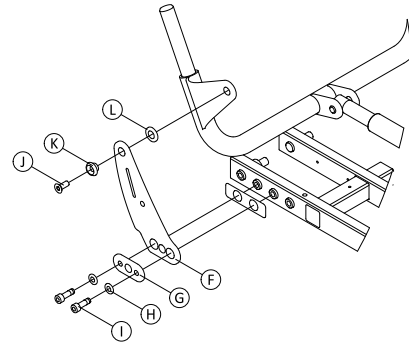

Fig. 6-81

8. Install parts in reverse order.
9. Test all functions.

## 6.17 Posture Belt

### 6.17.1 Replacing Posture Belt

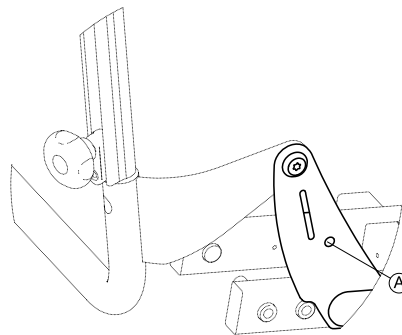

Fig. 6-82 Lap Belt installation hole on Max seat

#### Pre-Assembling Belts

**i** Another nut ⑤ is installed in installation hole ④ between washers as a spacer, so that the belt bracket can move freely.

1. Install parts in following order:

- Bolt ②,
- washer ③,
- belt ④,
- spacer nut ⑤, and
- washer ⑥.

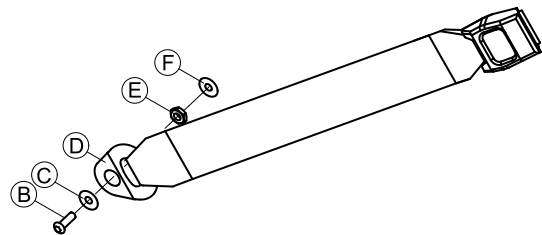

Fig. 6-83

#### Removing Lap Belt



- 4 mm Allen key
- 10 mm wrench

1. Loosen and remove nut ① including washer ①.

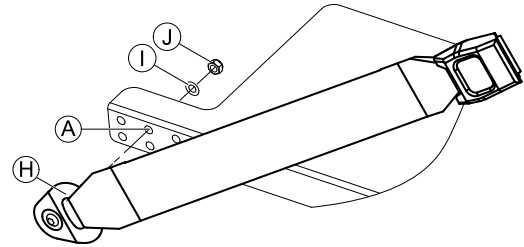

Fig. 6-84 Example of a lap belt on a Storm<sup>4</sup>

2. Remove bolt ⑥ and belt ④. Pay attention to washers (③ and ⑦) and nut ⑤.

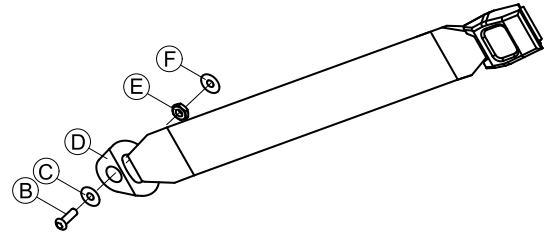



Fig. 6-85

### Installing Lap Belt

-  • 4 mm Allen key
-  • 10 mm wrench

1. Insert pre-assembled lap belt ⑧ into installation hole ④.
2. Insert washer ① and nut ①.
3. Tighten nut ①.

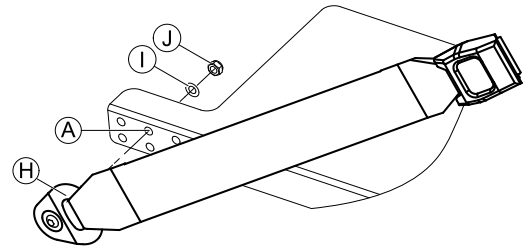



Fig. 6-86 Example of a lap belt on a Storm<sup>4</sup>

### Replacing Harness Belt (H-Belt)

-  • 5 mm Allen key
-  • 13 mm wrench

1. Remove plastic cap (2).
2. Loosen and remove screw (6), associated washers (5) and nuts (4) (in front of the/behind the gripper clamp (3)).
3. Replace harness belt (1).
4. Install new parts in reverse order.
5. Test all functions.

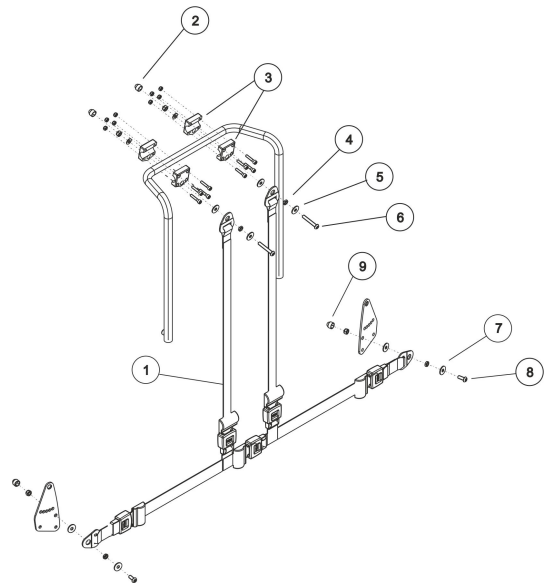

Fig. 6-87

### Replacing Lap Belt (H-Belt)

See *Removing Lap Belt* and *Installing Lap Belt*.



## Invacare Distributors

### Australia:

Invacare Australia Pty. Ltd.  
1 Lenton Place, North Rocks NSW  
2151  
Australia  
Phone: 1800 460 460  
Fax: 1800 814 367  
orders@invacare.com.au  
www.invacare.com.au

### United Kingdom:

Invacare Limited  
Pencoed Technology Park, Pencoed  
Bridgend CF35 5AQ  
Tel: (44) (0) 1656 776 222  
Fax: (44) (0) 1656 776 220  
uk@invacare.com  
www.invacare.co.uk

### Canada:

Invacare Canada L.P.  
570 Matheson Blvd East, Unit 8  
CDN Mississauga, On. L4Z 4G4  
Phone: (905) 890 8300  
Toll Free: 800.668.5324  
www.invacare.ca

### Eastern Europe, Middle East & CIS:

Invacare EU Export  
Am Achener Hof 8  
D-88316 Isny  
Tel: (49) (0)7562 700 397  
eu-export@invacare.com  
www.invacare-eu-export.com

### Ireland:

Invacare Ireland Ltd,  
Unit 5 Seatown Business Campus  
Seatown Road, Swords, County Dublin  
Tel : (353) 1 810 7084  
Fax: (353) 1 810 7085  
ireland@invacare.com  
www.invacare.ie

### New Zealand:

Invacare New Zealand Ltd  
4 Westfield Place, Mt Wellington 1060  
New Zealand  
Phone: 0800 468 222  
Fax: 0800 807 788  
sales@invacare.co.nz  
www.invacare.co.nz

