

Invacare® Dragon Vertic
SERVICE INSTRUCTIONS



Edition: 10.04.12



Yes, you can.®

These instructions contain information about:

Testing work

Repair Instructions

This manual is part of the instructions for use.

Service addresses

A	Invacare Austria GmbH	(:	+43 6232 5 53 50
	Herzog Odilostrasse 101	Fax:	+43 6232 5 53 54
	A-5310 Mondsee	@:	info@invacare-austria.com
	Austria	WWW:	www.invacare.at

B	Invacare n.v.	(:	+32 (0)50 83 10 10
	Autobaan 22	Fax:	+32 (0)50 83 10 11
L	B-8210 Loppem (Brugge)	@:	belgium@invacare.com
	Belgium	WWW:	www.invacare.be

CH	Invacare AG	(:	+41 (0)61487 70 80
	Benkenstraße 260	Fax:	+41 (0)61487 70 81
	CH-4108 Witterswil	@:	switzerland@invacare.com
	Switzerland	WWW:	www.invacare.ch

D	Invacare Aquatec GmbH	(:	+49 (0)7562 70 00
	Alemannenstraße 10	Fax	+49 (0)7562 7 00 66
	88316 Isny	@:	info@invacare-aquatec.com
	Deutschland	WWW:	www.invacare-aquatec.de

DK	Invacare A/S	((Kundeservice):	+45 (0)36 90 00 00
	Sdr. Ringvej 37	Fax (Kundeservice):	+45 (0)36 90 00 01
	DK-2605 Brøndby	@:	denmark@invacare.com
	Danmark	WWW:	www.invacare.dk

E	Invacare® SA	(:	+34 (0)972 49 32 00
	c/ Areny s/n	Fax:	+34 (0)972 49 32 20
	Polígon Industrial de Celrà	@:	contactsp@invacare.com
	E-17460 Celrà (Girona)	WWW:	www.invacare.es
ESPAÑA			

F	Invacare® Poirier SAS	(:	+33 (0)247 62 64 66
	Route de St Roch	Fax:	+33 (0)247 42 12 24
	F-37230 Fondettes	@:	contactfr@invacare.com
	France	WWW:	www.invacare.fr

GB	Invacare® Ltd Pencoed Technology Park Pencoed Bridgend CF35 5HZ United Kingdom	((Customer services): +44 (0)1656 77 62 22 Fax (Customer services): +44 (0)1656 77 62 20 @: uk@invacare.com WWW: www.invacare.co.uk
I	Invacare Mecc San s.r.l. Via dei Pini, 62 I - 36016 Thiene (VI) Italia	(: +39 0445 38 00 59 Fax: +39 0445 38 00 34 @: italia@invacare.com WWW: www.invacare.it
IE	Invacare Ireland Ltd. Unit 5 Seatown Business Campus Seatown Rd, Swords County Dublin Ireland	(: +353 18 10 70 84 Fax: +353 18 10 70 85 @: ireland@invacare.com WWW: www.invacare.ie
N	Invacare® AS Grensesvingen 9 Postboks 6230 Etterstad N-0603 Oslo Norge	((Kundeservice): +47 (0)22 57 95 00 Fax (Kundeservice): +47 (0)22 57 95 01 @: norway@invacare.com @: island@invacare.com WWW: www.invacare.no
NL	Invacare® B.V. Celsiusstraat 46 NL-6716 BZ Ede Nederland	(: +31 (0)318 69 57 57 Fax: +31 (0)318 69 57 58 @: nederland@invacare.com @: csede@invacare.com WWW: www.invacare.nl
P	Invacare Lda Rua Estrada Velha, 949 P-4465-784 Leça do Balio Portugal	(: +351 225 10 59 46 ☒ : +351 225 10 59 47 Fax: +351 225 10 57 39 @: portugal@invacare.com WWW: www.invacare.pt

S	Återförsäljare:	((Kundtjänst):	+46 (0)8 761 70 90
	Invacare® AB	Fax (Kundtjänst):	+46 (0)8 761 81 08
FIN	Fagerstagatan 9	@:	sweden@invacare.com
	S-163 91 Spånga	@:	finland@invacare.com
	Sverige	WWW:	www.invacare.se

Tillverkare:	MÖLNDAL		
Invacare® Deutschland GmbH	(□	+46 (0)31 86 36 00	
Kleiststraße 49	Fax:	+46 (0)31 86 36 06	
D-32457 Porta Westfalica	@:	ginvacare@invacare.com	
Deutschland			

	LANDSKRONA		
☒ :		+46 (0)418 2 85 40	
Fax:		+46 (0)418 1 80 89	
@:		linvacare@invacare.com	

	OSKARSHAMN		
☒ :		+46 (0)491 1 01 40	
Fax:		+46 (0)491 1 01 80	
@:		oinvacare@invacare.com	

Eastern european countries	European Distributor Organisation (EDO)	(+49 (0)5731 75 45 40
	Kleiststraße 49	Fax	+49 (0)5731 75 45 41
	D-32457 Porta Westfalica	@:	edo@invacare.com
	Deutschland	WWW:	www.invacare.de

Table of Contents

Chapter	Page
1 INTRODUCTION	7
1.1 General information	7
1.2 Notes on transport	7
1.3 Important symbols in this manual	7
2 SAFETY AND ASSEMBLY INSTRUCTIONS	9
2.1 Before any inspection or repair work	9
2.2 General safety information and notes on assembly / disassembly	9
3 TIGHTENING TORQUES	11
4 ALLOCATION OF THE SUB-ASSEMBLIES AND COMPONENTS	12
5 MAINTENANCE PLAN (ONCE A YEAR)	13
6 OPERATIONAL FAULTS	15
6.1 Operational disturbances on wheelchair with ACS	15
6.1.1 Drive disturbance diagnostics	15
6.1.2 Diagnostics involving disturbances with electric regulating motors	17
6.1.3 REM24 error codes and diagnostics codes	18
6.2 Operational faults on a wheelchair fitted with Shark electronics	20
6.2.1 Diagnosis of actuation disorders	20
6.2.2 Shark error codes and diagnostic codes	22
7 REPAIR WORK	24
7.1 General warning information on installation work	24
7.2 Replacing a motor	24
7.3 Replacing the Shark Electronics	28
7.4 Updating the driving program	30
7.5 Changing the batteries	31
7.5.1 Removing the batteries	31
7.5.2 How to handle damaged batteries correctly	32
7.6 Checking and replacing the main fuse	33

7.7	Checking the cables	35
7.8	Replacing the Shark II Remote	37
7.9	Replacing the ACS Remote	38
7.10	Replacing the steering head bearings on the steering wheels	40
7.11	Repairing a flat tyre	42
7.11.1	Repairing the flat tyre (pneumatic tyre equipment type 12½ x 2¼")	42
7.11.2	Repairing a flat tyre (pneumatic tyre equipment type 220/120 x 50)	43
7.12	Replacing a drive wheel	45
7.13	Checking a regulating motor	46
7.14	Replacing the verticalizer actuator	46
7.15	Replacing the safety belt	48
7.16	Chest strap	49
7.16.1	Replacing the chest strap	49
7.16.2	Replacing the additional belt	50
8	ADJUSTING THE WHEELCHAIR TO THE USER'S SEATING POSTURE	51
8.1	Adjusting the seat depth	51
8.2	Legrest	53
8.2.1	Setting the lower leg length of the legrest	53
8.3	Changing the height of the backrest	54
8.4	Restraining straps for the legs	57
8.4.1	Opening and closing the restraining strap	57
8.4.2	Adjusting the position of the release lever	57
8.4.3	Adjusting the retaining bar and knee cushions	58
8.4.3.1	Setting the depth of the restraining strap	58
8.4.3.2	Adjusting the height of the knee cushions	59
8.4.3.3	Setting the width of the knee cushions	60
8.5	Adjusting the armrests and the control panel	61
8.5.1	Adapting the height of the armrests	61
8.5.2	Setting the angle of the swing-up armrest	61
8.5.3	Setting the resistance of the swing-up armrest	62
8.5.4	Adapting the control panel to the length of the user's arm	62
8.5.5	Setting the height of the remote	63
8.5.6	Adjusting the width of the armrests	63
8.6	Adapting the height of the chest belt	64
8.7	Adjusting the headrest	65
8.7.1	Adjusting the height	65
8.7.2	Setting the position	65
8.8	Adjustment of the stand-up angle	66

1 Introduction

1.1 General information

- All maintenance and overhaul work must be carried out in accordance with these repair instructions.
- Please observe all safety instructions.
- Information about operation or about general maintenance and care work should be taken from the electric vehicle Operating Manual.
- You can find information about ordering spare parts in the spare parts catalogue.
- Use only genuine Invacare® spare parts. Using parts from any other source will void the warranty!
- We reserve the right to make any alterations on the grounds of technical improvements.
- The electric vehicle may only be maintained and overhauled by qualified personnel.
- The minimum requirement for service technicians is relevant training, such as in the cycle or orthopaedic mechanics fields, or suitably long-term job experience.
 - Experience and knowledge of electrical measuring devices (Multimeter) is also a requirement.
 - Special Invacare training sessions are recommended.
- Alterations to the electric vehicle which occur as a result of incorrectly or improperly executed maintenance or overhaul work lead to the exclusion of all liability on the part of INVACARE.
- If you have any problems or questions please contact INVACARE SERVICE.

1.2 Notes on transport

- If the electric vehicle has to be shipped back to the manufacturer for major repairs, you should always use the original packaging for transport.
- You should also include as accurate a fault description as possible.

1.3 Important symbols in this manual



General risks

This symbol warns you of general hazards!

- *Always follow the instructions to avoid injury to the user or damage to the product.*
-



EXPLOSION HAZARD!

This symbol warns you of an explosion hazard, which can be caused by excessive tyre pressure in a pneumatic tyre.

- *Always follow the instructions to avoid injury to the user or damage to the product.*
-



BURN HAZARD!

This symbol warns you of the danger of chemical burns, for example due to the discharge of battery acids!

- *Always follow the instructions to avoid injury to the user or damage to the product.*
-

**BURN Risk!**

This symbol warns of the risk of burns, for example, as a result of hot motor surfaces.

- Follow the instructions in order to avoid injury or damage to the product.

**RISK OF CRUSHING!**

This symbol warns of a risk of crushing caused by being careless with heavy components.

- Always follow the instructions to avoid injury to the user or damage to the product.

**Wear eye protection**

This symbol refers to the requirement for wearing eye protection, for example when working with batteries.

- You must wear safety goggles when this symbol is displayed.

**Wear protective gloves**

This symbol indicates the requirement to wear protective gloves, for example when working with batteries.

You must wear protective gloves when this symbol is displayed.

**NOTE:**

This symbol identifies general information which is intended to simplify working with your product and which refers to special functions.

**Requirements:**

- This symbol identifies a list of various tools, components and items which you will need in order to carry out certain work. Please do not attempt to carry out the work if you do not have the listed tools available.

2 Safety and assembly instructions

These safety instructions are intended to prevent accidents during work and it is imperative that they are observed.

2.1 Before any inspection or repair work

- Read and observe this repair manual and the associated operating manual!
- Observe the minimum requirements for carrying out the work (see chapter entitled "General information")!

2.2 General safety information and notes on assembly / disassembly



Danger of injury by crushing!

- *Please note the heavy weight of some components. This applies especially to removal of drive units and batteries!*
 - *Prop up the lifted electric vehicle with appropriate supports before starting the disassembly or assembly!*
-



Danger of fire and burns due to electrical short-circuit!

- *The electric vehicle must be switched off before removal of voltage-carrying components! To do this, disconnect the batteries!*
 - *When making measurements on voltage-carrying components, avoid short-circuiting the contacts. Danger of fire and combustion!*
-



Danger of injury and damage to the vehicle can result from incorrect or incomplete maintenance!

- *Only ever use tools which are undamaged in good condition!*
 - *Some moving parts have Teflon bushings! These parts must never be lubricated with grease!*
 - *Never use standard nuts instead of self-locking nuts!*
 - *Always use correctly dimensioned washers or spacers!*
 - *Cable binders which have been cut off during disassembly should be replaced with new ones during reassembly!*
 - *After completing maintenance work and before operating the electric vehicle, make sure all fixations are correctly secured! Check all parts for correct interlocking!*
 - *Only operate the electric vehicle with correct tyre pressure (see Technical Specifications)!*
 - *Check electrical components for correct functioning, incorrect polarity of cables can result in damage to the electronics!*
 - *As a last check, always carry out a test-drive!*
-



Notes

Mark all current settings for the electric vehicle (seat, armrests, backrest etc.), and the cable connecting plugs associated, before any removals. This makes reassembly easier. All plugs are fitted with mechanical safety devices which prevent release of the connecting plugs during operation. To release the connecting plugs the safety devices must be pressed in. When reassembling, ensure that these safety devices are correctly engaged.



WARNING: Any alteration to the drive programme can influence vehicle handling and the tipping stability of the electric vehicle!

- *Alterations to the drive programme may only be carried out by trained Invacare® dealers!*
 - *Invacare® supplies all electric vehicles from the factory with a standard drive programme. Invacare® can only assume a warranty for the safe vehicle handling of the electric vehicle – in particular tipping stability - for this standard drive programme!*
-

3 Tightening torques

The tightening torques stated in the following table are dependent on the thread diameters for the nuts and bolts for which no special values are determined. All values apply to dry and grease-free threads.

Thread	M4	M5	M6	M8	M10	M12	M14	M16
Tightening torque in Nm $\pm 10\%$	3 Nm	6 Nm	10 Nm	25 Nm	49 Nm	80 Nm	120 Nm	180 Nm

Caution: All other nuts or plastic connectors not noted here must be tightened FINGERTIGHT!

4 Allocation of the sub-assemblies and components

Under the seat:

- 1) Disengaging mechanism
- 2) Power module (cover removed)

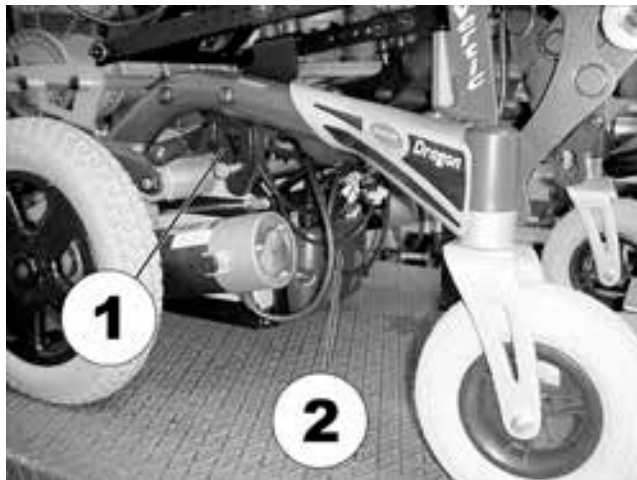

Under the battery cover

- 3) Main fuse for the batteries

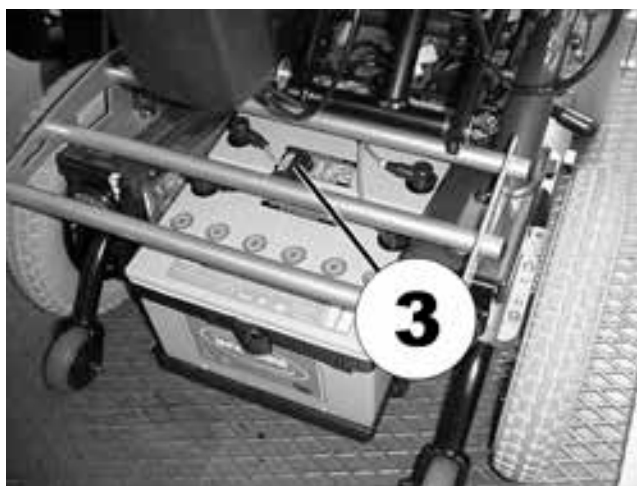

Under the raised upright mechanism

- 4) Control box of the verticalizer limit stop
- 5) Actuator of the verticalizer



5 Maintenance plan (once a year)

Component	Check for	Measures	Remarks	Ü
Armrests and side sections	<ul style="list-style-type: none"> Damage and fastening of the armrests Damage and screw connections on the side sections 	<ul style="list-style-type: none"> Tighten screws, replace support plate if damaged Tighten screws, replace side sections if damaged 		
Chest belt	<ul style="list-style-type: none"> Chest belt must fit snugly. Check velcro strip for correct functioning. Velcro strip must not open by itself. 	<ul style="list-style-type: none"> Replace if damaged or if velcro function is affected. 		
Electric backrest (if available)	<ul style="list-style-type: none"> Damage and seams Fastening Check cable Test function 	<ul style="list-style-type: none"> Replace parts if damaged Tighten screws Replace cable or motor if necessary 		
Upright mechanism	<ul style="list-style-type: none"> Check welding seams for damage Check tight fit of the screwed fixings Check correct function of the actuator 	<ul style="list-style-type: none"> Replace upright mechanism if necessary Tighten screwed fixings Replace actuator if necessary 		
Frame (chassis) / battery receptacle	<ul style="list-style-type: none"> Check fastenings, welding seams and battery receptacle 	<ul style="list-style-type: none"> Tighten screws, replace components 		
Wheel suspension and wheels	<ul style="list-style-type: none"> Check tight fit of the drive wheels and axial run out 	<ul style="list-style-type: none"> Adjust, replace wheel hubs 	See "Replacing a drive wheel" on page 45	
	<ul style="list-style-type: none"> Check steering wheels for tight fit, float, side play and correct torque (15 Nm +/- 1.5 Nm) 	<ul style="list-style-type: none"> Replace wheels, wheel fork or wheel bearing 	See "Replacing the steering head bearings on the steering wheels" on page 40	
	<ul style="list-style-type: none"> Pneumatic tyres (if available) 	<ul style="list-style-type: none"> Repair or replace if damaged 	See "Repairing a flat tyre" on page 42	
	<ul style="list-style-type: none"> Check support rollers of the legrest receptacles for damage 	<ul style="list-style-type: none"> Replace support rollers if necessary 		
Drive units, coupling mechanism	<ul style="list-style-type: none"> Check functions during drive operation and when pushing Check coupling mechanism 	<ul style="list-style-type: none"> Replace motor if necessary Tighten screws/nuts, adjust or replace if necessary 		

Component	Check for	Measures	Remarks	Ü
Legrests	<ul style="list-style-type: none"> Check welding seams, locking devices, screws and foot plates 	<ul style="list-style-type: none"> Tighten or replace if necessary 		
Electric legrests (if available)	<ul style="list-style-type: none"> Check cable Check contacts Check functions 	<ul style="list-style-type: none"> Replace cable if necessary 		
Lighting (if available)	<ul style="list-style-type: none"> Check cable Check function 	<ul style="list-style-type: none"> Replace bulbs or cable if necessary 		
Batteries	<ul style="list-style-type: none"> Check batteries for damage 	<ul style="list-style-type: none"> Replace batteries if necessary 	See "Changing the batteries" on page 31	
	<ul style="list-style-type: none"> Check battery voltage 	<ul style="list-style-type: none"> Charge batteries 	See instruction manual	
	<ul style="list-style-type: none"> Check contacts and pole clamps 	<ul style="list-style-type: none"> Clean contacts and pole clamps 	See "Changing the batteries" on page 31 for safety information when handling batteries	
Remote / drive electronic system	<ul style="list-style-type: none"> Remote, status display flashing Fastening Cable, plug connection Joystick function Voltage supply 	<ul style="list-style-type: none"> Evaluate flashing code Tighten, replace Replace Replace joystick Replace cable, plug connection or remote 		
Driving Programme	<ul style="list-style-type: none"> Check the programme version of the driving electronics. Is there a newer version available? 	<ul style="list-style-type: none"> Update the software. 	See "Updating the " on page 30	

6 Operational Faults

6.1 Operational disturbances on wheelchair with ACS

In the event of problems with the wheelchair, please proceed as follows:

Begin by assessing the possible cause of disturbance on the basis of the following tables. Check the remote status display. Evaluate the flashing error code.

- Carry out the necessary examinations and repairs as recommended in the following table.

6.1.1 Drive disturbance diagnostics

PROBLEM	OTHER SYMPTOMS	POSSIBLE CAUSE	SOLUTION	DOCUMENTATION
Wheelchair will not start up	Status display on the remote illuminates as usual and does not display an error code	Drive motors possibly disengaged	· Engage drive motors	See instruction manual
	Status display on the remote is not illuminated	Batteries possibly faulty	· Replace batteries	See " Changing the batteries " on page 31
		Battery power possibly low	· Recharge batteries	See instruction manual
		Power supply to remote possibly interrupted	· Check main fuse	See " Checking and replacing the main fuse " on page 33
			· Check cable between the modules for loose connections or damage	See " Checking the cables " on page 35
	Remote possibly faulty	· Replace remote on the wheelchair in order to exclude the possibility that the remote is the cause.	See " Replacing the Shark II Remote " on page 37	
	Status display on the remote is flashing	Various causes	· Evaluate error code	See " REM24 error codes and diagnostics codes " on page 18
Status display on remote flashes twice, drive display is on "U"	Speed controller on the verticalizer actuator is possibly faulty or not connected	· Replace the actuator	See " Replacing the verticalizer actuator " on page 46	

Wheelchair judders during drive operation	None	Batteries possibly faulty (unstable voltage)	· Replace batteries	See " Changing the batteries " on page 31
		Drive motor(s) possibly faulty	· Replace motor(s)	See " Replacing a motor " on page 24
Batteries are not being charged	None	Batteries possibly faulty	· Replace batteries	See " Changing the batteries " on page 31
	LEDs flashing on charger	Charger possibly faulty	· Replace charger	See charger instruction manual
Wheelchair driving too slowly	Status display on remote flashes twice, drive display is on "U"	Seat lifter is not in drive position (either too high or too low) and has activated automatic speed control.	· Move seat lifter to drive position	See instruction manual
	None	Remote is possibly faulty	· Replace remote	See " Replacing the Shark II Remote " on page 37
		Batteries possibly faulty	· Replace batteries	See " Changing the batteries " on page 31

6.1.2 Diagnostics involving disturbances with electric regulating motors

Assess the cause of the disturbance involving an electric regulating motor on the basis of the following table:

PROBLEM	OTHER SYMPTOMS	POSSIBLE CAUSE	SOLUTION	DOCUMENTATION
Electric regulating motor not reacting	Remote displays flashing "E", status diode on light/regulating module does not extinguish even if the remote is shut down or disconnected	Light /regulating module faulty	<ul style="list-style-type: none"> Replace light /regulating module 	See " Replacing the Shark Electronics " on page 28
	None	Cable possibly severed or damaged	<ul style="list-style-type: none"> Check that the cable has not been severed or damaged. Replace cable if necessary 	See " Checking the cables " on page 35
		Electric regulating motor possibly faulty	<ul style="list-style-type: none"> Test regulating motor 	See " Checking a regulating motor " on page 46
		Remote possibly faulty	<ul style="list-style-type: none"> Replace remote on wheelchair in order to exclude the possibility that the remote is the cause of the disturbance. 	See " Replacing the Shark II Remote " on page 37

6.1.3 REM24 error codes and diagnostics codes

The drive electronic system can automatically rectify certain disturbances. In this case the status display stops flashing. Please switch the remote on and off several times. Wait approximately 5 seconds each time before switching the remote on again. In case the error is not rectified by this, assess the cause on the basis of the following flashing code.

Flashing code:	Significance:	Solution:	Flashing code:
Flashes once	Module faulty	Replace faulty module	See " Replacing the Shark Electronics " on page 28
Flashes twice	Faulty accessory (e.g. short circuit on regulating motor)	<ul style="list-style-type: none"> Check accessory connections, check accessories 	See " Checking a regulating motor " on page 46
	Lifter too high or too low (seat not at drive height)	<ul style="list-style-type: none"> Whilst the lifter is raised, lower slowly until the status display stops flashing. If the lifter is too low, raise slowly until the status display stops flashing. Only drive when the seat is at the correct drive height. 	See instruction manual
Flashes three times	Fault on r.h. motor.	<ul style="list-style-type: none"> Check the connecting plug Check the motor 	See " Checking the cables " on page 35
	Connection loose or faulty or motor faulty		See " Replacing a motor " on page 24
Flashes four times	Fault on l.h. motor.	<ul style="list-style-type: none"> Check the connecting plug Check the motor 	See " Checking the cables " on page 35
	Connection loose or faulty or motor faulty		See " Replacing a motor " on page 24
Flashes five times	Fault/brake fault on r.h. motor. Connection loose or faulty or motor faulty	<ul style="list-style-type: none"> Check the connecting plus 	See " Checking the cables " on page 35 See " Replacing a motor " on page 24

Flashing code:	Significance:	Solution:	Flashing code:
Flashes six times	Fault/brake fault on l.h. motor. Connection loose or faulty or motor faulty	<ul style="list-style-type: none"> Check the connecting plus 	See " Checking the cables " on page 35 See " Replacing a motor " on page 24
Flashes seven times	Battery on low	<ul style="list-style-type: none"> Charge battery 	See instruction manual
Flashes eight times	Battery voltage too high	<ul style="list-style-type: none"> Switch lighting to low battery voltage Check battery charger 	See instruction manual for charger
Flashes nine or ten times	Faulty data transfer between the modules	-	Remove electronic modules with the exception of the main module and the remote. Install the modules one after the other in order to determine which one is causing the disturbance. See " Replacing the Shark Electronics " on page 28
Flashes eleven times	Drive motors overloaded / overheated	<ul style="list-style-type: none"> Switch remote on and off / wait if necessary 	-
Flashes twelve times	Compatibility problems between the modules	<ul style="list-style-type: none"> Remove incorrect module 	See " Replacing the Shark Electronics " on page 28

6.2 Operational faults on a wheelchair fitted with Shark electronics

Please proceed as follows in the event of operational faults:

- First of all analyse the possible cause of the disorder on the basis of the following tables.
- Check the status display on the remote. Analyse the flashing error code.
- Carry out the necessary checks and repairs as recommended in the following table.

6.2.1 Diagnosis of actuation disorders

PROBLEM	OTHER SYMPTOMS	POSSIBLE CAUSE	SOLUTION	DOCUMENTATION
Wheelchair will not start up	Status display on the remote illuminated as normal and does not indicate a disorder code	Actuation motors may be disengaged	<ul style="list-style-type: none"> • Clutch in actuation motors 	See operating instructions
	Status display on the remote is not illuminated	Batteries may be faulty	<ul style="list-style-type: none"> • Replace the batteries 	See " Changing the batteries " on page 31
		Batteries may be almost empty	<ul style="list-style-type: none"> • Charge batteries 	See User Manual
		Power supply to the remote may be interrupted	<ul style="list-style-type: none"> • Check the main fuse 	See " Checking and replacing the main fuse " on page 33
			<ul style="list-style-type: none"> • Check the cable between the modules for any loose connections or damage 	Siehe " Checking the cables " on page 35
		Remote may be faulty	<ul style="list-style-type: none"> • Change the remote on the wheelchair to be able to exclude the remote being the cause of the fault. 	See " Replacing the Shark II Remote " on page 37
	Status display on remote flashing	Various causes	<ul style="list-style-type: none"> • Analyse error code 	See " Shark error codes and diagnostic codes " on page 22

Wheelchair jerky in drive operation	None	Batteries may be faulty (instable voltage)	· Replace the batteries	See " Changing the batteries " on page 31
		Actuation motor(s) may be faulty	· Replace motor(s)	Siehe " Replacing a motor " on page 24
Batteries not being charged	None	Batteries may be faulty	· Replace batteries	See " Changing the batteries " on page 31
	LEDs flashing on charger	Charger may be faulty	· Replace charger	See operating instructions for battery charger
Wheelchair drives too slowly	None	Batteries may be faulty	· Replace batteries	See " Changing the batteries " on page 31

6.2.2 Shark error codes and diagnostic codes

The actuation electronics can automatically remedy certain disorders. In this case the status display will stop flashing. Please switch the remote on and off several times. Please wait about 5 seconds every time before switching the remote on again. If the error is not remedied by this, please diagnose the cause on the basis on the following flashing codes.

FLASHING CODE	Meaning	Solution	FLASHING CODE
1	Operational error	<ul style="list-style-type: none"> Please ensure that the joystick is in neutral central position (simply release joystick) and switch on again. 	
2	Battery error	<ul style="list-style-type: none"> Check battery and power cable. 	See "Checking the cables" on page 35
		<ul style="list-style-type: none"> Charge batteries. If you switch the wheelchair off for a few minutes the batteries are often able to re-charge sufficiently to enable a short journey. You should, however, only use this solution in an emergency as this leads to the batteries discharging excessively. 	See operating instructions
		<ul style="list-style-type: none"> Replace the batteries 	See "Changing the batteries" on page 31
3	Error on the left motor (M2)	<ul style="list-style-type: none"> Check the motor cable and U-connector. Check the motor. 	See "Checking the cables" on page 35 See "Replacing a motor" on page 24
4	Error on the right motor (M1)	<ul style="list-style-type: none"> Check the motor cable and U-connector. Check the motor. 	See "Checking the cables" on page 35 See "Replacing a motor" on page 24
5	Fault on the left (M2) motor brake	<ul style="list-style-type: none"> Check cable and connector. 	See "Checking the cables" on page 35
6	Fault on the right (M1) motor brake	<ul style="list-style-type: none"> Check cable and connector. 	See "Checking the cables" on page 35
7	Fault on the Shark remote	<ul style="list-style-type: none"> Check the bus cable on the remote and U-connector. Replace the remote. 	See "Checking the cables" on page 35 See "Replacing the Shark II Remote" on page 37

FLASHING CODE	Meaning	Solution	FLASHING CODE
8	Fault on Shark main module	<ul style="list-style-type: none"> Check all cables and connectors on the Shark system. Replace the main module. 	<p>See "Checking the cables" on page 35</p> <p>See "Replacing the Shark Electronics" on page 28</p>
9	Communication error on the Shark system	<ul style="list-style-type: none"> Check all cables and connectors on the Shark system. Replace the remote. 	<p>See "Checking the cables" on page 35</p> <p>See "Replacing the Shark II Remote" on page 37</p>
10	Unknown error	<ul style="list-style-type: none"> Check all cables and U-connectors. 	<p>See "Checking the cables" on page 35</p>
11	Incompatible remote	<ul style="list-style-type: none"> An incorrect remote has been connected. Ensure that main module and remote code are concordant. 	<p>See "Replacing the Shark II Remote" on page 37</p> <p>See "Replacing the Shark Electronics" on page 28</p>

7 Repair Work

7.1 General warning information on installation work



CAUTION: Risk of damage to the vehicle! Collisions can be caused if shim rings are removed from the drive wheels during installation work!

- Shim rings are frequently placed between the drive shaft and the wheel hub to compensate tolerances. Collisions can be caused if these shim rings are removed and not re-installed! Please install all shim rings in exactly the same positions they were in before dismantling.

7.2 Replacing a motor



PLEASE NOTE: Danger of tipping and crushing

- When jacking up the wheelchair please use a block of wood that is large enough to provide large-area support to the wheelchair under the battery box. This improves the tilt resistance of the wheelchair during repair work.



PLEASE NOTE: Fire hazard and danger of burns due to bridging of the battery poles

- When replacing the batteries the battery poles must NOT come into contact with the metal parts of the wheelchair thus leading to bridging.
- Please be sure to re-apply the battery pole caps after the batteries have been replaced.



Pre-requisites:

- Small, flat screwdriver
- 5 mm Allen key
- 8 mm Allen key
- 11 mm open-ended spanner
- 19 mm open-ended spanner
- Metal pin, 2.5 mm in diameter (for striking out the splint in the disengaging lever)
- Small hammer
- Edge cutter
- Cable tie
- Block of wood (approx. 12 x 12 x 30 cm) to jack up the vehicle



Information

Please keep small parts such as screws and grommets safe during dismantling. Lay all small parts down in such a way that they can be re-fitted in the correct order.

- Remove the battery cover.



- Pull off and push back the battery pole caps in order to access the battery poles.
- Release the battery pole clamps (1) using the 11 mm open-ended spanner.

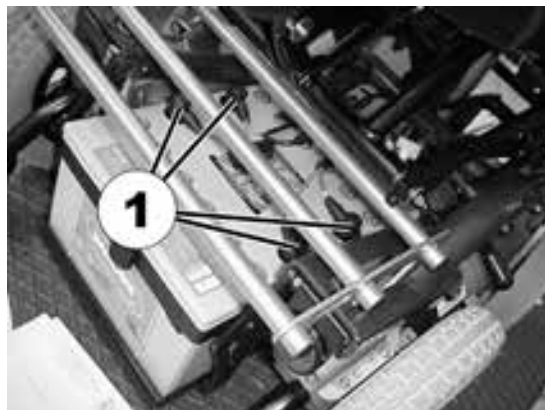

- Pull out the batteries.

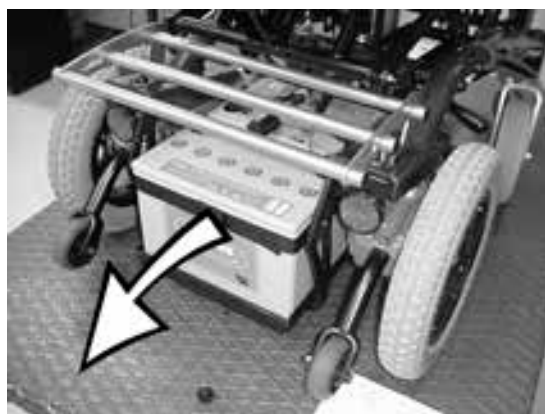

- Use the block of wood to jack up the vehicle.
- Use the 5 mm Allen key to loosen the Allen head screw (1).
- Remove the screw and the wheel rim.
- Remove the complete wheel from the wheel hub.



- The front release bar connection (1) must be released in order to remove the motor. Use the small, flat screwdriver to loosen the retaining clip (1) and pull out.

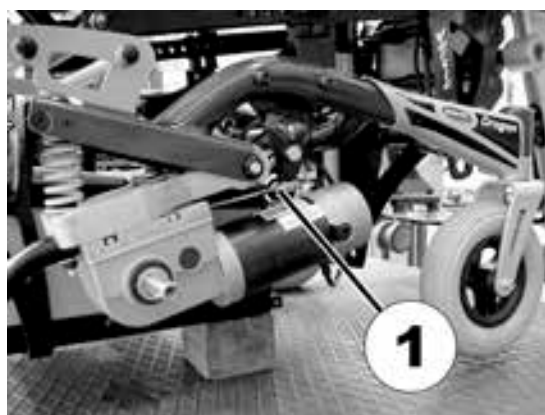

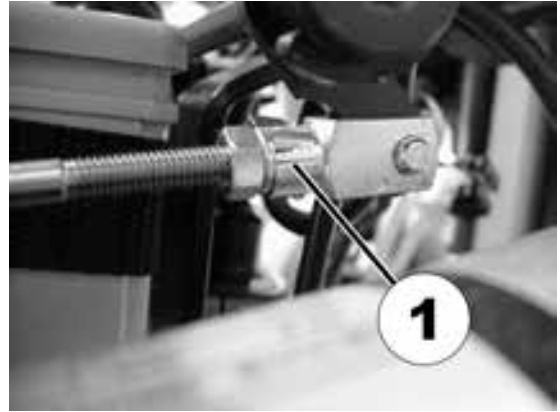

- Unscrew the hand wheels (screws) (1) on both sides of the electronic system panelling.
- Remove the electronic system panelling.



- Remove the motor plug (1) on the motor to be replaced from the electronic system.
- The motor cable is fastened to the frame by means of a cable tie. Cut through the cable tie using the edge cutter.



- Use the 8 mm Allen key and the 19 mm open-ended spanner to release the motor mounting (1) and remove.
- Remove the motor from the mounting in a downward direction.

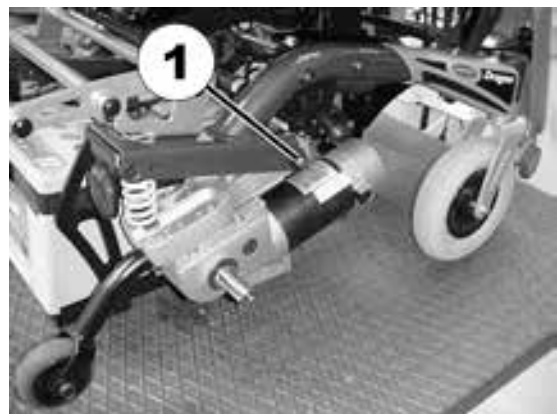

- Loosen and remove the four screws (1) on the motor mounting.

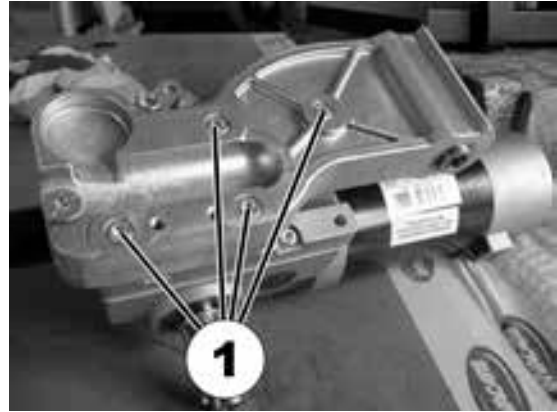

- Use the metal pin and the hammer to carefully knock the splint (2) out of the release lever (1).
- Pull the release lever (1) together with the release bar from the old motor (cannot be seen in the picture on the right).

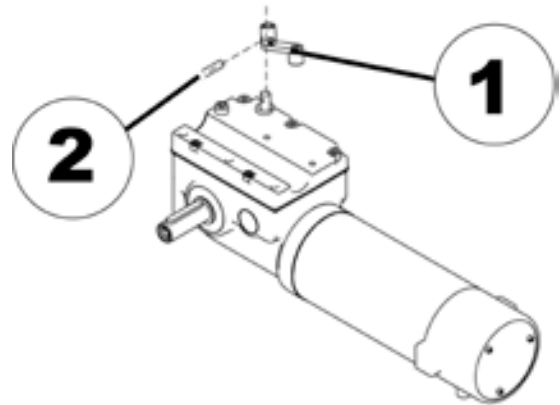

PLEASE NOTE: Motor damage possible

- Only press the release lever lightly onto the metal bar on the new motor. Do not use a hammer for this purpose.



Information

It is easiest to fit the release lever before the motor is screwed onto other parts.

- Carefully press the release lever (1) onto the rod (2) protruding from the new motor.
- Press the splint (3) in.

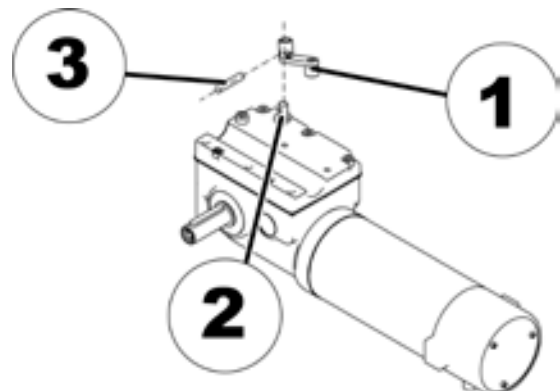

- Further assembly of the motor is carried out in reverse order to disassembly.
- Secure the motor cable using a new cable tie.

7.3 Replacing the Shark Electronics



Pre-requisites:

- Phillips screwdriver
- To modify a drive programme you will need: Programming software or a Handheld Programmer and the Installation Manual of the Shark Electronics (Part Number 1436160), available from Invacare®.



NOTE

All electronic modules are supplied with a standard drive programme. If the driving programme has been customised, then you will have to perform this customisation again, after installing the new electronic module.



WARNING: Every alteration to the drive programme can influence vehicle handling and the tipping stability of the wheelchair!

- *Alterations to the drive programme must only be carried out by trained Invacare®-dealers!*
- *Invacare® can only assume a warranty for the safe vehicle handling of the wheelchair – in particular tipping stability - for unaltered standard drive programmes!*

- Unscrew the handwheels (screws) (1) on both sides of the panelling for the electronics.
- Remove the electronic panelling.



- Disengage all the plugs (1) on the electronic module.

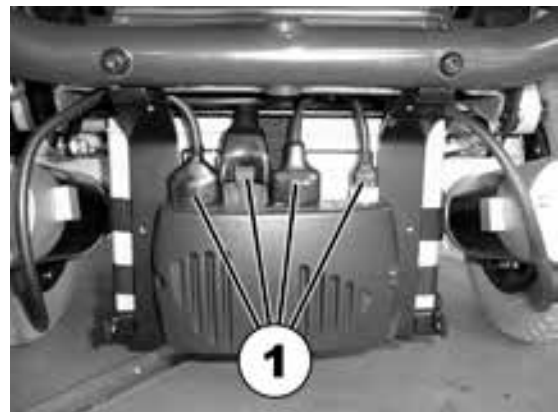

- Remove the screws (1) on both sides of the power module.
- Pull out the module.

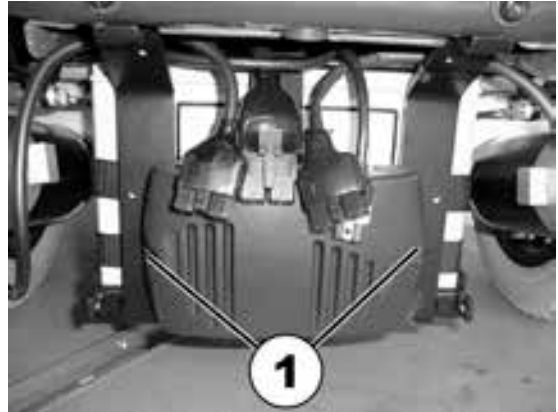

- Installation of the electronics is carried out in the reverse order.
- Update the software, in case a newer version is available.
- Customise the driving programme with the programming software, if required.
- Check all vehicle functions.

7.4 Updating the driving program

The driving programs for electric wheelchairs are continually updated and improved by Invacare®. For this reason, you should check whether the version number is still up to date each time a wheelchair comes in for repairs, and also during regular inspections.

If a newer version is available, the driving program must be updated. The procedure for updating the driving program is described in the user manual of the Wizard software.



NOTE

The electronic system is supplied with a standard drive program. If the driving program has been customised, you have to perform this customisation again, after installing the new driving program.



WARNING: Every alteration to the drive program can influence vehicle handling and the tipping stability of the wheelchair!

- *Alterations to the drive program must only be carried out by trained Invacare®-dealers!*
 - *Invacare® can only assume a warranty for the safe vehicle handling of the wheelchair – in particular tipping stability - for unaltered standard drive programs!*
-



Pre-requisites:

- Dynamic® Wizard software
 - User manual for the Wizard software
 - For further information on other requirements - such as the minimum system configuration of the PC to be used for programming, necessary programming cables - see the user manual of the Wizard software. You find the latest version of the user manual in the download area on <http://www.dynamiccontrols.com/>.
-

7.5 Changing the batteries



CAUTION:

Risk of injury if the batteries are not handled appropriately during installation and maintenance work!

- Installation of new batteries should only be carried out by authorised, qualified personnel.
- Please observe the warning signs on the batteries.
- Please give consideration to the great weight of the batteries.
- Only use the types of batteries shown in the technical data.

Risk of fire and burns due to bridging the battery poles!

- Do NOT bridge the battery poles with a tool!



WARNING:

Corrosion and burns from acid leakage if batteries are damaged!

- Remove clothes that have been soiled by acid immediately!

After contact with skin:

- Immediately wash affected area with lots of water!

After contact with eyes:

- Immediately rinse eyes under running water for several minutes; consult a physician!

7.5.1 Removing the batteries



CAUTION: Risk of fire and burns if battery poles are bridged!

- When replacing the batteries the battery poles MUST NOT come into contact with metal parts of the wheelchair causing bridging.
- Be sure to replace the battery pole caps after the batteries have been replaced.



Requirements:

- Open-end spanner 11 mm

- Remove the battery cover.



- Pull the battery pole caps (1) upward and push back in order to reach the battery poles.
- Use the open-ended spanner to loosen the battery pole clamps.
- If your powerchair is equipped with ACS Electronics, you will need to lift the device support in the rear (fastened with Velcro strips).
- Remove the batteries to the rear.

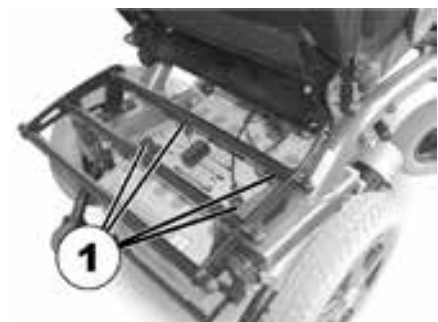

7.5.2 How to handle damaged batteries correctly

**WARNING:****Corrosion and burns from acid leakage if batteries are damaged!**

- *Remove clothes that have been soiled by acid immediately!*

After contact with skin:

- *Immediately wash affected area with lots of water!*

After contact with eyes:

- *Immediately rinse eyes under running water for several minutes; consult a physician!*
-

**Requirements:**

- Safety goggles
 - Acid-resistant gloves
 - Acid-resistant receptacle for transportation
-

- Always wear appropriate safety clothing when handling damaged batteries.
- Place damaged batteries in an acid-resistant receptacle immediately after removing them.
- Only ever transport damaged batteries in an appropriate acid-resistant receptacle.
- Wash all objects that have come into contact with acid with lots of water.

Disposing of dead or damaged batteries correctly

Dead or damaged batteries can be given back to your dealer or directly to Invacare®.

7.6 Checking and replacing the main fuse



CAUTION! Fire hazard!

- Always use an original strip fuse with approved current.
- If the main fuse has blown, remedy the cause before a new fuse is installed.



WARNING: Danger of fire exists if the fuse is incorrectly assembled!

- Only ever assemble the fuse in the order shown in the illustration at right!
- Always tighten nuts to between 3.3 and 3.5 Nm!

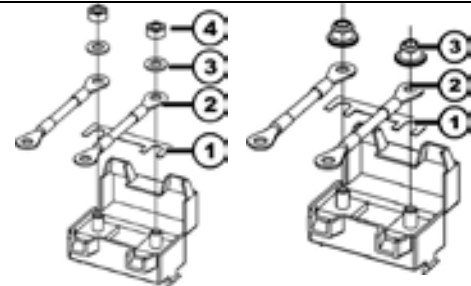

Until 03.2004

1. Fuse
2. Fuse compartment
3. Washer
4. Nut M5

After 03.2004

1. Fuse
2. Fuse compartment
3. Nut DIN 6923



Pre-requisites:

- 8mm open-ended spanner
- 40A strip fuse



Information

If the fuse holder is damaged this can be replaced completely together with the battery cables.

- Remove the battery cover.



- If your powerchair is equipped with the Shark Electronic System, then the fuse holder is located on top of the batteries (1), if you have ACS Electronics, then it is located on the device support.
- Open the fuse holder cover.
- If the strip fuse has blown, determine the cause of the fault and remedy if necessary. The main fuse should only be replaced when the fault has been remedied.

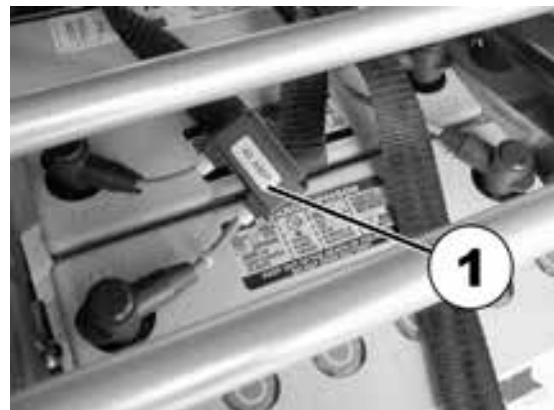

- Use the 8mm open-ended spanner to unscrew the nuts (2) on the strip fuse.
- Replace the strip fuse.



- Installation is carried out in the reverse order.
- Check all vehicle functions.

7.7 Checking the cables

- Unscrew the handwheels (screws) (1) on both sides of the panelling for the electronics.
- Remove the panelling for the electronics.



- Check all cables for visible damage and crushing. Replace damaged cables.
- Pull on each plug (1) carefully. It must not come out of the socket.
- If a plug is loose, apply slight pressure to push the plug into the socket. It must lock in place.
- Check whether the plug is now fitted firmly inside the socket. If not, please repeat the preceding work step.



- Remove the battery cover.



- Check the battery cables (1) for visible damage and crushing. Replace damaged cables.



- Re-install the panelling for the electronics and the battery cover.
- Check all vehicle functions.

7.8 Replacing the Shark II Remote



Pre-requisites:

- Screwdriver for recessed head screws

- Shut down the remote.
- Pull the plug (1) out to the rear.
- Release the wing screw (2).
- Pull the remote and the remote holder out of the guide device.



- Use the screwdriver to remove the screws (1) on the remote holder.

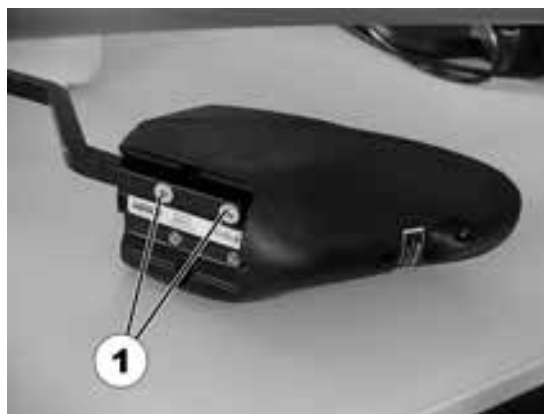

- Remote assembly is carried out in the reverse order.
- Check all vehicle functions.

7.9 Replacing the ACS Remote



Pre-requisites:

- Phillips screwdriver
- To modify a drive programme you will need: Programming software or a Handheld Programmer and the Installation Manual of the ACS Electronics, available from Invacare®.



NOTE

All ACS remotes are supplied with a standard drive programme. If the driving programme has been customised, then you will have to perform this customisation again, after installing the new electronic module.



WARNING: Every alteration to the drive programme can influence vehicle handling and the tipping stability of the wheelchair!

- *Alterations to the drive programme must only be carried out by trained Invacare®-dealers!*
- *Invacare® can only assume a warranty for the safe vehicle handling of the wheelchair – in particular tipping stability - for unaltered standard drive programmes!*

- Switch off the remote.
- Pull the bus cable (1) out of the remote.
- Loosen the thumb screw (2).
- Pull the remote and the remote holder out of the guiding device.

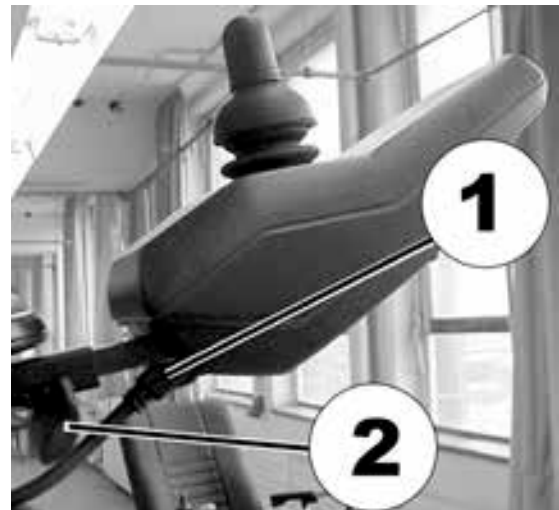

- Unscrew both remote holder screws (1) using the crosstip screwdriver.



- Installation of the remote is carried out in reverse order.
- Update the software, in case a newer version is available.
- Customise the driving programme with the programming software, if required.
- Check all vehicle functions.

7.10 Replacing the steering head bearings on the steering wheels



CAUTION! Incorrect installation can damage the bearings and lead to the steering wheels falling off!

- *The single-row angular ball bearing rings are not identical on both sides. This is why there is only one correct way of fastening them. The assembly instructions must, therefore, be followed exactly.*



Required parts/tools:

- 19 mm socket wrench
- Torque spanner
- Large screwdriver, flat
- Wooden chock (approx. 12 x 12 x 30 cm) for jacking up the vehicle

- Use the wooden chock (1) to jack up the wheelchair on the side on which the ball bearings are to be replaced.

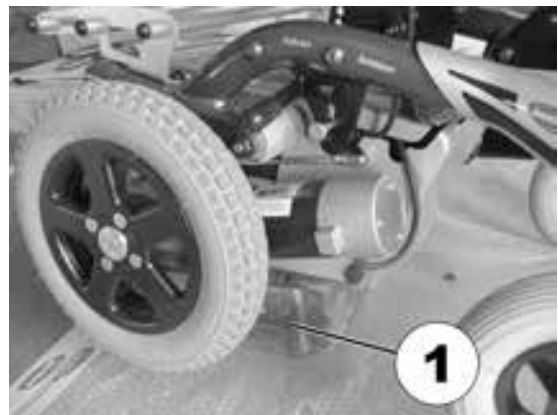

- Carefully remove the plastic cap (1) using the large screwdriver.



- Use the socket wrench to loosen and remove the 19 mm nut. Hold the wheel in such a way that it is not able to rotate when the nut is removed.
- Pull the steering head shaft downward and out of the steering head tube.
- Remove the shim and the ball race from the head of the tube. The other ball race should be on the shaft.

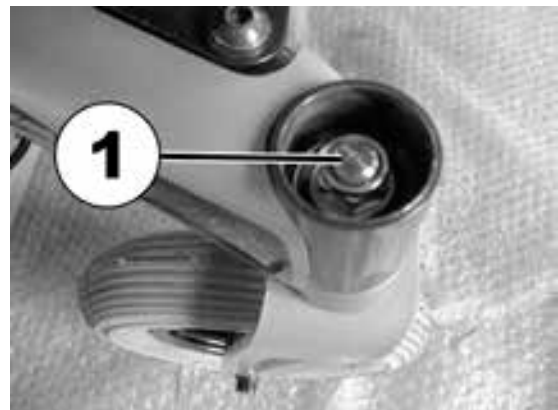

IMPORTANT ASSEMBLY INFORMATION!

The illustrations show the wide edge on the outside of the ball race (A) and the narrow edge on the inside (B).

The bearings must always be installed in such a way that the narrow edges are facing each other (inside). The steering head bolt and the nut must always press against the wide outside edges. The bearings would otherwise be pressed apart by the bolt pressure.

The steering wheels should be able to rotate freely after assembly, but there must not be any clearance on the bearings.

- Tighten the nut primarily to 20 Nm +/- 2 Nm.
- Slacken the nut slightly.
- Re-tighten to 15 Nm +/- 1.5 Nm.



7.11 Repairing a flat tyre



CAUTION: Risk of injury if the vehicle unintentionally goes into motion during repair work!

- Shut down the power supply (ON/OFF button)!
- Clutch in the actuator!
- Secure the vehicle before jacking it up by blocking the wheels with wheel chocks!

7.11.1 Repairing the flat tyre (pneumatic tyre equipment type 12½ x 2¼")



Pre-requisites:

- 5 mm hexagon socket wrench.
- Repair kit for inner tube tyres **or** a new inner tube.
- Talcum powder

Dismantling the wheel

- Jack up the vehicle (place a wooden wedge under the frame).
- Unscrew the countersunk screw (1).
- Remove the wheel from the axle.



PLEASE NOTE

Installation is carried out in reverse order. Please ensure that the wheel is re-fitted on the same side and in the same running direction as removed.

Repairing the flat tyre

- Unscrew the valve cap.
- Exhaust the air from the tyre by pressing the spring pin in the valve.
- Unscrew 5 cylinder head bolts (reverse side of the wheel, 2).
- Remove the rim halves from the shoe.
- Remove the inner tube from the tyre.
- Repair the tube and re-fit or fit new tube

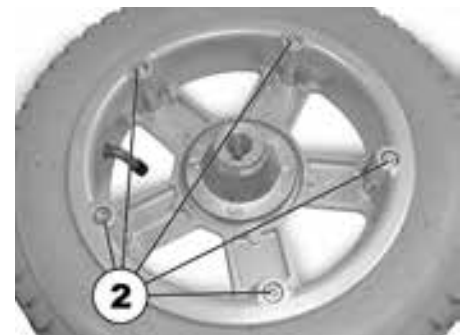

PLEASE NOTE

If the old tube is to be repaired and re-fitted and has become wet during repair work, powdering the hose with some talcum powder can simplify the fitting procedure.

- Re-insert the rim halves into the tyre from the outside.
- Inflate the inner tube slightly with air.
- Re-apply the cylinder head bolts and screw rim together tightly.
- Check the exact fit of the shoe.
- Inflate the tyre to the prescribed air pressure.
- Re-check the exact fit of the shoe.
- Screw on the valve cap.
- Re-install the wheel.

7.11.2 Repairing a flat tyre (pneumatic tyre equipment type 220/120 x 50)



Pre-requisites:

- 6 mm Allen key
- 13 mm open-ended spanner
- 2 x small ring spanners or flat screwdrivers (for removing the shoe)
- Repair kit for inner tube tyres **or** a new inner tube
- Talcum powder

Removing the wheel

- Jack up the vehicle (place a wooden wedge under the frame).
- Loosen and remove the screw (1) using the Allen key on one side and the open-ended spanner on the other side (for countering).
- Pull the wheel from the fork



PLEASE NOTE

Installation is carried out in reverse order. Please ensure that the wheel is re-fitted on the same side and in the same running direction as removed.

Repairing a flat tyre

- Unscrew the valve cap.
- Exhaust the air from the tyre by pressing the spring pin in the valve.
- Use the flat screwdrivers or other tools to carefully remove the shoe from the rim. Do not damage the tube if this is to be used again.
- Repair the tube and re-fit or fit new tube.



**PLEASE NOTE**

If the old tube is to be repaired and re-fitted and has become wet during repair work, powdering the hose with some talcum powder can simplify the fitting procedure.

- Re-apply the shoe.
- Check the exact fit of the shoe.
- Inflate the tyre to the prescribed air pressure.
- Re-check the exact fit of the shoe.
- Screw on the valve cap.
- Re-install the wheel.

7.12 Replacing a drive wheel



CAUTION! Danger of the wheelchair tipping over or rolling away!

- Prevent the wheelchair tipping over by jacking it up on a wooden chock that is long and wide enough and placing this underneath the battery box. If the wooden chock is too short or too high this can lead to the wheelchair tipping over.
- Switch the wheelchair off on the remote.



Required parts/tools:

- 5 mm Allen key
- Wooden chock (approx. 12 x 12 x 30 cm) for jacking up the vehicle.



Information

Please take care of the small parts and observe the sequence in which the component parts are installed. Please set them out in an orderly fashion so that they can be installed again easily in the correct sequence.

- Jack up the vehicle using the wooden chock (1).

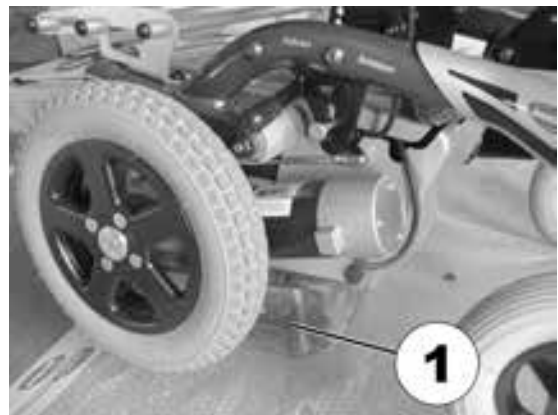

- Loosen the 4 screws fastening the wheel (1) using the 5mm Allen key.
- Remove the wheel from the hub.



- Installation is carried out in the reverse order.

7.13 Checking a regulating motor

**Parts/tools required:**

- Multimeter

- The electric resistance of the regulating motor is to be checked at the connection assembly. In case this is close to infinite, the motor is probably burnt out. If it is less than 1W, the motor has short-circuited. In either case the motor must be replaced.



7.14 Replacing the verticalizer actuator

**Pre-requisites:**

- Screwdriver, flat, width of edge approx. 6 mm

- Raise the actuator. The actuator retaining pins are to be found at (1) and (2).

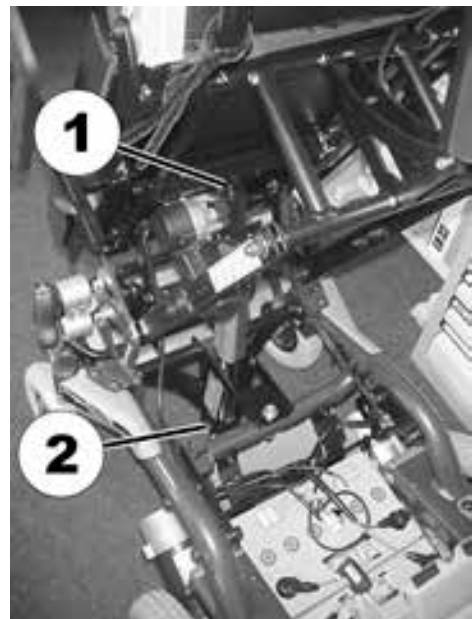

- Remove the battery cover.
- Cut through the cable tie (A).
- Remove the actuator cable connector from the electronic system.

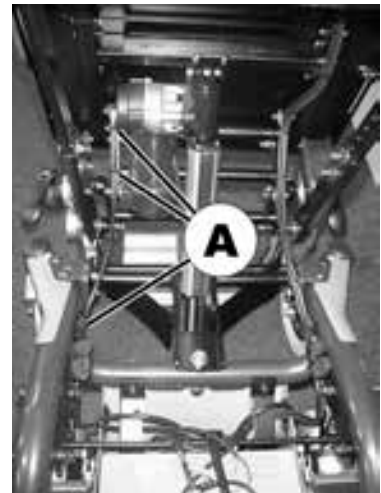

- Arrange for a second person to support the verticalizer.
- Remove the security lock locking device of the upper retaining pin (1).
- Remove the retaining pin.



- Remove the security lock locking device of the lower retaining pin (2).
- The actuator retaining pins are to be found at (1) and (2).



- Pull out the actuator.
- Insert the new actuator.
- Re-apply the retaining pins and security lock locking devices.
- Secure the actuator cable using new cable ties.
- Check all functions of the verticalizer.

7.15 Replacing the safety belt

**Requirements:**

- 10 mm socket spanner
- 4 mm Allen key

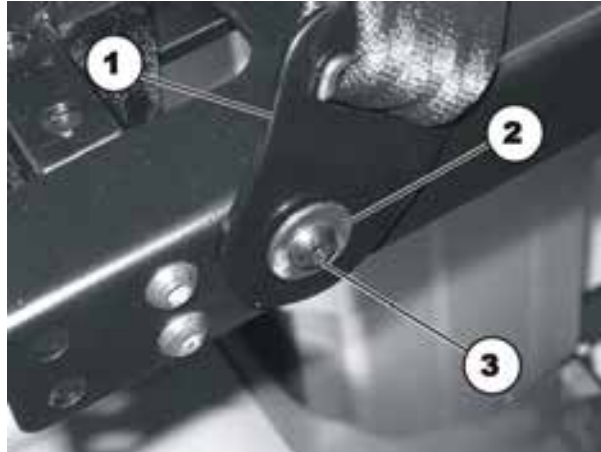
**Dismantling the safety belt:**

- Remove the plastic cap (5).
- Loosen the bolt (3) and the associated nut (in the figure this is covered) with a 4 mm Allen key and a 10 mm socket spanner.
- Remove the nut incl. the washer.
- Remove the screw incl. the safety belt, the washer (2) and the washer arranged behind.

**Note**

Another nut is fixed between the two washers (2) and (4) as a spacer so that the belt mounting can rotate freely.

- Replace the safety belt (1).

Refitting the safety belt:

- Refit the parts in reverse order.

7.16 Chest strap

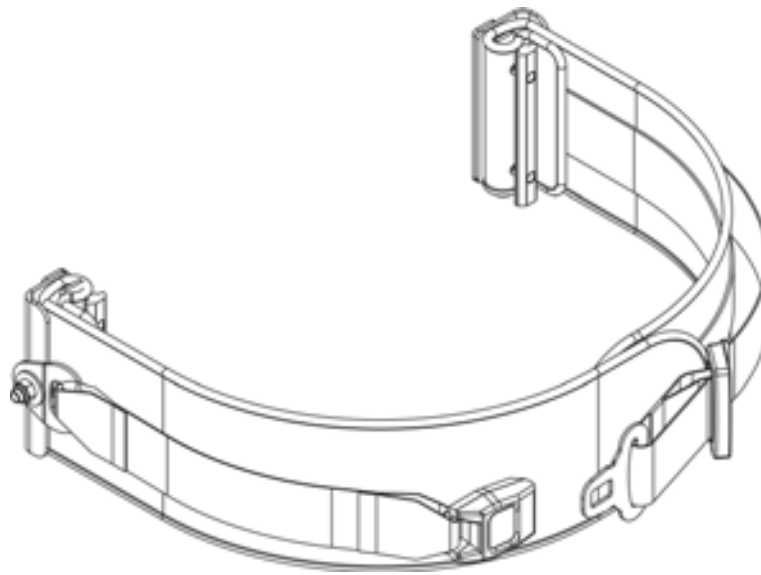

7.16.1 Replacing the chest strap



Requirements:

- 5 mm Allen wrench

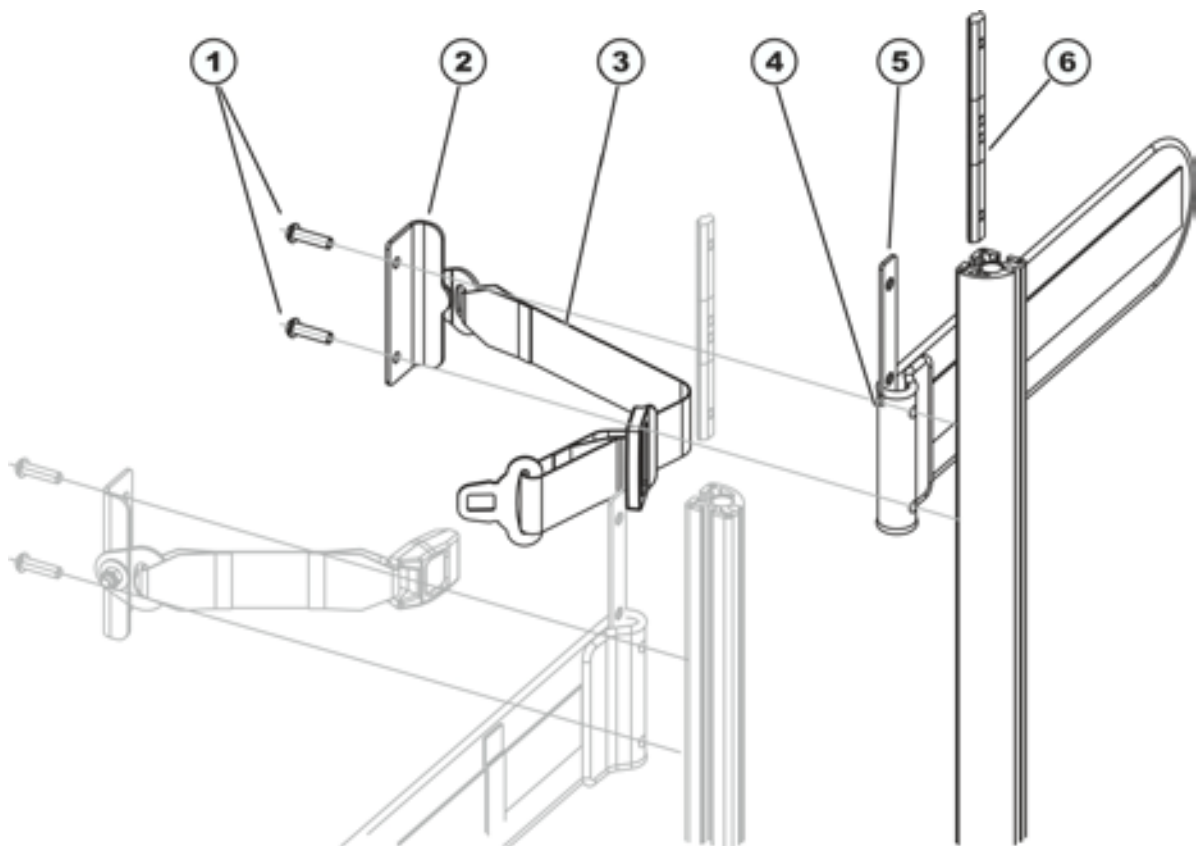

Uninstalling the chest strap:

- Loosen and remove the hexagon socket head screws (1) together with the washers.
- Remove the mounting plate (2) of the additional belt (3).
- Remove the chest strap (4). Pay attention to the insert (5) while doing this.

Installing the chest strap:

- Place the insert into the chest strap.
- Position the mounting plate of the additional belt.
- Install the hexagon socket head screws with the washers. These have to go through the holes provided in the components, and are screwed into the sliding block (6).
- Set the height of the chest strap approximately to the desired height and tighten the Allen screws.
- Set the exact height of the chest strap later together with the user, see Chapter 8.6.

7.16.2 Replacing the additional belt**Requirements:**

- 13 mm socket wrench

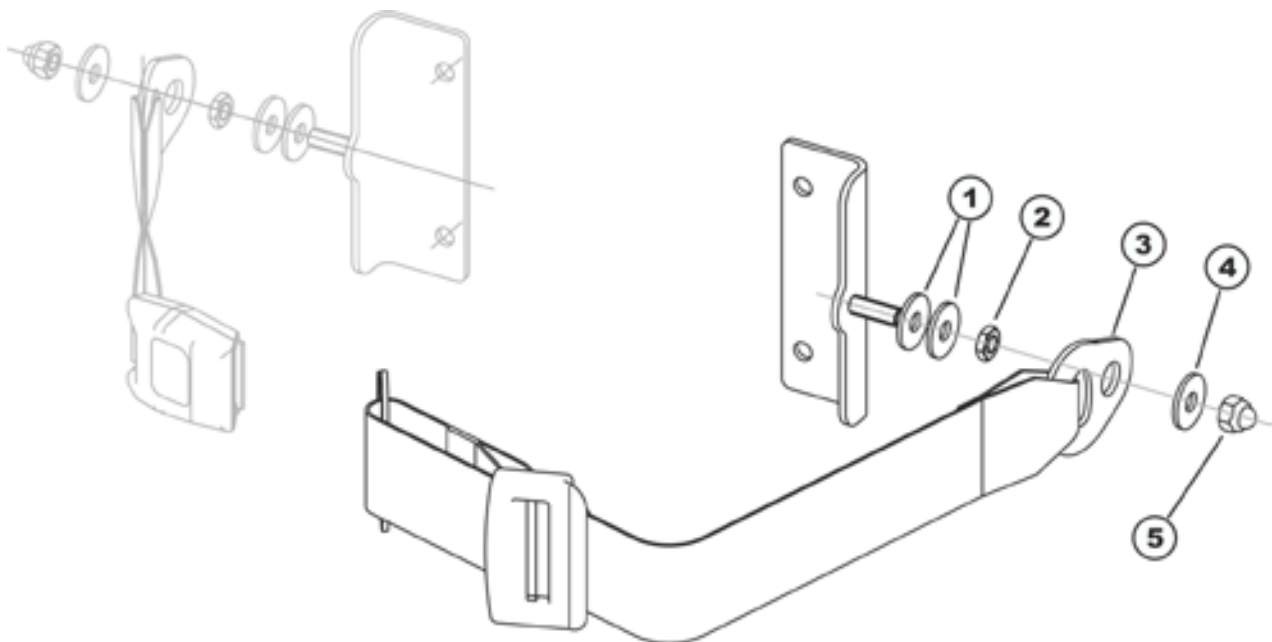
**Uninstalling the additional belt:**

- Loosen and remove the box nut (5) together with the washer (4).
- Remove the attachment bracket (3) of the additional belt.

**Note**

It is not necessary to remove the nut (2) and the washers (1). These are mounted as spacers so that the belt attachment bracket can rotate freely.

Installing the additional belt:

- Assemble the parts in reverse order.

8 Adjusting the wheelchair to the user's seating posture

The alignment of the verticalizer and the seat position of the user should be carried out in the following order:

1. Seat depth
2. Lower leg length
3. Back height
4. Knee cushion distance to shin
5. Knee cushion height
6. Distance between the knee cushions
7. Armrest height
8. Armrest angle
9. Chest belt height
10. Backrest angle
11. Headrest
12. Stand-up angle

8.1 Adjusting the seat depth

To optimally adjust the wheelchair to the user's needs, it is advisable to have the seat depth adjusted individually by an authorised Invacare® dealer.

There are perforated rails under the seat for adjusting the seat depth. This results in the following seat depths: 38, 40, 42, 44 and 46 cm. These values are etched into the lower perforated rails as a positioning guide. The electric wheelchair is set at the max. seat depth of 46 cm when supplied.



CAUTION! Danger of injury

- *When carrying out work underneath the raised seat unit it must be ensured that this is not lowered. The electric wheelchair must be switched off.*



CAUTION! If the seat depth is not adjusted properly, there is danger of the verticalizer being destroyed!

- *The lower and upper perforated rails of the parallelogram must be adjusted in an analog fashion towards each other. In the event of diversity in adjustment the verticalizer is destroyed upon operation due to the change in geometry.*



What should be observed when adjusting the seat depth?

If the seat depth adjustment is too short, the forces on the body whilst standing up are too great. If the seat depth adjustment is too long, the user can "collapse" whilst standing up.



Pre-requisites:

- 4 mm Allen key
- 6 mm Allen key
- 13 mm open-ended spanner

The picture on the right shows the position of the seat plate guide screws (1) and the fastening screws of the perforated rails (2).



- Loosen the seat plate guide screw (1).
- Loosen the fastening screws of the perforated rails (2) using an Allen key and an open-ended spanner and pull out.
- Adjust the perforated rails to the desired seat depth.
- Screw the screws back in and tighten using an Allen key and an open-ended spanner.

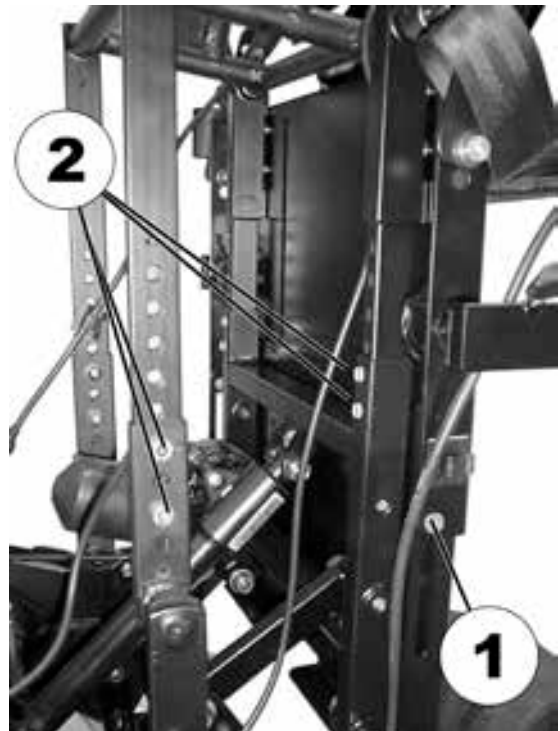

8.2 Legrest

8.2.1 Setting the lower leg length of the legrest

**The adjustment range of the calf length depends on the seat height!**

Depending on the model, the calf length has two possible adjustment ranges (measured including the seat cushion):

- 36...45 cm
- 41...50 cm

**What should be observed when adjusting the lower leg length?**

When adjusting the lower leg length, please make sure that the legrests are individually adjusted to correctly fit the length of the user's legs. The thighs must be resting on the seat cushion.

**Pre-requisites:**

- 5 mm Allen key

- Loosen the screws (1) using the Allen key.
- Set the foot plate to the desired height.
- Re-tighten the screws.

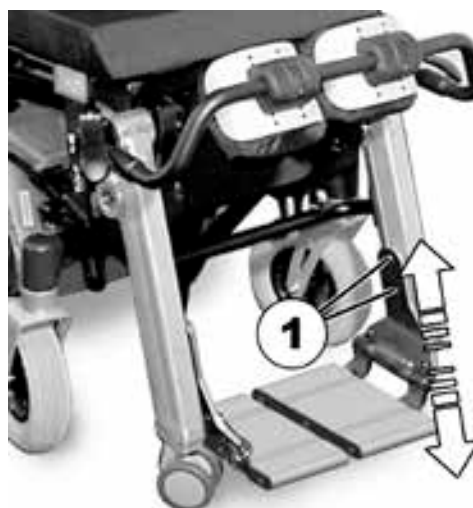

8.3 Changing the height of the backrest

By cutting off a segment of the backrest sling (underneath the backrest cushion), the height of the backrest can be permanently shortened once by 5 cm.



Requirements:

- Allen key 3 mm
 - Scissors
-

- Remove seat cushion.



- Remove backrest cushion.



To change the height of the backrest, first the covers (A) on the ends of the backrest support tubes need to be loosened.

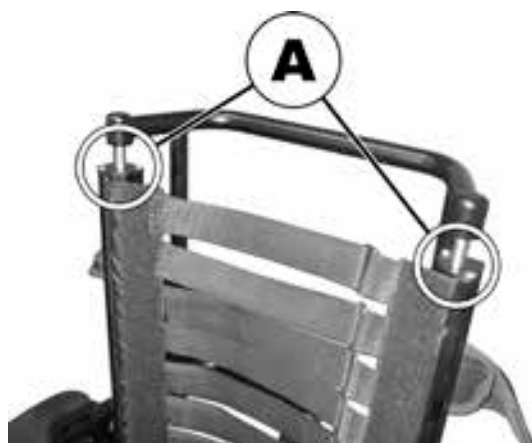

- Loosen and remove the screws (1) that hold the covers, using the 3 mm Allen key.



- Turn each cover so that the gap (1) is pointing towards the front, positioned directly over the end of the fixation rod of the backrest sling.



- Pull the backrest sling up through the opening.



- Using the scissors, cut the last segment of the backrest sling off, as shown in the illustration.



- Push the backrest sling and, if necessary, the fixation rod back down into the backrest frame.



- Re-position the screws (1) in the covers on the ends of the backrest frame tubes and tighten with the Allen key.



8.4 Restraining straps for the legs

8.4.1 Opening and closing the restraining strap

- Flip lever (1) over. The restraining bar is released.
- Open the restraining strap (2) to the front.
- If necessary, loosen the locking lever on the other side and remove the entire strap.
- The restraining strap is re-fitted in the reverse order and closed.



8.4.2 Adjusting the position of the release lever



WARNING: Danger of injury, in case one of the fixation bolts loosens or falls out, as a result of incorrect assembly!

- *The lower nut on the fixation bolt must always be tightened to 15 Nm after all assembly work!*



Requirements:

- Open-end spanner 13 mm
- Torque spanner 13 mm

- Loosen the fixation nut (1) of the release lever.
- Adjust the lever to the desired position.
- Re-tighten the nut to 15 Nm.



8.4.3 Adjusting the retaining bar and knee cushions

8.4.3.1 Setting the depth of the restraining strap

**Pre-requisites:**

- 5 mm Allen key

**What should be observed when adjusting the distance of the knee cushion to the shin?**

If the distance of the knee cushion to the shin is too small, great pressure is asserted on the legs when standing up. If the distance is too large, the user can “collapse” whilst standing up.

The holes in the inner and outer tubes are spaced differently. The many possible combinations of holes provide the ability to finely adjust the retaining bar.

- Use the screw wrench to loosen the Allen screws (1) and remove.
- Set the desired knee strap position (choose hole pattern combination inner tube/outer tube).
- Replace the screws and tighten.



8.4.3.2 Adjusting the height of the knee cushions



Pre-requisites:

- Crosstip screwdriver



WARNING: Danger of injury!

- *The knee pads should not press directly on the knees! The upper edge of the knee pads should be positioned just below the upper end of the shin bone!*

- Remove the knee cushion upholstery.



- Loosen the screws (1) using the crosstip screwdriver and remove.



- Move the knee cushions to the desired position.
- Re-insert the screws and tighten.



8.4.3.3 Setting the width of the knee cushions

**Pre-requisites:**

- 4 mm Allen key
-
- Use the screw wrench to loosen the Allen screws (1).
 - Set the desired knee cushion position.
 - Re-tighten the screws.



8.5 Adjusting the armrests and the control panel

8.5.1 Adapting the height of the armrests



Pre-requisites:

- 5 mm Allen key

- Loosen the eight Allen screws (1) (only the four on the right side are to be seen in the picture).
- Adjust the height of the armrests.
- Re-tighten the screws.

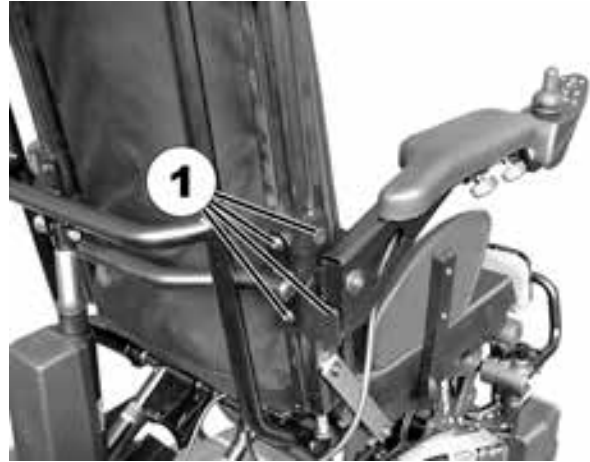

8.5.2 Setting the angle of the swing-up armrest



Pre-requisites:

- 5 mm Allen key
- 13 mm open-ended spanner



WARNING: Damage to the wheelchair may result if the height of armrests is unevenly adjusted!

- *The armrests should only ever be adjusted parallel to each other, never higher on one side and lower on the other!*

- Use the open-ended spanner to loosen the counternut (1).
- Adjust the Allen screw (2) until the desired setting angle of the armrest has been achieved.
- Re-tighten the counternut (1).



8.5.3 Setting the resistance of the swing-up armrest

The swing-up armrest is prevented from lowering under its own weight by the pre-set resistance.

**Pre-requisites:**

- 5 mm Allen key
- Adjust the Allen screw (1) until the desired resistance of the armrest has been achieved.



8.5.4 Adapting the control panel to the length of the user's arm

- Loosen the wing screw (1).
- Set the remote to the desired length by pushing forward or backward.
- Re-tighten the screw.



8.5.5 Setting the height of the remote

- Loosen the wing screw (1).
- Set the remote to the desired height.
- Re-tighten the screw.



8.5.6 Adjusting the width of the armrests

The distance between the side sections can be adjusted by 5.5 cm on both sides (11 cm in total).



Requirements:

- Allen key 8 mm

Where to find the adjustment screws

The picture shows the position of the screws (1) (underneath the seat frame, hidden in the picture), that allow an adjustment to the width of the side sections.



Doing the adjustment

- Loosen the screw (1).
- Set the side section in the desired position.
- Re-tighten the screw.
- Check the firm fit of the side section.
- Repeat the process for the second side section.

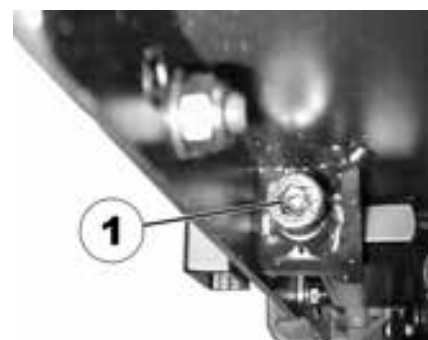

8.6 Adapting the height of the chest belt

**Pre-requisites:**

- 5 mm Allen key

**WARNING: Risk of falling if the chest strap is not closed!**

- *Make sure that the Velcro strips on the chest strap cover each other completely!*
- *Always secure the chest strap with the additional belt (with the latch), before the chair is raised up.*

**What should be observed when adjusting the height of the chest belt?**

The height of the chest belt depends on the stability of the upper part of the body. The lesser the stability, the higher the belt adjustment.

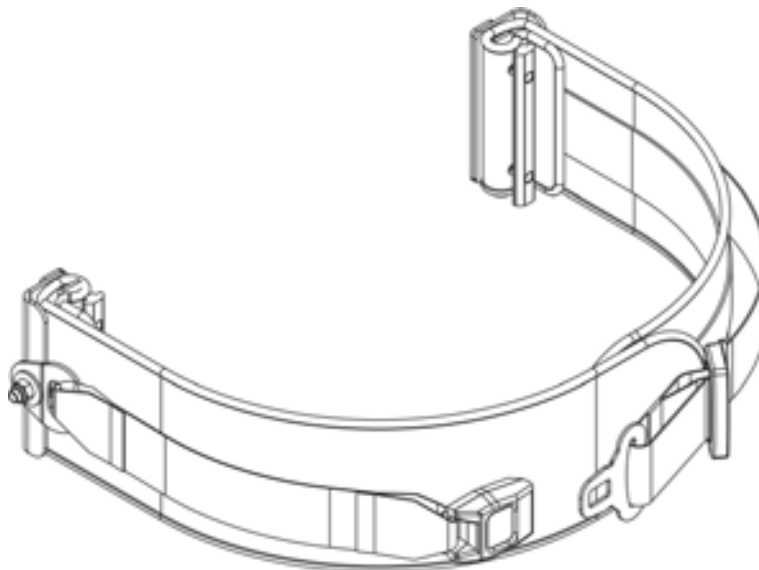

- Loosen the Allen screws (1).
- Adjust the height of the belt.
- Re-tighten the screws.



8.7 Adjusting the headrest

8.7.1 Adjusting the height

- Loosen the hand wheel (1).
- Move the headrest to the desired height.
- Re-tighten the hand wheel.



8.7.2 Setting the position

- Loosen the release handle (1,2 or 3).
- Move the headrest to the desired position.
- Re-tighten the release handle.



8.8 Adjustment of the stand-up angle



Pre-requisites:

- Screwdriver, flat, width of edge approx. 6 mm



WARNING: The Verticalizer could be destroyed if the position of the upper shut-off switches is changed!

- *Never modify the position of the upper shut-off switches!*

The control box (1) for the limit stop of the verticalizer is to be found under the seat.

- Raise the verticalizer.



- Use the screwdriver to carefully release the rubber cover at the upper end of the control box and remove.



There are three limit switches in the control box, two at the upper end and one at the lower end. The lower limit switch (1) is the one used to adjust the stand-up angle. Never change the position of the upper shut-off switches!

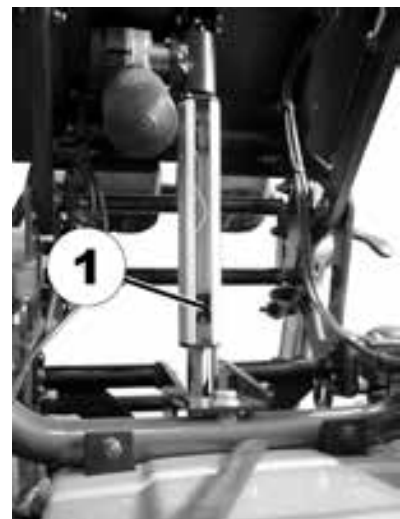

- Use the screwdriver to loosen the fastening screw on the limit switch (1).
- Slide the limit switch upward or downward.
- Upward = actuator is shut down earlier when standing up, user is erected to a lesser degree.
- Downward = actuator is shut down later when standing up, user is erected to a greater degree.
- Re-tighten the fastening screw.

- Re-position the rubber cover and press carefully into the groove using the screwdriver.

