

Invacare® Action3 NG RC/MWP*

* Rocking Chair/Mid Wheel Propulsion

en

Manual Wheelchair

Service Manual



DEALER: Keep this manual.

The procedures in this manual **MUST** be performed by a qualified technician.



Yes, you can.

Contents

I	Trouble Shooting and Maintenance Guidelines	3
1.1	Troubleshooting	3
1.2	Tightening Torques.....	4
1.3	Suggested Maintenance Procedures	4
1.4	Stability Warning	5
2	Central Wheels and Front Castors	6
2.1	Removing/Installing Central Wheels.....	6
2.1.1	Removing Central Wheels (24" or 22")	6
2.1.2	Installing Central Wheels (24" or 22")	7
2.2	Adjusting Quick-Release Axles.....	8
2.3	Replacing Handrims	8
2.4	Adjusting Wheelbase Length	9
2.5	Change Central Wheel Size (24" or 22")	10
2.6	Adjusting Forks.....	11
2.7	Removing/Installing Castor Assemblies	11
2.7.1	Removing Front Wheels.....	11
2.7.2	Installing Front Wheels.....	11
3	Wheel Brakes	12
3.1	Adjusting Wheel Brakes	12
3.1.1	Adjusting Wheel Brake Shoe Position (step 1).....	12
3.1.2	Adjusting Wheel Brake Shoe Position (step 2).....	13
4	Anti-Tipper Arm	14
4.1	Adjusting Anti-Tipper Wheel Height.....	14
5	Periodic Maintenance Guidelines	15
5.1	Inspect/Adjust Initially	15
5.2	Inspect/Adjust Weekly.....	16
5.3	Inspect/Adjust Monthly	16
5.4	Inspect/Adjust Annually	16

I Troubleshooting and Maintenance Guidelines

General Information

User manual and pre-sales information:

For pre-sales information and user manual related to this wheelchair, please consult the www.invacare.eu.com website.

NOTICE: For general maintenance, refer to the same section, in the ordinary Action3 NG Service Manual. Always use this document in combination with the ordinary Service Manual.

NOTE: Please recommend the user to follow the rules mentioned in the User Manual about Maintenance Schedule, Cleaning and Troubleshooting sections.

I.1 Trouble Shooting

Fault	Possible cause	Action
The wheelchair tips backwards too easily	Central wheels are mounted too far forwards	Mount the central wheels further back, → qualified technician
	Recline too large	Reduce the recline, → qualified technician
	Tilt too large	Mount the front wheel higher on the front fork, → qualified technician
The brakes are gripping poorly or asymmetrically	Incorrect tyre pressure in one or both central tyres	Correct the tyre pressure, → see tyre pressure table in the Action3 NG user manual
	Brake setting incorrect	Correct the brake setting, → qualified technician
Rolling resistance is very high	Tyre pressure in central tyres is too low	Correct the tyre pressure, → see tyre pressure table in the Action3 NG user manual
	Central wheels not parallel	Ensure the central wheels are parallel, → qualified technician
The anti-tipper wheel is stiff or stuck	Bearings are dirty or faulty	Clean or replace the bearings, → qualified technician

CAUTION

It is compulsory to use original Invacare spare parts which you can obtain from any Invacare subsidiaries. A list of spare parts is available at www.invacare.eu.com.

WARNING

After ANY adjustments, repair, or service and before use, make sure all attaching hardware is tightened securely - otherwise injury or damage may occur.

CAUTION

DO NOT overtighten the bolt connections of any hardware attached to the frame. This could cause damage to the frame tubing.

1.2 Tightening Torques

The tightening torques stated in the following table are dependent on the thread diameters for the nuts and bolts for which no special values are determined. All values apply to dry and grease-free threads.

Thread	M4	M5	M6	M8	M10/12
Tightening torque in Nm mini/max.	1,5/3 Nm	3/6 Nm	7/12 Nm	10/20 Nm	20/30 Nm

CAUTION

All other nuts not noted here must be tightened FINGERTIGHT!

1.3 Suggested Maintenance Procedures

1. Before using your wheelchair, make sure all nuts and bolts are tight. Check all parts for damage or wear and replace if necessary. Check all parts for proper adjustment.
2. Keep quick release axles free of dirt and lint to ensure positive locking and proper operation.

WARNING

DO NOT use WD-40, 3-in-1 oil, or other penetrating lubricants on quick-release axles. Otherwise, binding and/or damage to the wheelchair may occur.

3. Clean quick release axles once a week with a Teflon lubricant.

WARNING

DO NOT use your wheelchair unless it has the proper tire pressure (BAR, KPa or P.S.I.).

DO NOT over inflate the tires. Failure to follow these suggestions may cause the tire to explode and cause bodily harm. The recommended tire pressure is on the sidewall of the tire.

4. Recommended tire pressure is listed on the sidewall of the tire (BAR, KPa or P.S.I.).

CAUTION

As with any vehicle, the wheels and tires must be checked periodically for cracks and wear and must be replaced if damaged.

5. The wheels, castors and tires must be checked periodically for cracks and wear and must be replaced when necessary.
6. Regularly check for loose spokes in the rear wheels. If loose, have them adjusted.
7. Periodically check handrims to ensure they are secured to the rear wheels.

8. Periodically check caster wheel bearings to make sure they are clean and free from moisture. Use a Teflon® lubricant if necessary.
9. Check upholstery for sagging, rips or tears.
10. Clean upholstery with mild soap and water.

1.4 Stability Warning

The seat height, seat depth, back angle, seating system/upholstery, size/position of the central wheels, size/position of the front castors, seating options (e.g., back bag, ...) as well as the user condition directly relate to the stability of the wheelchair.

Any change to one or any combination of these factors changes the centre of gravity and may cause the wheelchair to increase/decrease in stability.

<i>NOTE: When changes to the left hand column occur, follow across the chart and refer to the X procedure to maintain the proper stability, safety and handling of the wheelchair.</i>	SEAT HEIGHT	SEAT DEPTH	BACK ANGLE	SEATING SYSTEM/UPHOLSTERY	CASTOR SIZE	CASTOR POSITION	REAR WHEEL SIZE	REAR WHEEL POSITION	USER CONDITION	WHEEL BRAKES	ANTI-TIPPERS
SEAT HEIGHT	•	X	X	X	X	X	X	X	N/A	N/A	N/A
SEAT DEPTH	X	•	X	X	X	X	X	X	N/A	N/A	N/A
BACK ANGLE	X	X	•	X	X	X	X	X	N/A	N/A	N/A
SEATING SYSTEM/UPHOLSTERY	X	X	X	•	X	X	X	X	X	N/A	N/A
CASTOR SIZE	X	N/A	X	N/A	•	X	X	X	N/A	X	X
CASTOR POSITION	X	N/A	X	N/A	X	•	X	X	N/A	X	X
REAR WHEEL SIZE	X	N/A	X	N/A	X	X	•	X	N/A	X	X
REAR WHEEL POSITION	X	N/A	X	N/A	X	X	X	•	N/A	X	X
USER CONDITION	X	X	X	X	X	X	X	X	•	N/A	N/A

TABLE 1.3 Stability of the wheelchair

Seat-to-floor heights have specific positions depending on central wheel size, central wheel position, front castor size/position and seat-to-floor angle.

NOTE: Refer to section Changing Seat-to-floor Height table in the ordinary Action3 NG Service Manual.

2 Central Wheels and Front Castors

2.1 Removing/Installing Central Wheels

WARNING

The seat height, seat depth, back angle, seating system, size/position of the central wheels, size/position of the front castors, seating options (e.g., back bag, ...) as well as the user condition directly relate to the stability of the wheelchair. Any change to one or any combination of these factors changes the centre of gravity and may cause the wheelchair to increase/decrease in stability. Refer to the TABLE 1.3 in section 1.4 Stability Warning.

After ANY adjustments, repair, or service and BEFORE use, make sure all attaching hardware is tightened securely - otherwise injury or damage may occur.

FIGURE 2.1

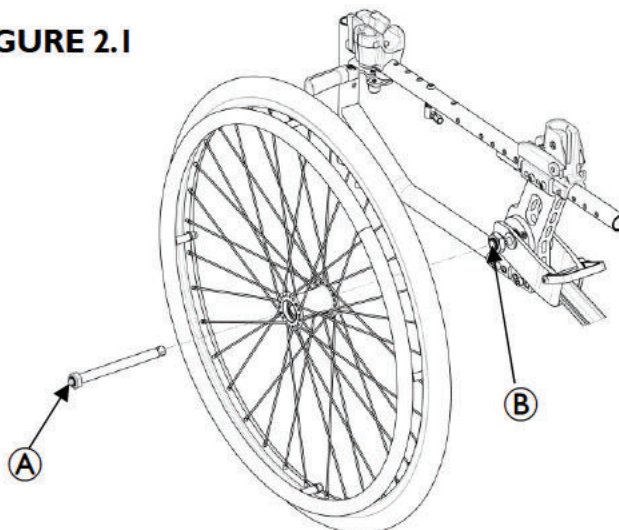

2.1.1 Removing Central Wheels (24" or 22")

NOTE: For this procedure, refer to FIGURE 2.1.

1. Hold the centre of the central wheel and push in the tip **A** of the quick release axle.
2. Pull the quick release axle and central wheel out of the axle bracket **B** on the wheelchair frame.
3. Push in the tip **A** of the quick release axle again and pull the quick release axle out of the existing central wheel.
4. Install new/existing central wheel onto wheelchair. Refer to the Installing procedure in this section.

WARNING

Make sure the detent pin and locking pins of the quick-release axle are fully released before operating the wheelchair.

The locking pins **MUST** be protruding past the inside of central wheel hub for a positive lock.

Keep locking pins clean.

Invacare recommends inserting quick-release axles with the head end to the inside of the wheelchair to prevent accidental release during contact leisure activities.

2.1.2 Installing Central Wheels (24" or 22")

NOTE: For this procedure, refer to FIGURE 2.1.

1. Install the existing quick release axle through the new/existing central wheel.
2. Install the new/existing central wheel and quick release axle into the axle bracket (B) on the wheelchair frame. Refer to section 2.2 Adjusting Quick-Release Axles if the locking pins are not protruding past the inside of the axle bushing or there is too much movement of the central wheel assembly in a back and forth position.

NOTE: The front castor needs to be adjusted at the same position in accordance with the central wheel size (24" or 22").

Refer to sections *Adjusting Castor Angle* and *Adjusting Castor Assembly Position and Changing Seat-to-floor Height table*, in the ordinary Action3 NG Service Manual.

2.2 Adjusting Quick-Release Axles

NOTE: For this procedure, refer to FIGURE 2.2.

1. Remove central wheel and quick release axle from the wheelchair. Refer to section 2.1 Removing/Installing Central Wheels
2. Depress detent pin in the quick release axle and slide the quick release axle through the central wheel hub.
3. Release detent pin to ensure that the locking pins are fully released.
4. Increase or decrease end play by adjusting the locknut on the end of the quick release axle.

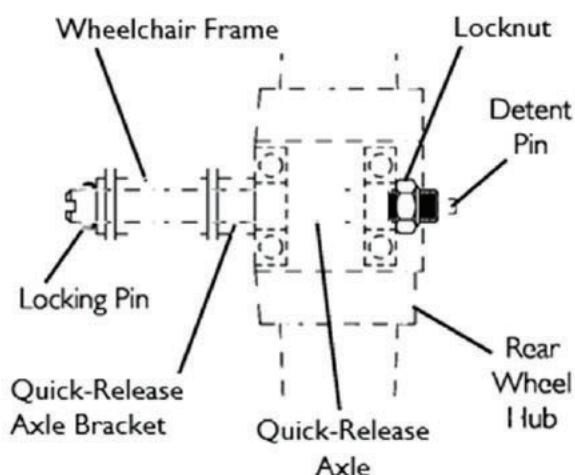

FIGURE 2.2 Adjusting Quick-Release Axles

WARNING

Make sure the detent pin of the quick release axle is fully released BEFORE operating the wheelchair.

Keep locking pins clean.

5. Reinstall central wheel onto the wheelchair. Refer to section 2.1 Removing/Installing Central Wheels.
6. Repeat STEPS 4 to 5 until the quick release axle detent pins are fully released past the wheelchair frame.

2.3 Replacing Handrims

NOTE: for this procedure, refer to FIGURE 2.3.

1. Remove the central wheel from the wheelchair. Refer to section 2.1 Removing/Installing Central Wheels
2. Remove the mounting screws that secure the existing handrim to the central wheel.
3. Remove the existing handrim.
4. Install the new handrim and secure to the central wheel with the existing mounting screws.
5. Reinstall the central wheel to the wheelchair. Refer to Removing/Installing Central Wheels paragraph.
6. Repeat STEPS 1 to 5 for opposite wheel, if necessary.

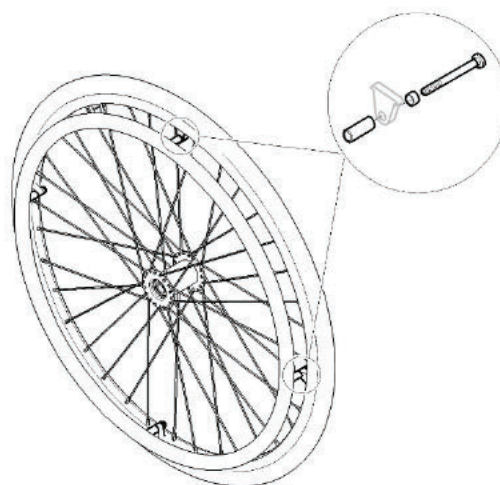

FIGURE 2.3

2.4 Adjusting Wheelbase Length

NOTE: For this procedure, refer to FIGURE 2.1 to section 2.1 Removing/Installing Central Wheels.

1. Remove the wheel. Refer to section 2.1 Removing/Installing Central Wheels paragraph.
2. Remove the four mounting screws (A) that secure the top and bottom of the adjustable axle bracket (B) to the back-cane bracket (C).
3. Align the adjustable axle bracket (B) with the adjustment holes on the back-cane bracket (C). There are 3 positions possible: Factory setting is position "A" Standard, position "B" is more Passive (better stability), position "C" is more Active (better maneuverability).

NOTE: For this procedure, refer to FIGURE 2.4.

WARNING

The four mounting screws need to be four adjustment holes apart to maintain frame integrity.

Active position "C" and Passive position "B" (not factory settings) of the axle plates directly relate to the stability of the wheelchair. Any change to one or any combination of the 3 positions may cause the wheelchair to increase/decrease in stability.

4. Secure the adjustable axle bracket to the back-cane bracket, at the desired length, with the locknut and washer (D).
5. Repeat STEPS 1 to 4 for the other axle bracket.

NOTE: Both adjustable axle brackets should be set at the same position.

FIGURE 2.4

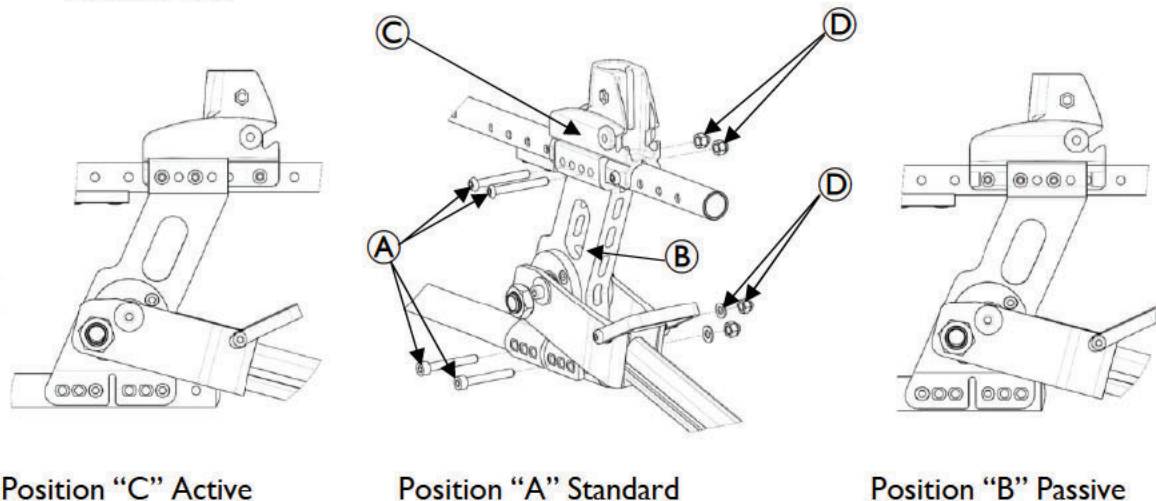

2.5 Change Central Wheel Size 610mm (24") or 560mm (22")

NOTE: For this procedure, refer to FIGURE 2.5 and to sections 2.1 Removing/Installing Central Wheels and 3.1 Adjusting Wheel Brakes.

1. Remove the central wheel from the wheelchair. Refer to section 2.1 Removing/Installing Central Wheels.
2. Install the new central wheel. Refer to section 2.1 Removing/Installing Central Wheels.
3. Repeat STEPS 1 to 2 for the other central wheel.

NOTE: The front castor needs to be adjusted at the same position in accordance with the central wheel size 610mm (24") or 560mm (22") and the seat-to-floor heights (24" = 485mm; 22" = 460mm).

Refer to section Changing Seat-to-floor Height table, in the ordinary Action3 NG Service Manual.

FIGURE 2.5

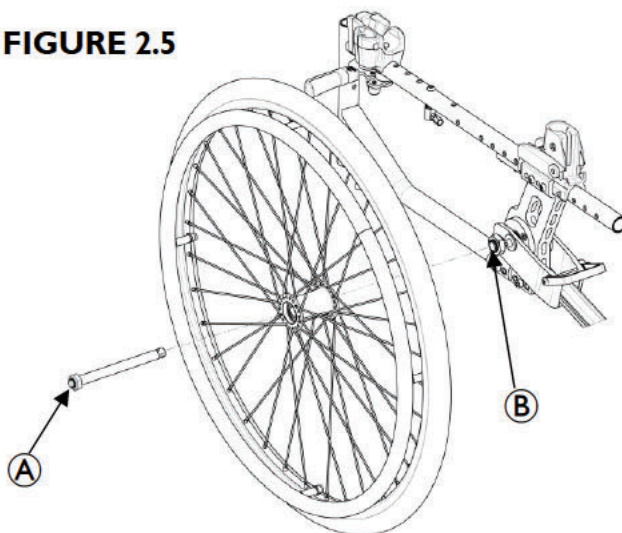

2.6 Adjusting Forks

WARNING

Risk of wobbling castors

Caster angle vertical axis **MUST** be at $90^{\circ} \pm 1^{\circ}$ from the ground. Both castor assemblies should be at the same angle.

After **ANY** adjustments, before use, make sure all attaching hardware is tightened securely - otherwise, injury or damage may occur.

NOTE: For this procedure, refer to sections Adjusting Castor Angle and Adjusting Castor Assembly Position, in the ordinary Action3 NG Service Manual.

2.7 Removing/Installing Castor Assemblies

NOTE: If replacing a front castor note the mounting position of the existing front castor for installation of the new front castor.

*NOTE: Both front castors **MUST** be the same size and adjusted to the same height.*

NOTE: For this procedure, refer to Seat-to-floor heights table in the ordinary Action3 NG Service Manual.

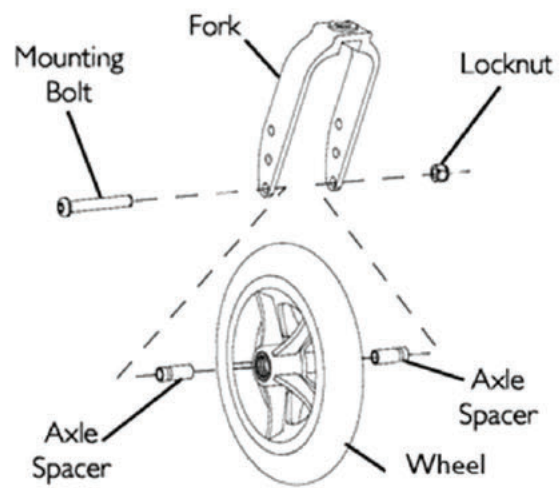

FIGURE 2.6 : Removing/Installing/Repositioning the front wheel

2.7.1 Removing Front Wheels

NOTE: For this procedure, refer to FIGURE 2.6.

1. Remove the mounting bolt, axle spacers (if present) and locknut that secure the front wheel to the fork.
2. Remove the wheel from the fork.

2.7.2 Installing Front Wheels

NOTE: For this procedure, refer to FIGURE 2.6.

1. Using the mounting bolt, axle spacers (if present) and locknut, secure the wheel to the desired wheel mounting position.
2. Ensure fork stem is perpendicular to the flat surface.

3 Wheel Brakes

⚠ WARNING

On steep slopes you can lose braking control of your wheelchair and overturn. Do not take slopes exceeding 4° to ensure perfect braking control of the wheelchair.

3.1 Adjusting Wheel Brakes

NOTE: When changing the size of the central wheels (24" or 22"), the wheel brakes **MUST** be readjusted.

NOTE: Before adjusting or replacing the wheel brake assemblies, ensure that the tires are inflated to the recommended BAR, KPa, P.S.I on the side wall of the tire.

NOTE: For this procedure, refer to FIGURE 3.1.1

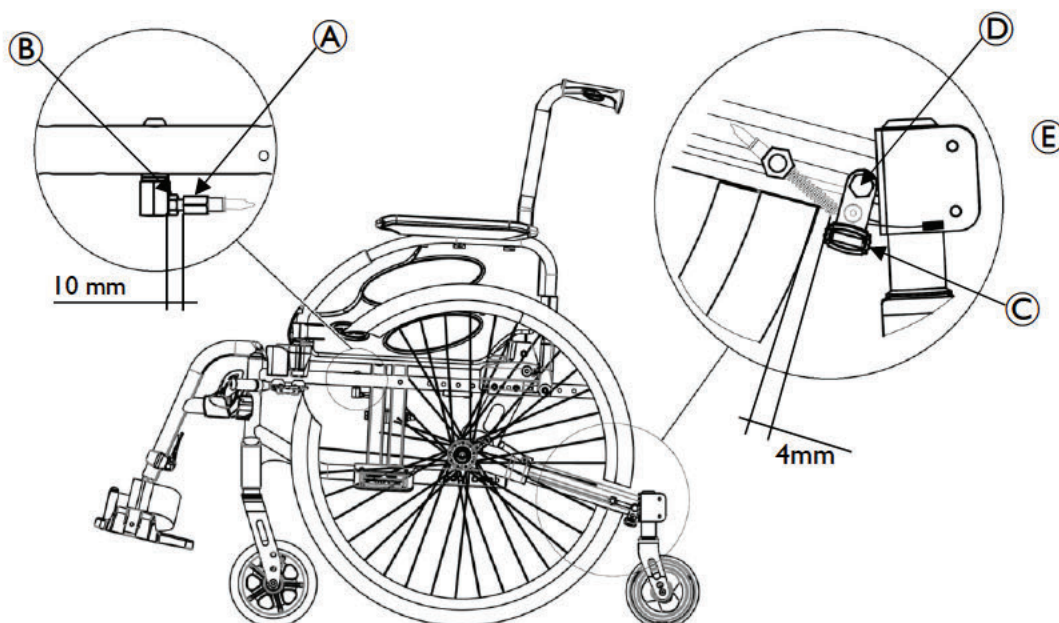

FIGURE 3.1.1

3.1.1 Pre-adjusting Wheel Brake Shoe Position (step 1)

NOTE: For this procedure, refer to FIGURE 3.1.2, next page

1. Remove the central wheel. Refer to section 2.1 Removing/Installing Central Wheels.
2. The hand brake lever must be in forward position.
3. Pre-adjust the distance around 10mm with the adjustment nut **A** (8mm spanner).
4. Securely tighten the fixation nut **B** (8 mm spanner).
5. Repeat STEPS 1 to 4 for the opposite side.

3.1.2 Adjusting Wheel Brake Shoe Position (step 2)

CAUTION

The brake cable must be changed on each side EVERY YEAR.

NOTE: For this procedure, refer to FIGURE 3.1.2 and 3.1.3

Finalize the shoe brake adjustment by adjusting its position on the anti-tipper arm.

1. Adjust the cable tension with the locking nut ⑤ (10mm spanner and Allen key 3mm/2-3 Nm) to obtain a shoe bracket position to 90° with anti-tipper arm.
2. Install the central wheel. Refer to section 2.1 Removing/Installing Central Wheels.
3. Adjust the shoe brake ③ position with the adjustment screw ④ (10mm spanner) until the measurement is 4 mm for solid tire and for pneumatic.
4. Securely tighten the adjustment screw ④ (10mm spanner/5-6 Nm).
5. Repeat STEPS 1 to 4 for the opposite wheel brake.
6. Engage the wheel brakes and push against the wheelchair to determine if the wheel brakes engage the central wheels enough to hold the occupied wheelchair in a slope of 4° with a maximum user weight of 125 kg.
7. Repeat STEPS 1 to 5 until the wheel brakes engage the central wheels enough to hold the occupied wheelchair.

FIGURE 3.1.2

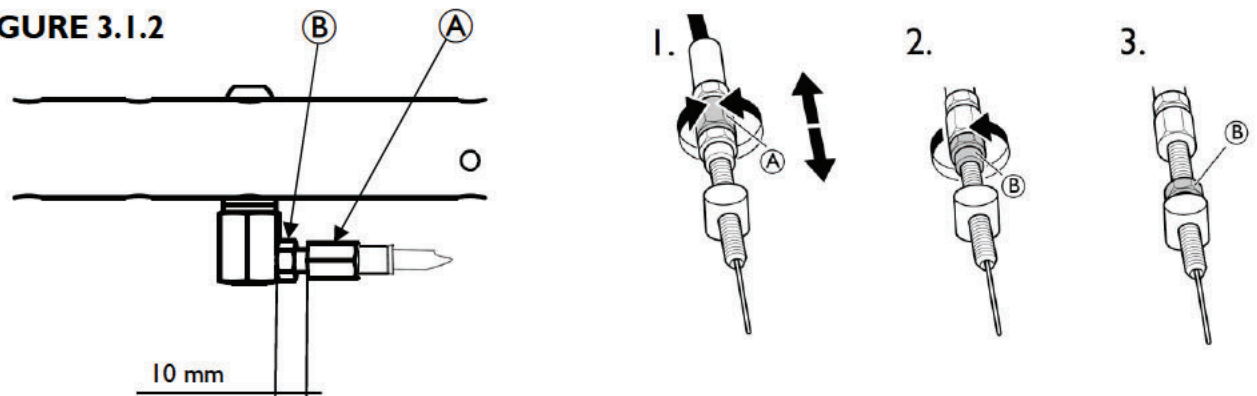
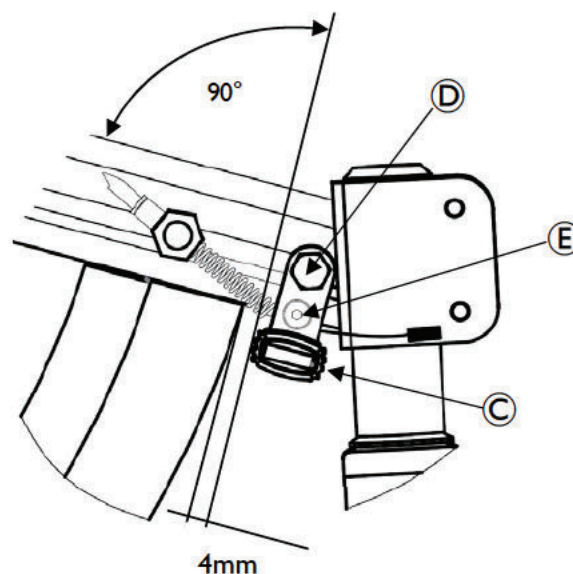

FIGURE 3.1.3



4 Anti-Tipper Arm

WARNING

After ANY adjustments, repair, or service and BEFORE use, make sure all attaching hardware is tightened securely - otherwise injury or damage may occur.

Ensure both anti-tipper arms are fitted correctly on each side before using the wheelchair and have it set or readjusted if necessary.

Always check that security levers are activated in forwards position, close to the adjustable axle bracket before using the wheelchair.

NOTE: This adjustment is required with reference to the position and diameter of the central wheel as well as the user's conditions and his/her safety limits.

4.1 Adjusting Anti-Tipper Wheel Height

NOTE: For this procedure, refer to FIGURE 4.1.

1. Unscrew but do not remove the adjusting screws **A** that secures the vertical axle **B** to the anti-tipper wheel bracket.
2. Adjust vertical axle to the two desired heights **C** = 485mm (central wheel 24") **D** = 460mm (central wheel 22") with one of the two adjustment circles on the vertical axle body.
3. Secure the vertical axle to the anti-tipper wheel bracket, at the desired height, with the adjusting screws **A** (5mm Allen key/8-9 Nm).
4. Repeat STEPS 1 to 3 for the other side.

NOTE: Make sure that the anti-tipper wheel is fitted at the same height on both sides.

FIGURE 4.1

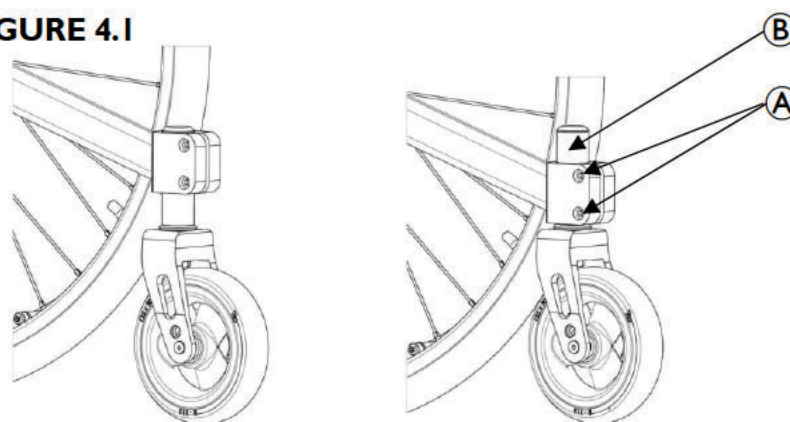

C = 485mm (central wheel 24")

D = 460mm (central wheel 22")

5 Periodic Maintenance Guidelines

IMPORTANT: For general Periodic Maintenance Guidelines, refer to same section, in the ordinary Action3 NG Service Manual. Always use this document in combination with the ordinary Service Manual.

NOTE: Always clean the wheelchair before any inspection/adjustment. Regular cleaning will reveal loose or worn parts and enhance the smooth operation of the wheelchair.

Initial Inspection:

Initial adjustments should be made to suit the personal body structure needs and preferences of the user. Thereafter follow these maintenance procedures:

5.1 Inspect/Adjust Initially

- Wheelchair rolls straight (no excessive drag or pull to one side).
- Ensure all hardware is tight (see page 4).
- All fasteners on clothing guards are secure.
- Adjustable height arms operate and lock securely.
- Armrest armpad sits flush against arm tube.
- Seat and/or back upholstery have no rips.
- Inspect adjustable angle back attaching hardware is securely tightened.
- Ensure hand grips are secure to backrest canes.
- Sealed bearings and axle nut tension are correct.
- No excessive side movement or binding when rear wheels are lifted and spun.
- Quick-release axles lock properly (see page 8).
- Inspect handrims for signs of rough edges or peeling finish.
- Inspect for broken spokes.
- Wheel/fork assembly has proper tension when castor is spun. Castor should come to a gradual stop.
- Wheel bearings are clean and free of moisture.
- Loosen/tighten locknut if wheel wobbles noticeably or binds to a stop
- Ensure all castor/wheel/fork fasteners are secure (see pages 4 & 11).
- Wheel brakes do not interfere with tires when rolling.
- Wheel brakes pivot point are free of wear and looseness.
- Wheel brakes are easy to engage.
- Inspect tires/castors for flat spots and wear.
- Check pneumatic tires for proper inflation (recommended tire pressure is listed on the side wall of the tire).
- Ensure axles are free from dirt, lint, etc.
- Ensure roller bearings are free from dirt, lint, etc.
- Adjust wheel brakes as tires wear.
- Clean and wax all parts.
- Clean upholstery and armrests.
- Ensure castors are free of debris.

5.2 Inspect/Adjust Weekly

- Wheelchair rolls straight (no excessive drag or pull to one side).
- Quick-release axles lock properly (see page 8).
- Inspect for broken spokes.
- Wheel/fork assembly has proper tension when castor is spun. Castor should come to a gradual stop.
- Inspect tires/castors for flat spots and wear.
- Check pneumatic tires for proper inflation (recommended tire pressure is listed on the side wall of the tire).
- Ensure castors are free of debris.

5.3 Inspect/Adjust Monthly

- Inspect seat positioning strap for any signs of wear. Ensure buckle latches. Verify hardware that attaches strap to frame is secure and undamaged. Replace if necessary.
- Loosen/tighten locknut if wheel wobbles noticeably or binds to a stop.
- Wheel bearings are clean and free of moisture.
- Wheel brakes do not interfere with tires when rolling.
- Wheel brake pivot point are free of wear and looseness.
- Check the tension and appearance of the brake cable.
- Ensure all castor/wheel/fork/head tube fasteners are secure (see pages 4 & 11).
- Ensure all hardware is tight (see page 4).
- Ensure hand grips are secure to backrest canes.
- Ensure castors are free of debris.

5.4 Inspect/Adjust Annually (1)

- Wheelchair rolls straight (no excessive drag or pull to one side).
- Adjustable height arms operate and lock securely.
- Armrest armpad sits flush against arm tube.
- All fasteners on clothing guards are secure.
- Seat and/or back upholstery have no rips.
- Inspect adjustable angle back attaching hardware is securely tightened.
- No excessive side movement or binding when rear wheels are lifted and spun.
- Inspect handrims for signs of rough edges or peeling finish.
- Inspect tires/castors for flat spots and wear.
- Check pneumatic tires for proper inflation (recommended tire pressure is listed on the side wall of the tire).
- Wheel brake pivot point are free of wear and looseness.
- Clean upholstery and armrests.
- Sealed bearings and axle nut tension are correct.
- Wheel/fork assembly has proper tension when castor is spun. Castor should come to a gradual stop.
- Loosen/tighten locknut if wheel wobbles noticeably or binds to a stop.
- Wheel bearings are clean and free of moisture.

5.4 Inspect/Adjust Annually (2)

- Wheel brakes are easy to engage.
- Change brake cable and readjust the brake tension cable
- Ensure axles are free from dirt, lint, etc.
- Ensure roller bearings are free from dirt, lint, etc.
- Adjust wheel brakes as tires wear.
- Clean and wax all parts.
- Ensure castors are free of debris.

NOTES:

NOTES:

Invacare Sales Companies

Ireland:

Invacare Ireland Ltd,
Unit 5 Seatown Business
Campus
Seatown Road, Swords, County
Dublin
Tel: (353) 1 810 7084
Fax: (353) 1 810 7085
ireland@invacare.com
www.invacare.ie

United Kingdom:

Invacare Limited
Pencoed Technology Park, Pencoed
Bridgend CF35 5AQ
Tel: (44) (0) 1656 776 222
Fax: (44) (0) 1656 776 220
uk@invacare.com
www.invacare.co.uk



Invacare France Operations SAS
Route de St Roch
F-37230 Fondettes
France

60122664-C 2024-01-09

Making Life's Experiences Possible™



Yes, you can!