

KÜSCHALL **COMPACT** *attract*



©2018 Invacare Corporation

All rights reserved. Republication, duplication or modification in whole or in part is prohibited without prior written permission from Invacare Corporation. Trademarks are identified by TM and ©.

All trademarks are owned by or licensed to Invacare Corporation or its subsidiaries unless otherwise noted.



TABLE OF CONTENTS

GENERAL **5**

Introduction 5

Spare parts and adaptations 5

Fastening with hexagon socket bolts 5

Torque 6

Checks 6

Identifying and repairing faults 6

OVERVIEW **7**

Components 7

Dimensions 7

FRAME **8**

Rear frame 9

Front frame 9

Retaining lever 9

SEAT **10**

Seat height front (SHv) 10

Seat height rear (SHh) 11

Seat width (SB) 11

Seat depth (ST) 11

BACKREST **13**

Backrest height 13

Angle-adjustable backrest 14

Replacing push handles / push handles and backrest 16

Replacing foldable push handles 18

Stabilisation bar 18

Backrest parts for adjustable backs with respect to backrest height 19

LEGRESTS **23**

Replacing legrest parts 23

FOOTRESTS **24**

Two-piece footrest 24

Two-piece footrest, adjustable-angle 24

SIDEPARTS **25**

Clothes guard/mudguard 25

Siderests 26

FRONT WHEELS **30**

Replacing a front wheel 30

Front wheel fork 30

Special housing guides 31

REAR WHEELS **32**

Adjusting the seat height rear 32

Tipping stability 32

Wheel camber 33

Adjusting the removable axle 33

Repairing or changing an inner tube 34

Repairing or changing a solid tire 34



BRAKES	35
Parking brakes	35
Drum brake	36
OPTIONS & ACCESSORIES	37
Antitipper	37
Tipper aid/Cane holder	38
Fitting the posture belt	39
Attaching the snap hook symbols	39



GENERAL

Introduction

This Service Manual contains all the technical information necessary for the inspection, configuration or repair of a küschall® wheelchair.



WARNING!

Danger of accident and severe injuries.

If the wheelchair is improperly set it can cause accidents and severe injuries.

▸ **Changes to the wheelchair may only be carried out by the dealer.**

To maintain the necessary levels of safety and reliability, every wheelchair must be thoroughly examined once a year.

Some aspects of the assembly and configuration of the wheelchair require a high level of expertise. These assembly instructions therefore break the various tasks down into three categories:

Requirement	Symbol
Easy – technical understanding required	●○○
Medium – technical knowledge required	●●○
Difficult – technical knowledge and expertise in assembling wheelchairs required	●●●

The required tools and their sizes are listed before the instructions. The various torque values with which the nuts are to be tightened are also specified in the instructions. A torque spanner must be used, in order to comply with the specified torque values.

Tool	Symbol
Allen key	● 3, 4, 5
Torx wrench	* 8, 10, 20
Phillips head screwdriver	×
Slot screwdriver	⊖
Open-end spanner	—C 8, 9, 10, 18
Socket spanner/Box spanner	⬡ 8, 10, 19, 22

Spare parts and adaptations

All spare parts may be obtained from the Invacare Customer Service department. An electronic spare parts catalogue can be found at www.kuschall.com. Only original spare parts may be used. The written authorisation of Invacare Corporation must be obtained before installing additional adaptations on a küschall® wheelchair.

Fastening with hexagon socket bolts

Hexagon socket bolts are not designed to withstand an excessive application of force. When tightening or undoing a hexagon socket bolt, force should be applied to the nut wherever possible to avoid damaging the bolt.

Tightening and undoing

- Turn the nut using a socket spanner (only use an open-end spanner if there is insufficient space), using the Allen key simply to stop the bolt turning.

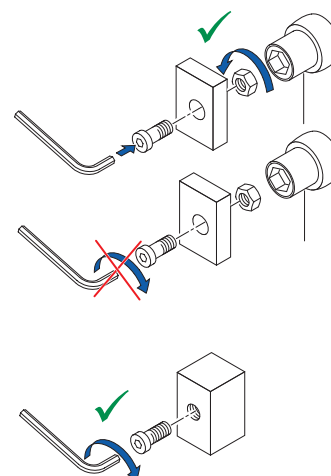



Tightening and undoing when no nut is present

If a hexagon socket bolt is screwed directly into a thread, the bolt must be tightened using the Allen key.

 Ensure that the Allen key is of good quality and not worn.

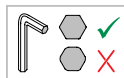

Torque

■ All bolts must be tightened with the torque specified in the following instructions.

Checks

Visual check

■ Check all components for cracks, especially the areas around joints and welded seams.

Checking the screw connections

■ Check all bolts with the torques specified in the instructions regularly, and adjust if required.



CAUTION!

Several screw connections have been secured with thread locking adhesive. If these are opened, they must be secured again using new thread locking adhesive. Liquid high-strength and low-strength adhesives are available. For torque specifications it is pointed out whether an adhesive and which adhesive needs to be used.

Identifying and repairing faults

Fault	Possible cause	Action
The wheelchair does not travel in a straight line	Incorrect tyre pressure on one rear wheel	Correct tyre pressure
	One or more spokes broken	Replace broken spoke(s)
	Spokes tightened unevenly	Tighten loose spokes
	Front wheel bearings are dirty or damaged	Clean or replace the bearings
	Support bearings in forks faulty	Replace the support bearings
The wheelchair tips too easily	Steering error or trail angle, left and right, uneven	Adjust steering error or trail angle
	Rear wheels are mounted too far forwards	Mount the rear wheels further back
	Backrest angle too large	Reduce backrest angle
The brakes are gripping poorly or asymmetrically	Seat angle too large	Mount the adapter plate lower on the side profile
	Incorrect tyre pressure in one or both rear tyres	Correct tyre pressure
The rolling resistance is very high	Brake setting incorrect	Correct brake setting
	Tyre pressure in rear tyres is too low	Correct tyre pressure
	Rear wheels not parallel	Make rear wheels parallel
	Drum brake set too narrow	Set the drum brake
The front wheels wobble when moving fast	Bearings are dirty or faulty	Replace the bearings
	Too little tension on the clevis pin housing	Tighten the screw on the front wheel fork slightly
The front wheel is stiff or stuck	Front wheel has worn smooth	Replace front wheel
	Bearings are dirty or faulty	Replace the bearings
The wheelchair is very difficult to unfold	The backrest cover is too tight	Loosen the topmost hook and loop band of the backrest cover a little
Left and right side of the wheelchair can be moved in parallel to one another	Longitudinal stopping bolts on the seat edge are loose	Tighten the longitudinal stopping bolts on the seat edge



OVERVIEW

Components

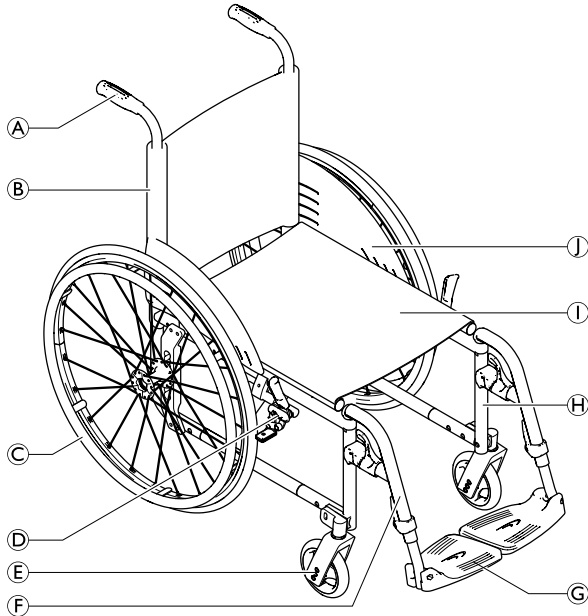

Ⓐ	Push handles
Ⓑ	Backrest
Ⓒ	Rear wheel with handrim
Ⓓ	Parking brake
Ⓔ	Front wheel fork with front wheel
Ⓕ	Legrest
Ⓖ	Footplate
Ⓗ	Frame
Ⓘ	Seat
⓵	Clothes-guard

Dimensions

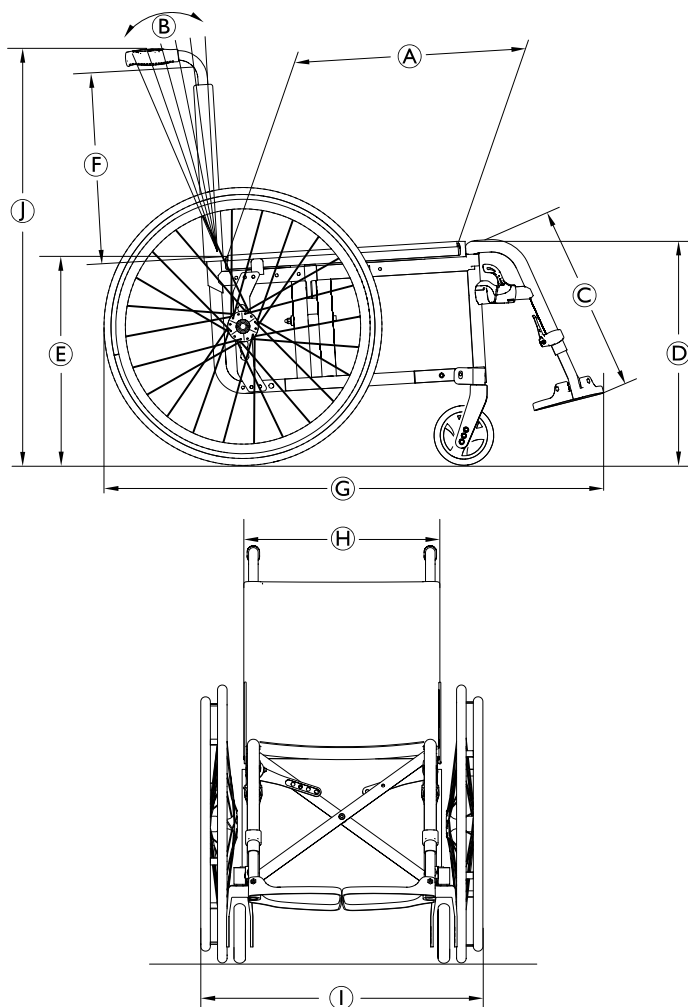

Ⓐ	Seat depth	360 – 500 mm, in increments of 20 mm
Ⓑ	Backrest angle	0° – 24°, in increments of 4°
	Seat plane angle	0° – 12°
Ⓒ	Knee-to-heel length	380 – 460 mm, in increments of 10 mm
	Leg to seat surface angle	95° – 120°
Ⓓ	Seat height front	430 – 520 mm, in increments of 10 mm
Ⓔ	Seat height rear	400 – 490 mm, in increments of 10 mm
Ⓕ	Backrest height	330 – 495 mm, in increments of 15 mm
Ⓖ	Overall length with leg rests	825 – 1155 mm
Ⓗ	Effective seat width	360 – 500 mm, in increments of 20 mm
Ⓘ	Overall width	535 – 730 mm
⓵	Overall height	740 – 1070 mm
	Folded length	280 – 370 mm
	Folded width	280 – 370 mm
	Folded height	740 – 1070 mm
	Armrest to seat height	200 – 335 mm
	Front location of armrest structure	170 – 360 mm
	Hand rim diameter	520 – 540 mm
	Horizontal location of axle (3 positions, also depending on seat angle)	35 – 103 mm



FRAME

- Ⓐ Rear frame
- Ⓐ₁ → 13 Nm
- Ⓐ₂ → 7 Nm
- Ⓑ Retaining lever
- Ⓑ₁ → 4 Nm
- Ⓒ Cross
- Ⓓ Front frame
- Ⓓ₁ → 13 Nm
- Ⓓ₂ → 7 Nm
- Ⓔ Upper connecting tube
- Ⓕ Lower connecting tube
- Ⓖ Seat locking mechanism
- Ⓖ₁ → 4 Nm
- Ⓖ₂ → 4 Nm
- Ⓗ Vertical brace
- Ⓗ₁ → 6 Nm
- Ⓘ Threaded insert

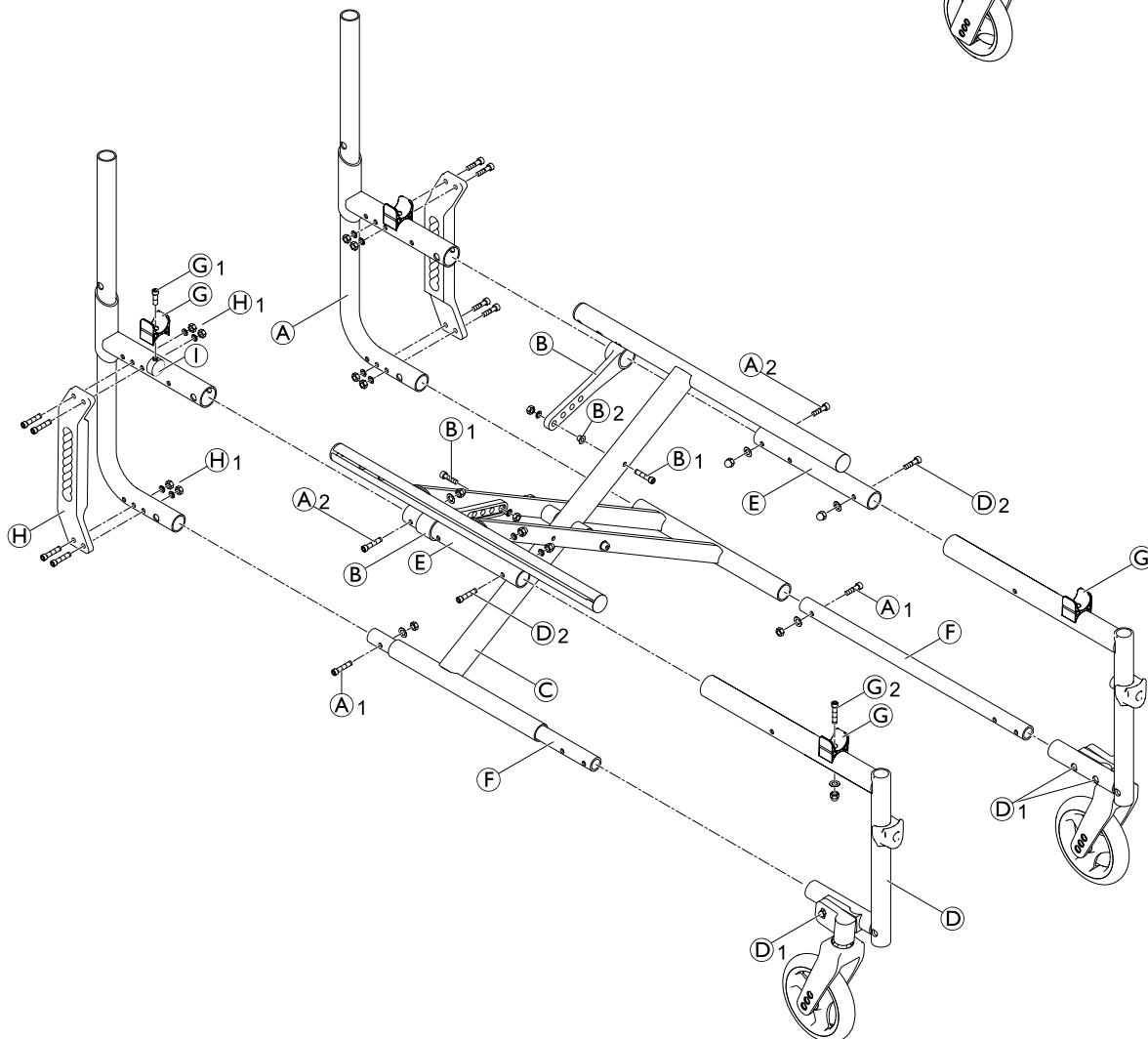
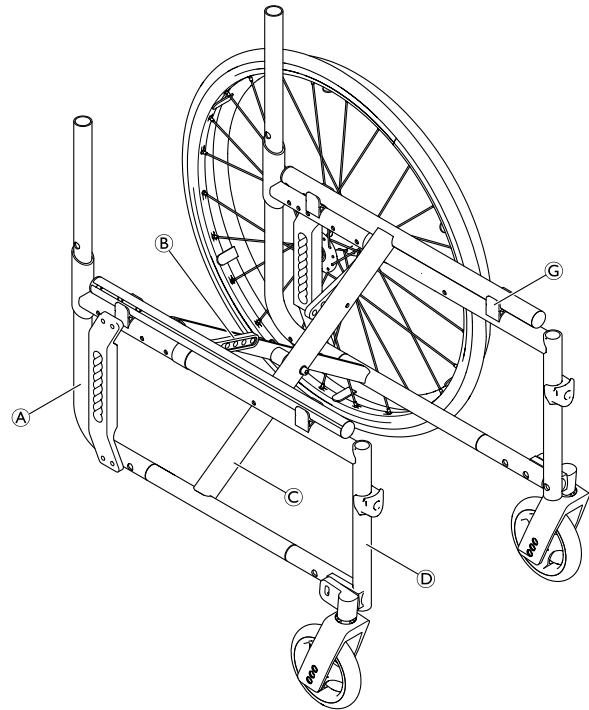



Rear frame

Replacing the rear frame

Difficulty: ●●○

Tools: ● 5 10

- Remove backrest.
- Loosen and remove bolts Ⓐ1 and Ⓐ2.
- Pull out rear frame Ⓐ to the back.
- Remove seat locking mechanism Ⓒ from old front frame and fit it on the new front frame,
→ Chap. Seat; Turning the seat locking mechanism.
- Push the rear frame onto the upper Ⓔ and lower Ⓕ connecting tubes.
- Reinsert and tighten bolts Ⓐ1 and Ⓐ2.

Front frame

Replacing the front frame

Difficulty: ●●○

Tools: ● 3, 4, 5 10

- Disassemble brakes.
- Loosen and remove bolts Ⓓ1 and Ⓓ2 on both sides.
- Pull out front frame Ⓓ to the front.
- Remove seat locking mechanism Ⓒ from old front frame and fit it on the new front frame,
→ Chap. Seat; Turning the seat locking mechanism.
- Push the front frame onto the upper Ⓔ and lower Ⓕ connecting tube.
- Reinsert and tighten bolts Ⓓ1, Ⓓ2 on both sides.
- Set the front wheel fork angle,
→ Chap. Front wheels; Setting the steering error angle.

Retaining lever

Replacing the retaining lever

Difficulty: ●●○

Tools: ● 4, 5 10

- With mudguard or clothes guard, fixed: remove Ⓐ1 and Ⓓ2, with mudguard or side rest, insertable and siderest, foldable: remove Ⓐ1 and Ⓐ2.
- Remove bolt Ⓑ1.
- Pull the retaining lever Ⓑ from the upper connecting tube Ⓔ.
- Remove sleeve Ⓑ2.
- Push the new retaining lever over the upper connecting tube Ⓔ.
- Position sleeve Ⓑ2 with wide edge in the aluminium tube.
- Secure retaining lever with bolt Ⓑ1.
- With mudguard or clothes guard, fixed: reinsert and tighten bolts Ⓐ1 and Ⓓ2, with mudguard or side rest, insertable and side rest, flip to back: reinsert and tighten bolts Ⓐ1 and Ⓐ2.









SEAT

Seat height front (SHv)

Options for changing the SHv:

- Replace front wheel with larger or smaller one or fit it at another position on the front wheel fork,
→ Chap. Front wheels Replacing the front wheel.
- Replace front wheel fork with a larger or a smaller one,
→ Chap. Front wheels; Replacing the front wheel fork.
- Fit it high/low with the housing guide Hemi,
→ Chap. Front wheels; Special housing guides.

<i>Seat height front with respect to fork size, front wheel fork size and position in the fork</i>						
<i>SHv [mm]</i>	 5"	 5"	 6"	 6"	 8"	 8"
430	● 5" *					
440	● 5" *					
450		● 5" *				
460	● 5"	● 6" *				
470	● 5"		● 6" *			
480		● 5"		● 6" *		
490		● 6"	● 5"		● 7" *	
500			● 6"	● 5"		● 7" *
510			● 7"	● 6"	● 5"	
520				● 7"	● 6"	● 5"

(Assumption: Seat depth = 400 mm, seat angle = 50 mm)

* fitted high: SHv - 30 mm



Seat height rear (SHh)

Options for changing the SHh:

- Replace rear wheel with a larger or a smaller one
- Change the position of the adapter plate, → Chap. Rear wheels.

<i>Seat height rear with respect to the rear wheels and positioning on the frame</i>	
<i>SHh [mm]</i>	<i>Rear wheel size [inch]</i>
	24"
400	1
410	2
420/430	3
440	4
450	5
460	6
470/480	7
490	8

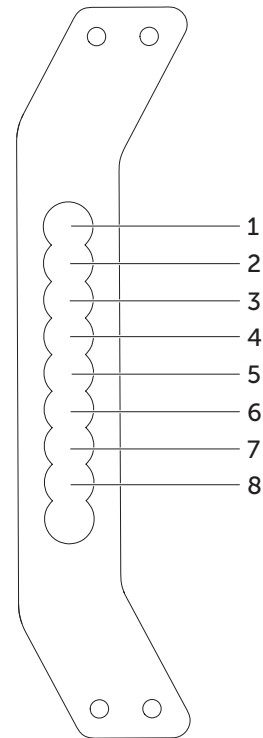

Seat width (SB)

SBs range from 360 - 500 mm.

Once the SB is specified, it is very difficult to change it: the cross struts, backrest cover (on standard backs), seat cover and, on some configurations, the footrests must be replaced.

Seat depth (ST)

STs range from 360 - 500 mm.

To reduce the ST, the cross struts must be shortened, a new appropriately sized seat cover fitted and the connecting tubes shortened or replaced. At an ST \geq 400 mm, the frame can be shortened.

To enlarge the ST, new cross struts, a new appropriately sized seat cover, new connecting tubes and, depending on the ST, a new frame must be installed.



Replacing the seat cover

Difficulty: ●●○

Tool: ✕ 10

- 1 Loosen bolts (A) and remove plug (B).
- 2 Remove seat cover including plastic rods.
- Position new seat cover.
- Retighten bolts (A) and plug (B).

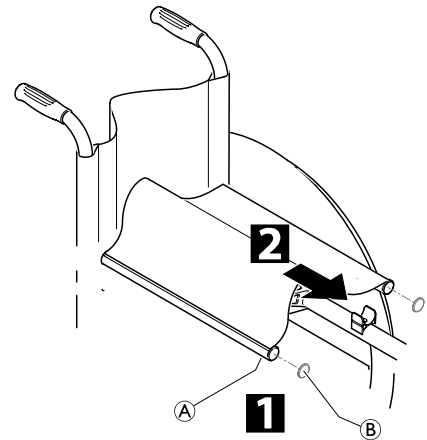

Turning the seat locking mechanism

If the seat can be too easily removed from the seat locking mechanisms, either the front two or all four seat locking mechanisms can be rotated by 180°:

Difficulty: ●○○

Tool: —C 8, ● 3

- 1 At the front and/or rear, loosen bolt in seat locking mechanism (A).
- Turn seat locking mechanism by 180°.
- Retighten the bolt.

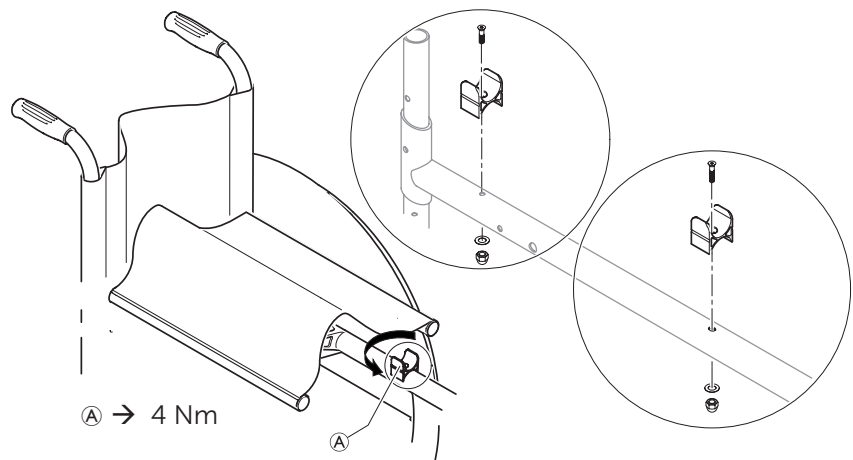



BACKREST

Backrest height

The backrest height can be changed by fitting the telescopic tubes into another position in the backrest tubes. If this setting option is insufficient, the telescopic tubes can be replaced.

Adjusting the height of standard backrests

Difficulty: ●○○

Tools: ● 3, 4, 5 ◻ 8, 10

- Push the backrest cover (A) upwards and remove the bolt (B) on both sides.
- Push the push handles (C) upwards or downwards until you reach the required height. Replace the bolt and tighten.

i If this setting range is insufficient, use new push handle tubes.

i If the backrest height was changed considerably, a new backrest cover may have to be fitted.

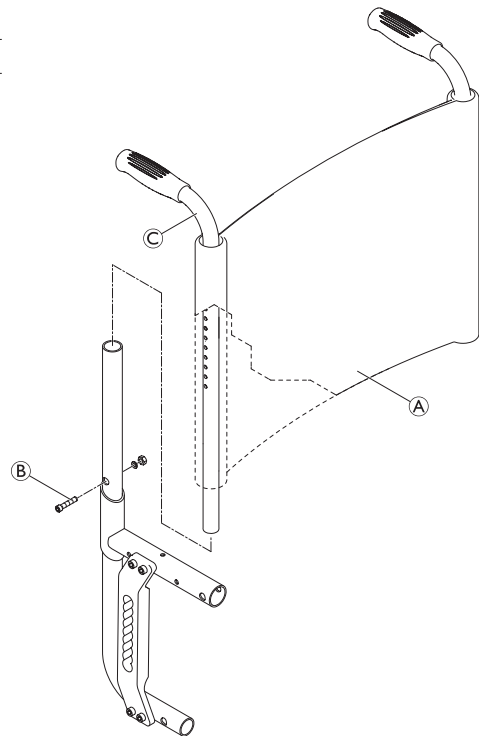

Adjusting the height of hook and loop adjustable backrests

Difficulty: ●○○

Tools: ● 3, 4, 5 ◻ 8, 10

- Remove backrest cover (B) and move the hook and loop bands (C) until bolt (A) is visible.
- Remove bolt (A) and move the push handle tube (D) to the required height.
- Insert bolt (A) into the appropriate hole and tighten.

i If the backrest height is changed considerably, the push handle tubes must be replaced. An additional hook and loop band may have to be fitted or one may have to be removed.

i If the backrest height was changed considerably, a new backrest cover may have to be fitted.

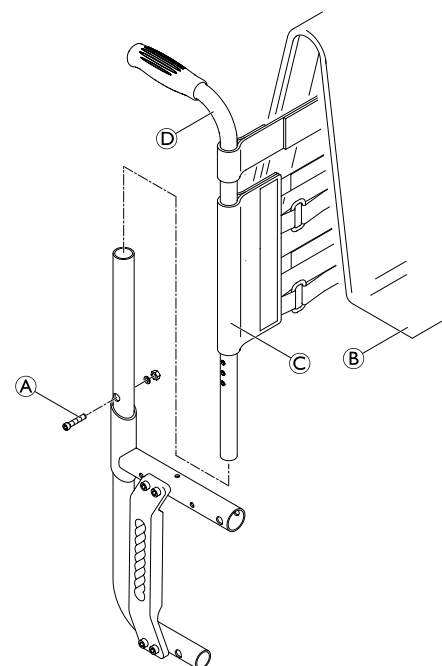



Angle-adjustable backrest

In order to make the backrest angle adjustable, angle-adjustable backrest can be fitted.

Backrest angle

Position	Deviation from standard backrests	Angle between backrest and seat
1	12°	102°
2	8°	98°
3	4°	94°
4	0°	90°
5	-4°	86°
6	-8°	82°

Fitting an angle-adjustable backrest

Difficulty: ●●○ Tools: ● 3, 4, 5 ⬡ 8, 10 — C10 × 10

Shorter rear frame required.

- Push the lower joint pin **B** into the rear frame **A** and fix it using a bolt.
- Secure backrest tube **F** to the upper joint pin **C** using a bolt. Assemble the upper and lower joint pins **C** and **B** and secure with bolt **D**.
- Set the desired backrest angle and secure in the nearest hole using bolt **E**.
- Tighten the bolt **D**.
- Push the single hook and loop band **H** and then the other hook and loop bands **I** and end band **J** over the backrest tube **F**.
- Push the push handle **G** into the telescopic tube **F** and fix at the required height.
- Secure end band **J** on the telescopic tube **G** with a bolt.

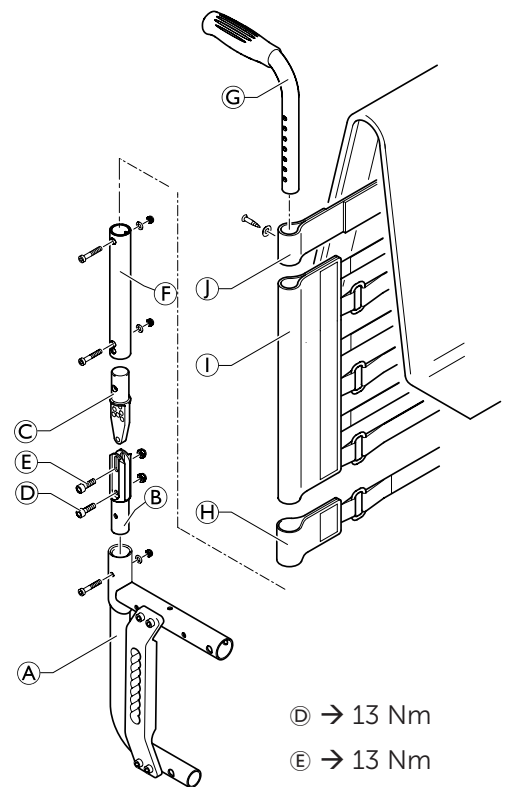

D → 13 Nm

E → 13 Nm



Setting the backrest angle

Difficulty: ●●○

Tools: ● 5 ⬡ 10 — C10

- 1 Remove the backrest cushion (B) and push the hook and loop bands (C) upwards, until the backrest joint (A) is invisible.
 - 2 Remove the bolt (D) and loosen bolt (E).
 - 3 Set the desired backrest angle, insert the bolts (D) in the nearest hole and tighten.
- Retighten the bolt (E).
 - Perform the same setting on both sides.

Visual check

By looking from the side check that both backrest tubes are level and thus that the same angle has been set on both sides.

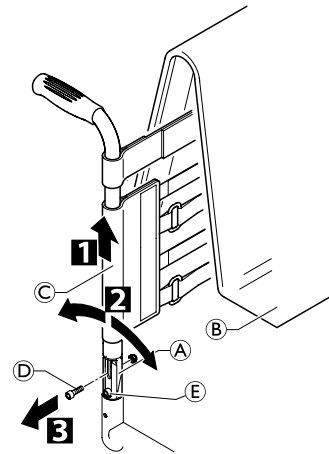

Ⓓ → 13 Nm

Ⓔ → 13 Nm



Replacing push handles / push handles and backrest

If the push handles are replaced with a different type of push handles, e.g. height-adjustable ones, it can happen that the rear frame must also be replaced.

Changing the backrest height can also mean that the configuration of the hook and loop bands must be changed.

Fitting standard push handles

Difficulty: ●●○

Tools: ✕ ● 3, 4, 5 ⬡ 8, 10

- Secure the telescopic tube ④ to the rear frame ① at the required height using bolt ⑤.
- Push the backrest bands ② and end band ③ onto the telescopic tube ④, end band first.
- Secure end band ③ on the telescopic tube ④ with a bolt ⑥.

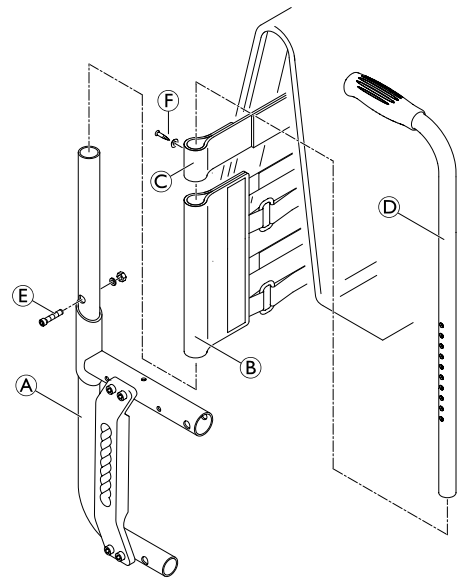

Fitting height adjustable integrated push handles

Difficulty: ●●○

Tools: ✕ ● 3, 4, 5 ⬡ 8, 10

Special rear frame required for RH 300 – 465.

- Push lower telescopic tube ② and upper telescopic tube ③ into one another and insert bolt.
- Secure pre-assembled element (telescopic tubes ② and ③) at the required height on the rear frame ① with bolt ④.
- Push the hook and loop bands ⑤ and end band ⑥ onto the telescopic tubes.
- Using the clamp bolt ⑦ secure the height adjustable push handles ⑧ through the telescopic tube ③.
- Push in push handle completely.
- Secure end band ⑥ on the telescopic tube ③ with bolt ⑩.

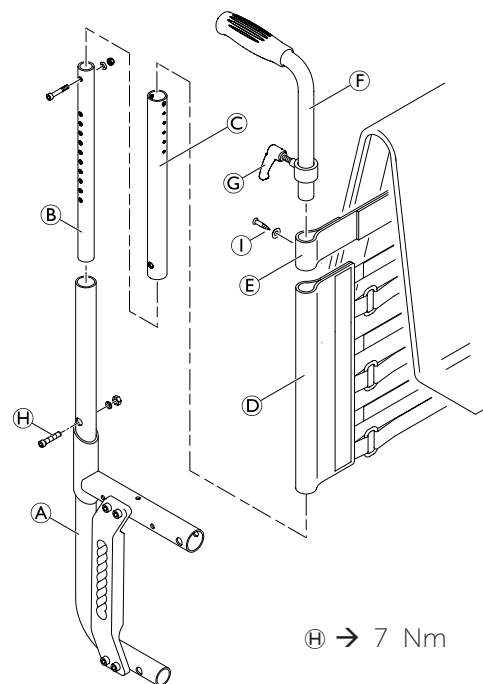

④ → 7 Nm



Fitting height adjustable, rear set push handles

Difficulty: ●●○

Tools: ✕ ● 3, 4, 5 ⬡ 8, 10

The hook and loop bands may have to be replaced with narrower ones, as space is required to secure the holder on the telescopic tube.

- Secure the telescopic tube (B) to the rear frame (A) at the required height.
- Press the cover cap (F) onto the end of the telescopic tube.
- Push the hook and loop bands (C) onto the telescopic tube.
- Push the holder (E) onto the telescopic tube and fix in place by tightening the clamp bolts.
- Fit end band (D) onto the telescopic tube and secure with a bolt.
- Attach protective cushion.

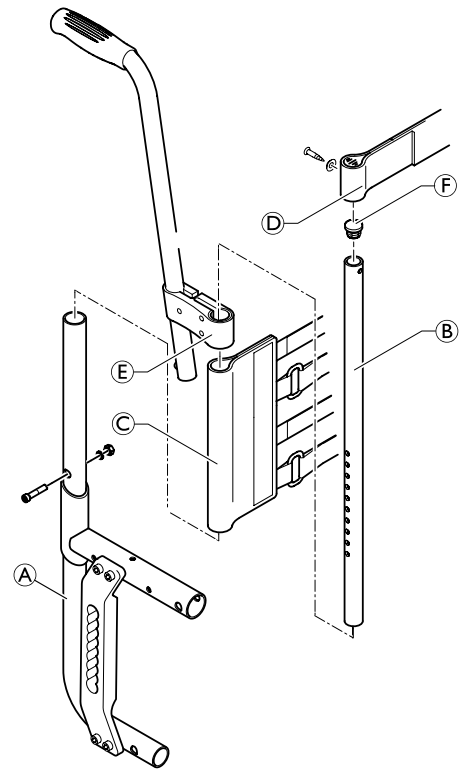

Fitting angle-adjustable backrest with height-adjustable push handles

Difficulty: ●●○

Tools: ✕ ● 3, 4, 5 ⬡ 8, 10 — C10

Shorter rear frame (variant III) required.

- Push the lower joint pin (B) into the rear frame (A) and fix it using the bolts.
- Fit backrest tube (F) onto the upper joint pin (C) using bolts. Assemble the upper and lower joint pins (C) and (B) and secure with a bolt (D).
- Set the desired backrest angle and secure in the nearest hole using a nut and bolt (E).
- Retighten the bolt (D).
- Push the single hook and loop band (H) and then the other hook and loop bands (I) and end band (J) over the backrest tube (F).
- Push in push handle completely.
- Using the clamp bolt (K) fit the height-adjustable push handles (G) through the telescopic tube (F).
- Fit end band (J) onto the telescopic tube (F) with a bolt.

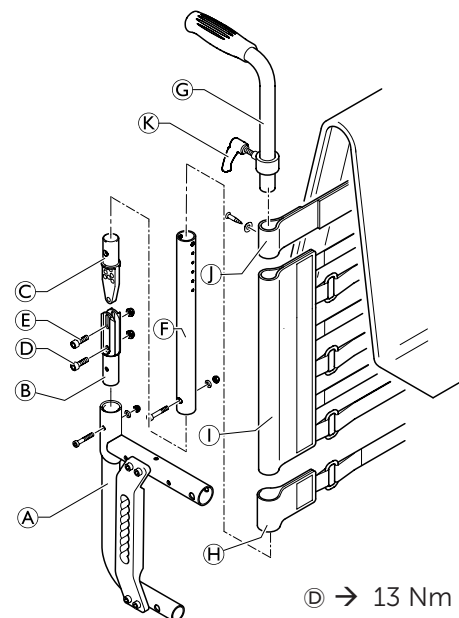

D → 13 Nm

E → 13 Nm



Replacing foldable push handles

Difficulty: ●○○

Tools: Hole punch pliers 6 mm, ● 3, 4

- Remove the old foldable push handle.
- Pull down the backrest cover (F) on the telescopic tube, until its hole (B) is uncovered.
- ! **IMPORTANT!**
Make sure that the threaded insert (E) (part no. 1580450) supplied with the new push handle is used for assembly.
- Place the threaded insert (E) in the telescopic tube.
- Punch a hole through the backrest cover with a distance of 10 mm from the upper edge, using hole punch pliers (see graphic below).
- Slide the new foldable push handle (A) onto the telescopic tube.
- Pull up the backrest cover, until it covers completely the rear hole in the push handle.
- Fix the foldable push handle with screw (C) and washer (G).
- Check screws (D) on both sides of the push handle and re-tighten if necessary.
- Carry out the same steps for the other push handle.

- ! **IMPORTANT!**
Make sure that the folding force is approximately 5 N (0.5 kg).
- ! **IMPORTANT!**
Fixing screw (C) may only be used once. Alternatively the screw can be cleaned (remove old thread locking adhesive) and reinstalled with new low-strength thread locking adhesive.

 The retrofit of foldable push handles requires new tubing.

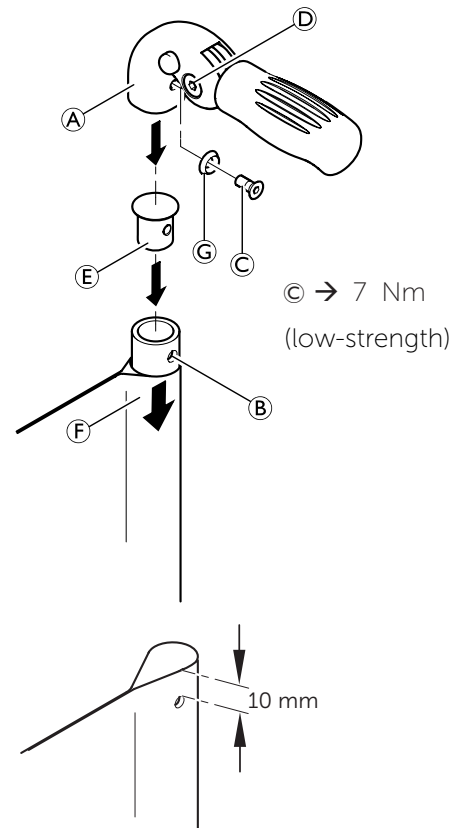

Stabilisation bar

Stabilisation bar assembly

Difficulty: ●●○

Tools: ● 3, 8 × 2

With a back height RH405 or larger it is possible to assemble a stabilisation bar to increase the rigidity of the backrest handles.

- Remove backrest cover (A), push handles (B) and 10 cm backrest band (or end band, if no push handles are assembled).
- Assemble a 5 cm backrest band (C) or end band with the screws (L) to the push handles (B).
- Assemble the push handles (B) with bolts and nuts (K).
- Attach the clamps (D) together with the RH socket (F) and the LH socket (H) with the screws (G) below the backrest band (C) to the push handles (B).
- Replace the push handle/backrest band/socket assembly.
- Press pin (E) and slide the stabilisation bar (J) into the RH socket (F) then swing the stabilisation bar upwards, press pin (I) and click the stabilisation bar into the LH socket (H).

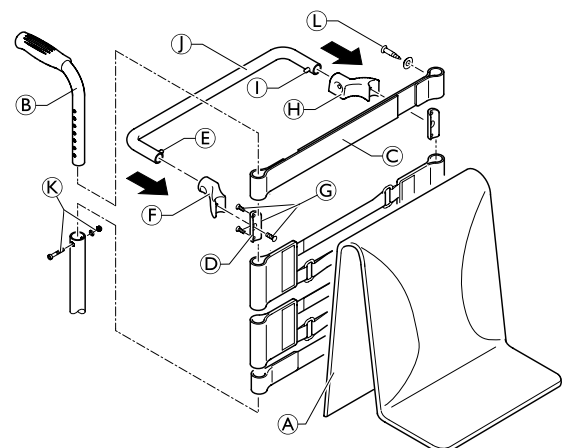

- G → 4 Nm
- K → 7 Nm
- L → 4 Nm



Backrest parts for adjustable backs with respect to backrest height

Fixed backrest with standard/mini pushhandles, foldable push handles* or without pushhandles:

Backrest height (RH) with respect to cover, backrest tubes, bands				
RH	Cover [Ⓑ]	Telescopic tube [Ⓐ] (straight/lumbar)	Bands (without stabilizing bar, endband [Ⓒ] = 10cm)	Bands (with stabilizing bar, endband [Ⓒ] = 5cm)
330	S	S	2x2-band	-
345	S	S	2x2-band	-
360	S	S	2x2-band	-
375	M	S	1-band + 2x2-band	-
390	M	S	1-band + 2x2-band	-
405	M	M	1-band + 4-band [Ⓕ]	1-band + 2x2-band
420	M	M	1-band + 4-band	2x1-band + 4-band
435	L	M	1-band + 4-band	2x1-band + 4-band
450	L	M	2-band + 4-band	2x1-band + 4-band
465	L	M	2-band + 4-band	1-band + 2-band + 4-band
480	L	M	2-band + 4-band	1-band + 2-band + 4-band
495	L	M	2-band + 4-band	1-band + 2-band + 4-band

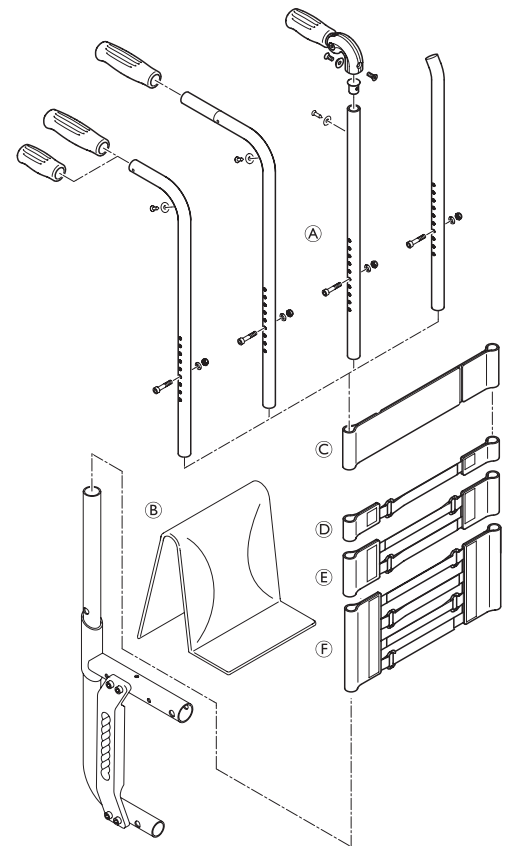

*Stabilization bar not possible for foldable push handles

Fixed or angle adjustable backrest with high adjustable push handles, rearset:

Backrest height (RH) with respect to cover, backrest tubes, bands				
RH	Cover [Ⓑ]	Telescopic tube [Ⓐ]	Bands (without stabilizing bar, endband [Ⓒ] = 10cm)	Bands (with stabilizing bar, endband [Ⓒ] = 5cm)
330	S	L	1-band [Ⓓ] + 2-band	-
345	S	L	1-band + 2-band	-
360	S	L	1-band + 2-band	-
375	M	L	2x2-band	-
390	M	L/XL*	2x2-band	-
405	M	XL	4-band [Ⓕ]	2x1-band + 2-band
420	M	XL	4-band	1-band + 4-band
435	L	XL	4-band	1-band + 4-band
450	L	XL	1-band + 4-band	1-band + 4-band
465	L	XL	1-band + 4-band	1-band + 4-band
480	L	XL	1-band + 4-band	2-band + 4-band
495	L	XL	1-band + 4-band	2-band + 4-band

*Telescopic tube XL for angle adjustable backrest.

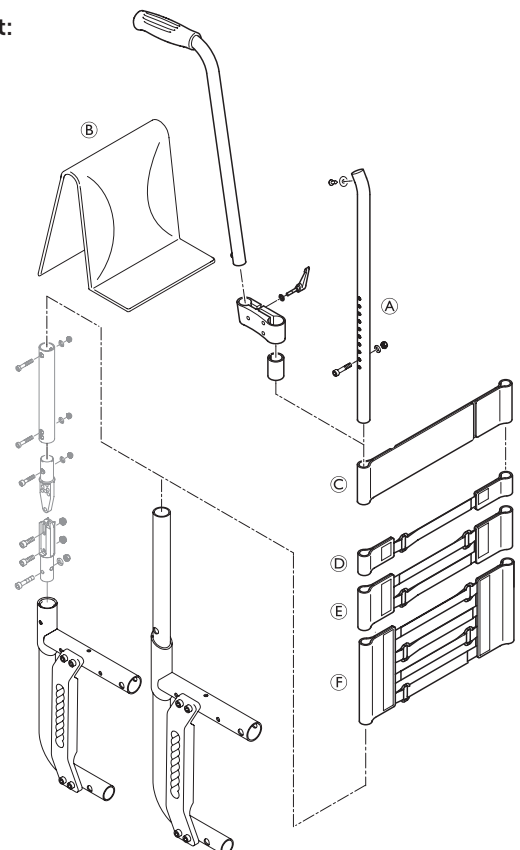



Fixed backrest with high adjustable push handles, integrated:

Backrest height (RH) with respect to cover, backrest tubes, bands*					
RH	Cover ©	Telescopic tube (straight)		Telescopic tube (lumbar)	
		Backrest tube ʙ	Push handle ʌ	Backrest tube ʙ	Push handle ʌ
330	S	S	S	S	S
345	S	S	S	S	S
360	S	S	S	S	S
375	M	S	L	S	S
390	M	S	L	S	S
405	M	S	L	M	S
420	M	S	L	M	S
435	L	S	L	M	L
450	L	S	L	M	L
465	L	S	L	M	L
480	L	S	L	M	L
495	L	M	L	M	L

*For bands configuration, see table „Fixed backrest with standard push handles“.

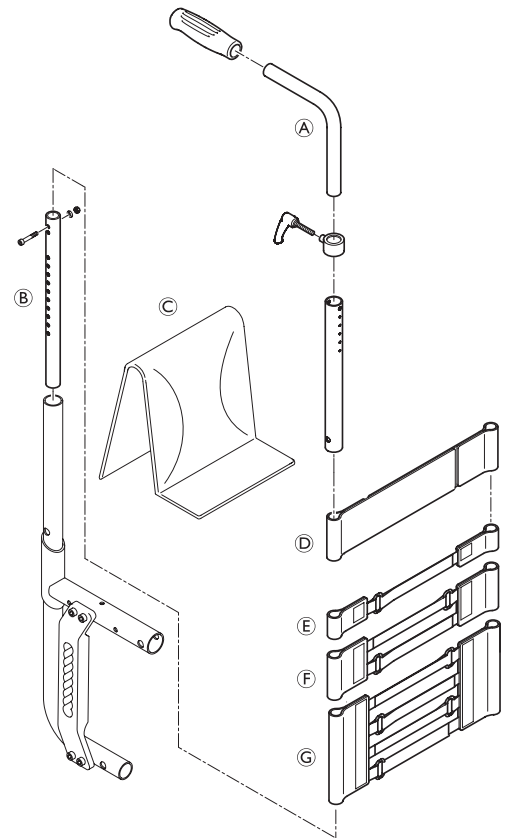

Angle adjustable backrest with standard/mini pushhandles, foldable push handles* or without pushhandles:

Backrest height (RH) with respect to cover, backrest tubes, bands				
RH	Cover ʙ	Telescopic tube ʌ	Bands (without stabilizing bar, endband © = 10cm)	Bands (with stabilizing bar, endband © = 5cm)
330	S	S	2 x 2-band	-
345	S	S	2 x 2-band	-
360	S	S	2 x 2-band	-
375	M	S	1-band + 2x2-band	-
390	M	L	1-band + 2x2-band	-
405	M	L	1-band + 4-band ʆ	1-band + 4-band
420	M	L	1-band + 4-band	2-band + 4-band
435	L	L	1-band + 4-band	2-band + 4-band
450	L	L	2-band + 4-band	2-band + 4-band
465	L	L	2-band + 4-band	2-band + 4-band
480	L	L	2-band + 4-band	1-band + 2-band + 4-band
495	L	L	2-band + 4-band	1-band + 2-band + 4-band

* Stabilization bar not possible for foldable push handles

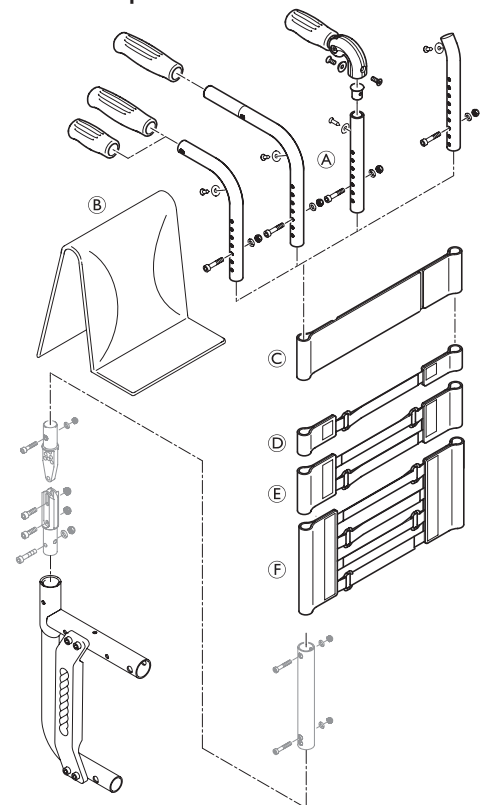



Angle adjustable backrest with high adjustable push handles, integrated:

Backrest height (RH) with respect to cover, backrest tubes, bands*			
Telescopic tube			
RH	Cover ③	Backrest tube ②	Push handle ①
330	S	S	S
345	S	M	L
360	S	M	L
375	M	M	L
390	M	M	L
405	M	M	L
420	M	L	L
435	L	L	L
450	L	L	L
465	L	L	L
480	L	L	L
495	L	XL	L

* For bands configuration, see table „Angle adjustable backrest with standard push handles“.

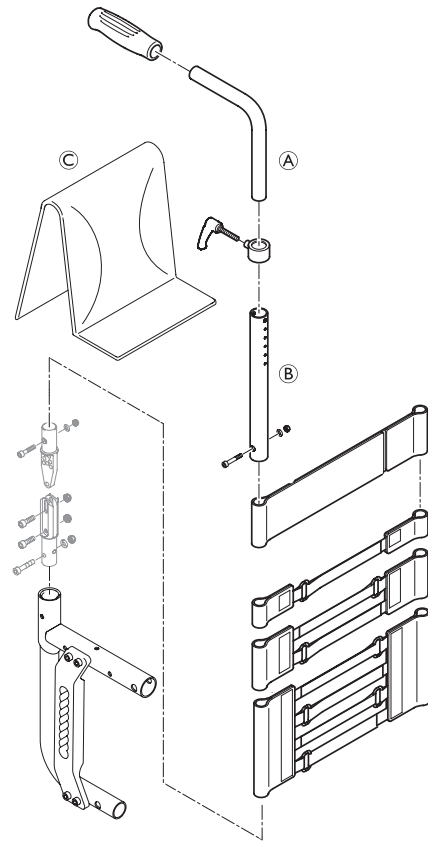

Foldable backrest with standard/mini pushhandles, foldable push handles¹⁾ or without pushhandles:

Backrest height (RH) with respect to cover, backrest tubes ²⁾ , bands				
RH	Cover ②	Telescopic tube ①	Bands (without stabilizing bar, endband ③ = 10cm)	Bands (with stabilizing bar, endband ③ = 5cm)
330	-	-	-	-
345	S	S	2x1-band ④	-
360	S	S	2x1-band	-
375	M	S	1-band + 2-band ⑤	-
390	M	S	1-band + 2-band	-
405	M	S	1-band + 2-band	2x2-band
420	M	S	2x2-band	2x2-band
435	L	L	2x2-band	1-band + 2x2-band
450	L	L	2x2-band	1-band + 2x2-band
465	L	L	1-band + 2x2-band	1-band + 4-band
480	L	L	1-band + 2x2-band	1-band + 4-band
495	L	L	1-band + 4-band ⑥	1-band + 4-band

¹⁾ Stabilization bar not possible for foldable push handles

²⁾ Backrest tubes lumbar possible from RH360

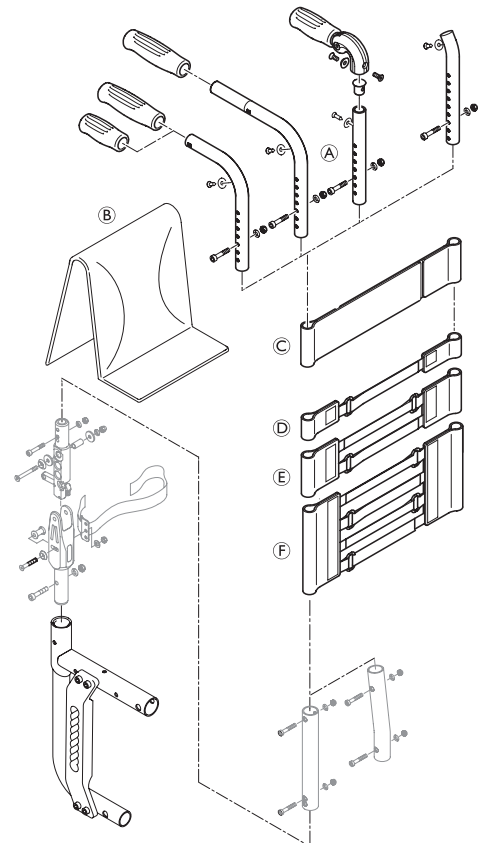



Foldable backrest with high adjustable push handles, rearset:

Backrest height (RH) with respect to cover, backrest tubes*, bands				
RH	Cover [Ⓑ]	Telescopic tube [Ⓐ]	Bands (without stabilizing bar, endband [Ⓒ] = 10cm)	Bands (with stabilizing bar, endband [Ⓒ] = 5cm)
330	-	-	-	-
345	S	S	2x1-band [Ⓓ]	-
360	S	S	2x1-band	-
375	M	S	2x1-band	-
390	M	S	2x1-band	-
405	M	S	1-band + 2-band [Ⓔ]	1-band + 2-band
420	M	S	1-band + 2-band	1-band + 2-band
435	L	L	1-band + 2-band	1-band + 2-band
450	L	L	2x2-band	2x2-band
465	L	L	2x2-band	2x2-band
480	L	L	2x2-band	2x2-band
495	L	L	1-band + 2x2-band	1-band + 2x2-band

* Backrest tubes lumbar possible from RH360

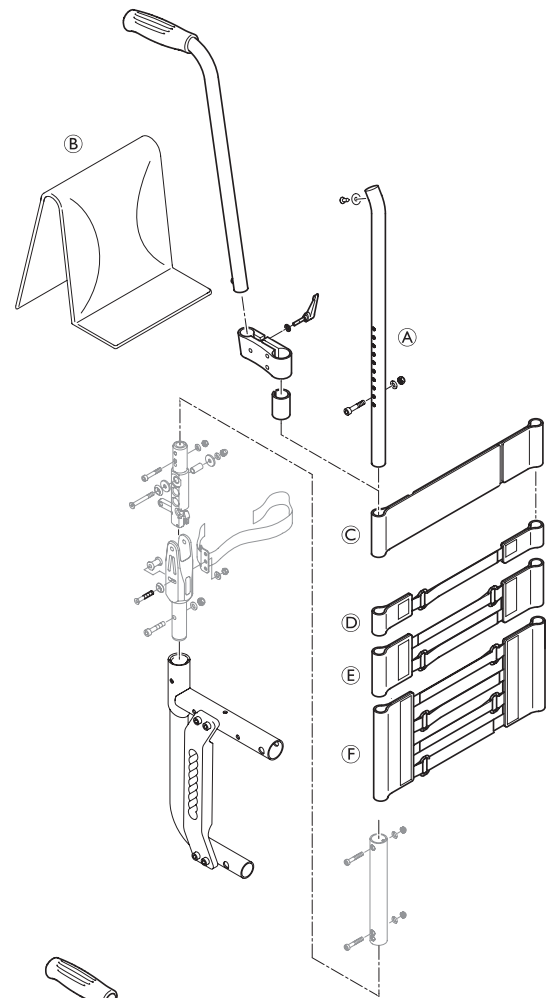

Foldable backrest with high adjustable push handles, integrated:

Backrest height (RH) with respect to cover, backrest tubes, bands*				
RH	Cover [Ⓒ]	Backrest tube [Ⓑ]	Push handle [Ⓐ]	
			Telescopic tube (82°,86°,90°)	Telescopic tube lumbar (94°,98°)
330	-	-	-	-
345	S	S	S	S
360	S	S	S	S
375	M	S	S	S
390	M	M	L	S
405	M	M	L	S
420	M	M	L	S
435	L	M	L	S
450	L	M	L	L
465	L	L	L	L
480	L	L	L	L
495	L	L	L	L

* For bands configuration, see table „Foldable backrest with standard push handles“.

For foldable backrests additionally a band is fixed close to the backrest joint. The band is of different length according to the seat width (SB): SB 280 - 360 → short / SB 380 - 440 → medium / SB 460 - 500 → long

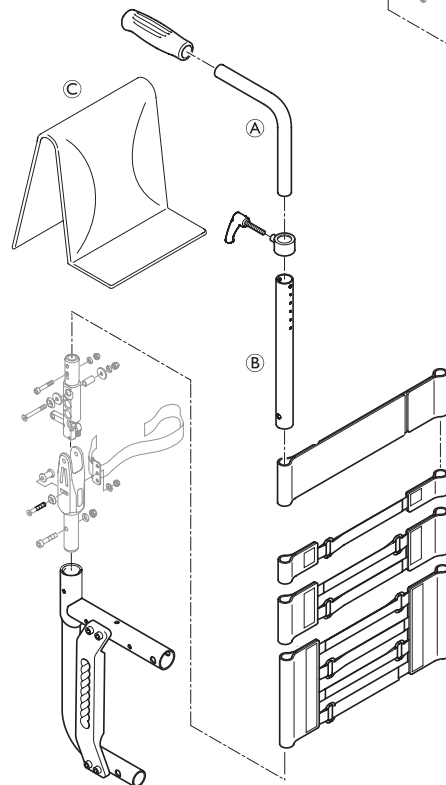



LEGRESTS

Legrests with angle measurements of 70° and 90° are available.

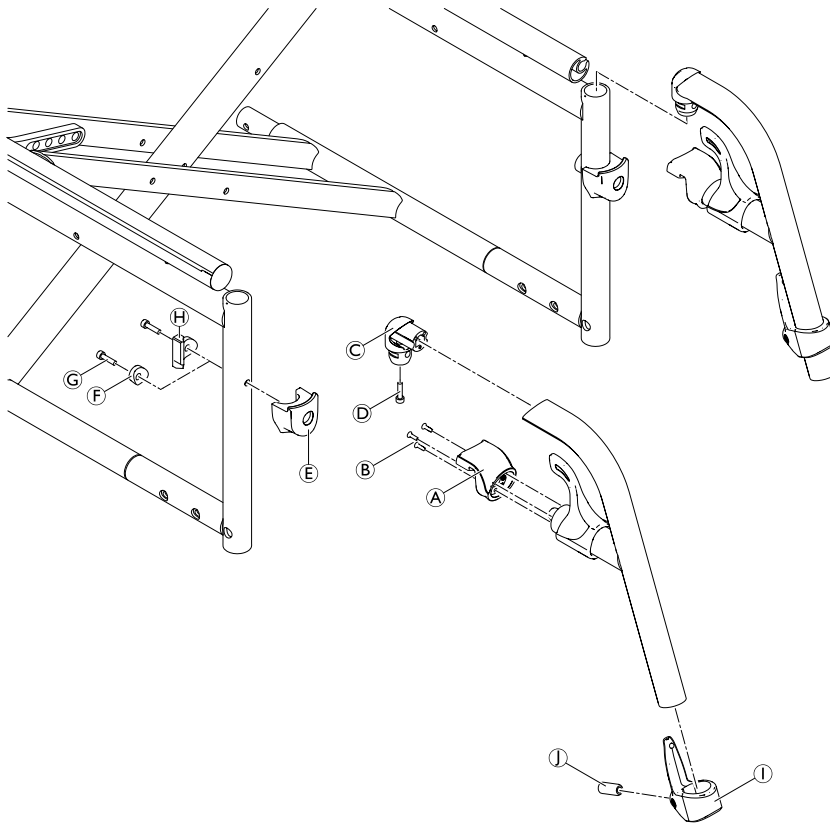

Ⓓ → 7 Nm

Ⓒ → 8 Nm

Replacing legrest parts

Replacing the locking mechanism on the legrest

Difficulty: ●○○

Tools: * 8

- Remove locking mechanism (A) by turning out screws (B) and replace with a new one.

Replacing the locking device on the frame

Difficulty: ●○○

Tools: ● 4

- Remove locking device (E) and fitting washer (F) respectively special washer (H) (for limitation of the pivot radius for the footrests) by turning out screw (C) and replace with new parts.

ⓘ Special washer (H) can be mounted in two positions (reversed left to right) for footrest pivot radii of 30° or 50°.

Replacing the footrest pivot

Difficulty: ●○○

Tools: ● 5

- Remove the footrest pivot (C) by turning out screw (D) and replace with a new one.

Replacing the calf strap support

Difficulty: ●○○

Tools: ● 5

- Remove calf strap support (I) by turning out resilient screw (J) and replace with a new one.



FOOTRESTS

Two-piece footrest

Difficulty: ●○○

Tools: ● 5

Disassembling/fitting footrests

- 1 Loosen bolts (A) on both sides.
- 2 Pull out footrests.
- 3 Push the new footplates into the legrest at the required height.
- 4 Tighten set screw (A) at the required height.

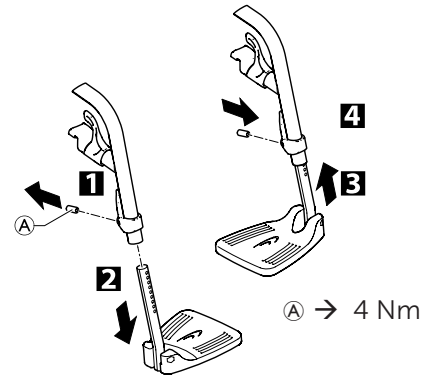

Adjusting the height of the footrests

Difficulty: ●○○

Tools: ● 5

- 1 Loosen bolts (A).
- 2 Push the footplates into the required position.
- 3 Tighten set screw (A) at the required height.

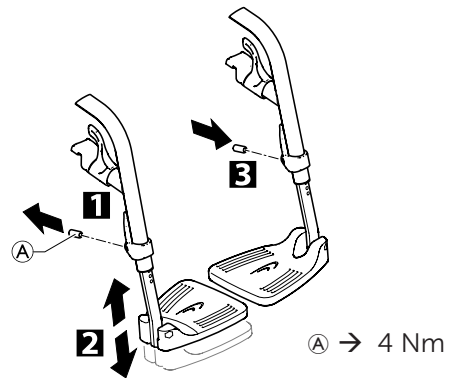

Changing the position of the footrests (set to rear – set to front)

Difficulty: ●○○

Tool: ● 5

- 1 Remove bolts (A).
- 2 Pull the footrests away downwards and replace.
- 3 Re-insert bolts (A) and tighten.

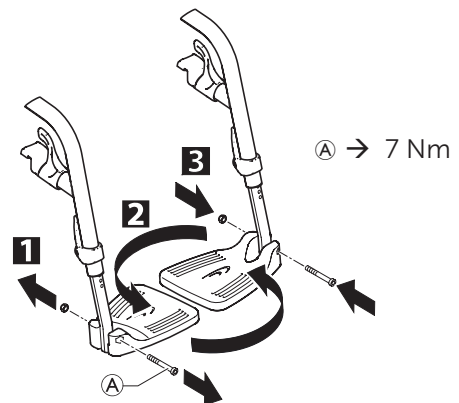

Two-piece footrest, adjustable-angle

Adjusting the angle and depth

Difficulty: ●○○

Tool: ● 5

- Loosen bolt (A).
- 1 Change the angle of the footrest until it reaches the required position.
- 2 Change the depth of the footrest until it reaches the required position.
- Retighten bolt (A).

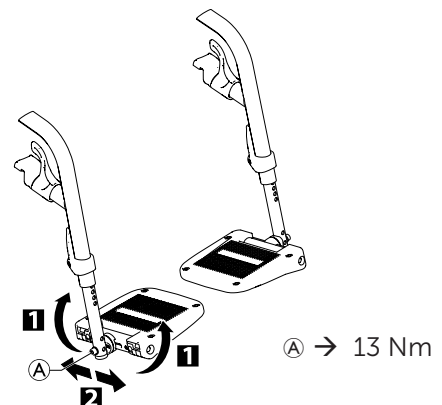



SIDEPARTS

Clothes guard/mudguard

Fitting the clothes guard/mudguard

Difficulty: ●●○

Tools: ● 3, 4 ○ 8

- Fit side fixations (A) onto the frame.
- Fit clothes guard/mudguard (B) with bolts and nuts onto the side fixations (4 Nm).



CAUTION!

Fit the mudguard such that it is positioned either < 8 mm or > 25 mm above the tyres, to avoid the risk of trapping one's fingers.

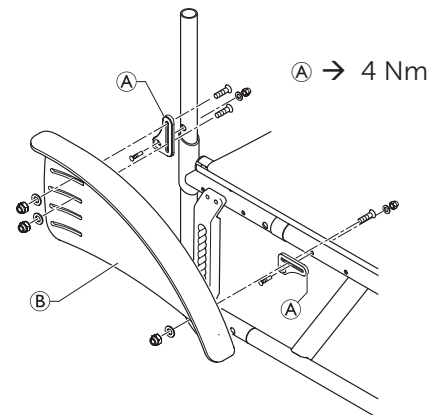

Adjusting the clothes guard/mudguard

Difficulty: ●●○

Tools: ● 3 ○ 8

- 1 Loosen bolts (A). Move the clothes guard/mudguard (B).
 - Retighten bolts (A).
- or
- 2 Loosen and remove bolts (A).
 - 3 Re-fit clothes guard/mudguard (B) in another position.

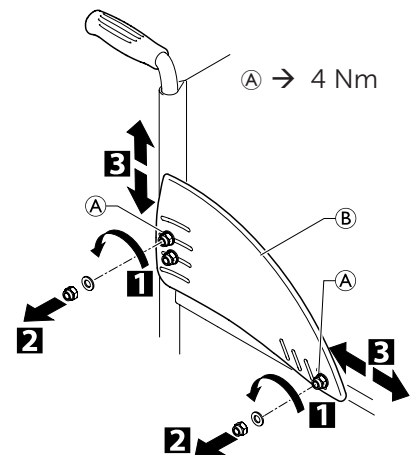

Fitting and adjusting the removable mudguard

Difficulty: ●●○

Tool: ● 3, 4, 5 ○ 10

- 1 Fit the mudguard adapter (A) with bolts (B1) and (B2).
- 2 Insert mudguard (C) in the mudguard adapter (A). Adjust the height by loosening the two bolts on the clamping part (D).
- 3 If the edge of the mudguard does not run evenly over the tyre, loosen bolts (E)/(F) and push the mudguard (C) into the required position. Retighten bolts (E)/(F).



CAUTION!

Fit the mudguard such that it is positioned either < 8 mm or > 25 mm above the tyres, to avoid the risk of trapping one's fingers.

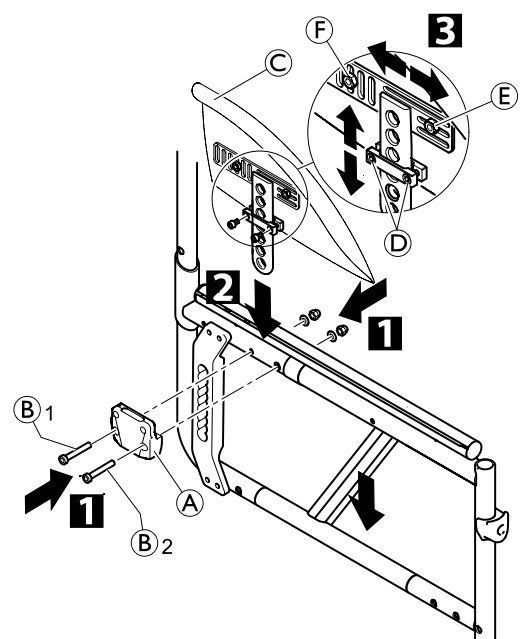

●B1 → 7 Nm

●B2 → 7 Nm

○E → 7 Nm

○F → 7 Nm



Siderests

In general a torque of 7 Nm is used to fit the side rests.

Fitting flip to back side rest with locking mechanism

Difficulty: ●●○

Tools: ● 3, 4, 5 ◻ 10

- Fit the side fastening element with bolt (A1).
- For bolt (A2), bore a hole with a diameter of 6 mm through the front frame (hole already made in the connecting tube) and fit bolt (A2).
- Screw the sleeve and bolt (B) onto the rear fastening element (C).
- Fit rear fastening element (C) and clip (G) loosely with bolts (H) and sleeves (I) (normal rear frame: 17 mm beneath the upper edge of the frame reinforcement, on a shortened rear frame, directly flush with the upper edge of the frame reinforcement).
- Mount side rest (D), position rear fastening element (C) precisely.
- Attach the wedge (E) and headless bolt (F).

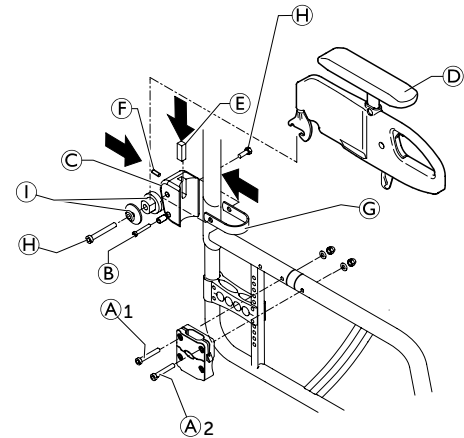

 The sleeves (I) are different for flip to back side rest with engagement mechanism.

 To enlarge the distance between the wheels additionally, a different adapter sleeve, which is mounted from the inside, has to be applied.

Fitting side rest insertable, continuously height-adjustable

Difficulty: ●●○

Tools: ● 4, 5 ◻ 10

- 1 Fit the side fastening element with bolts (A) and (B).
 - 2 Insert side rest into the fastening element.
- Adjust height by adjusting the clamp component.

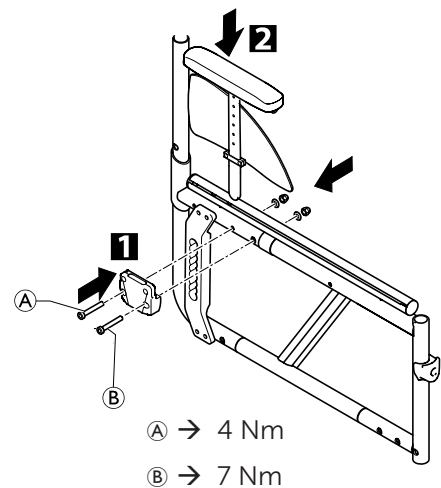

Installing the tubular armrest

Difficulty: ●●○

Tools: ◻, ● 4, 5

- Install the clamping pieces (A) around the frame (B) using screws (C).
- Install the armrest holder (D) to the clamping piece using screws and washers (E).
- Fix the armrest pad (G) to the tubular armrest (F) using screws (H).
- Place the covering cap (I) onto the end of the armrest tube.
- Insert the round nut (J) into the required position of the armrest tube and fix from both sides using screws (K).
- Place the armrest assembly into the armrest holder.

- C → 4 Nm
- E → 13 Nm
- H → 4 Nm
- K → 7 Nm (low strength)

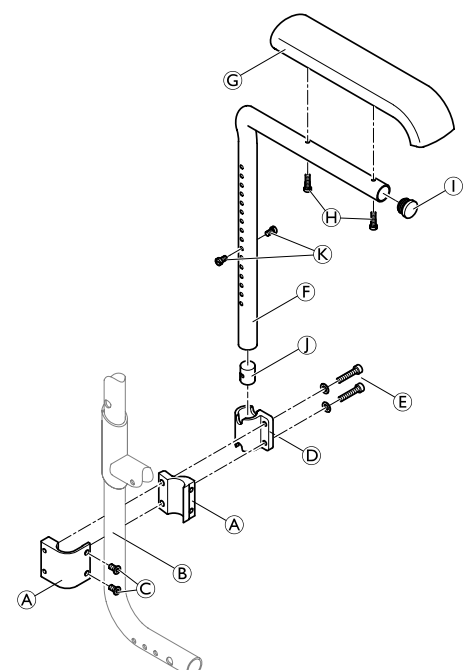



Size of the clothes guard/mudguard

The clothes guard and mudguard can be adjusted to suit the height of the rear wheel exactly. Two sizes of each are available. For the removable carbon mudguard there is an additional size (XL) for the two smallest rear seat heights (SHh).

Clothes guard mounted fix:

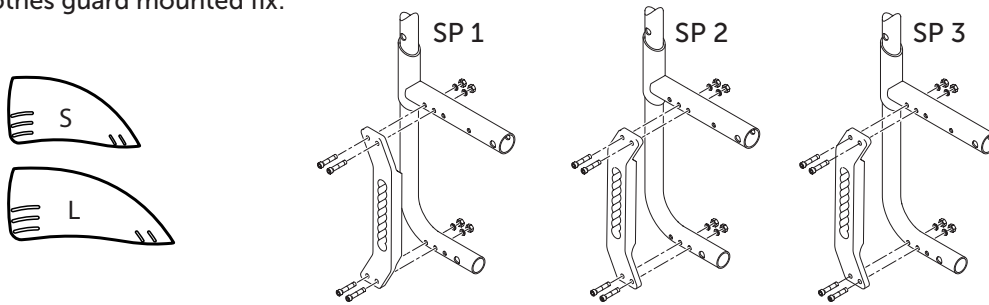

Clothes guard with respect to the position of the rear wheels with vertical brace (Pos. 1 to 3)

SHh [mm]	Rear wheel 24'		
	SP 1	SP 2	SP 3
400	L	L	L
410	L	L	L
420	L	L	L
430	L	L	S
440	L	S	S
450	L	S	S
460	S	S	S
470	S	S	S
480	S	S	S
490	S	S	S



Mudguard mounted fix:

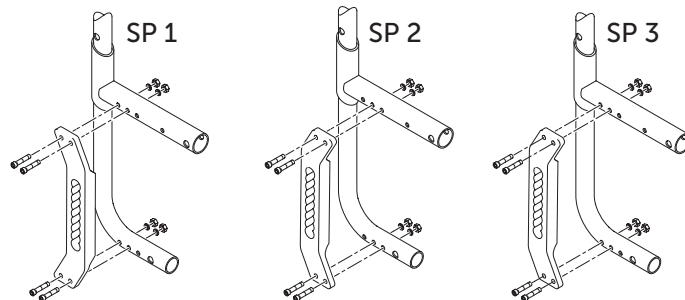
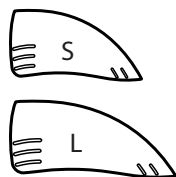

Mudguard (mounted fix) with respect to the position of the rear wheels with standard adapter plate (Pos. 1 to 3)

SHh [mm]	Rear wheel 24"		
	SP 1	SP 2	SP 3
410	L	L	L
420	L	L	L
430	L	L	S
440	L	S	S
450	L	S	S
460	L	S	S
470	S	S	S
480	S	S	S
490	S	S	S

Mudguard removable:

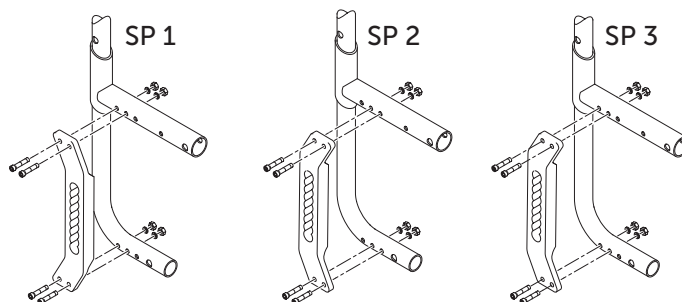
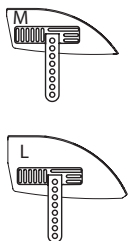

Mudguard (removable) with respect to the position of the rear wheels with standard adapter plate (Pos. 1 to 3)

SHh [mm]	Rear wheel 24"		
	SP 1	SP 2	SP 3
400	L	L	L
410	L	L	L
420	L	L	L
430	L	L	L
440	L	L	M
450	M	M	M
460	M	M	M
470	M	M	M
480	M	M	M
490	M	M	M



Fitting the küschall armrest

Mounting the armrest hardware

Difficulty: ●●●

Tools: ● 3, 4, 5 □ 10

- Insert nuts **C** and bolts **B** into the upper holes of the armrest holder **A** and carefully tighten. Do not squeeze the holder.
- Mount the armrest holder **A** to the rear frame hole **M** using bolt **F**, sleeve **E**, washer and nut **D**.
- Drill holes **N** with a diameter of 6 mm through the front frame by inserting the drill bit through the free hole of the pre-mounted armrest holder **A**.
- Insert bolt **H** and tighten with washer and nut **G**.
- Grease the pin **P** and Insert it with the spring **O** into the inner hole of clamping part **K** and place it around the reinforced part **L** of the rear frame.
- Place the mating clamping part **I** around the rear frame and fix in true alignment with washers and bolts **I**.

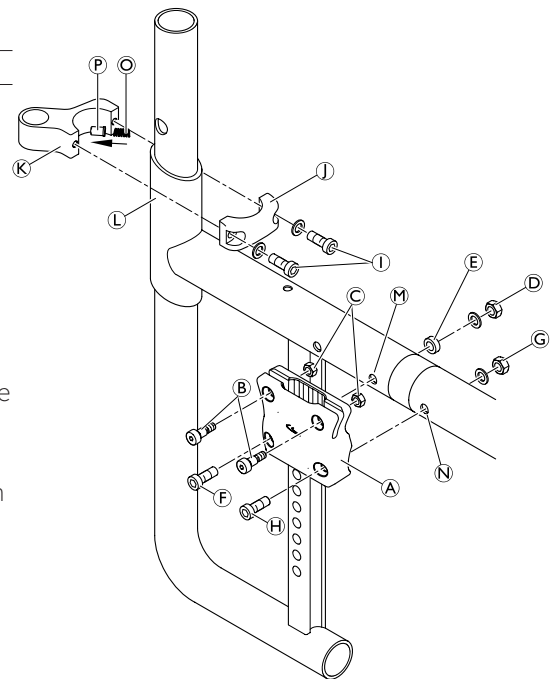

Installing/Removing the armrest, T-armrest pad and cover

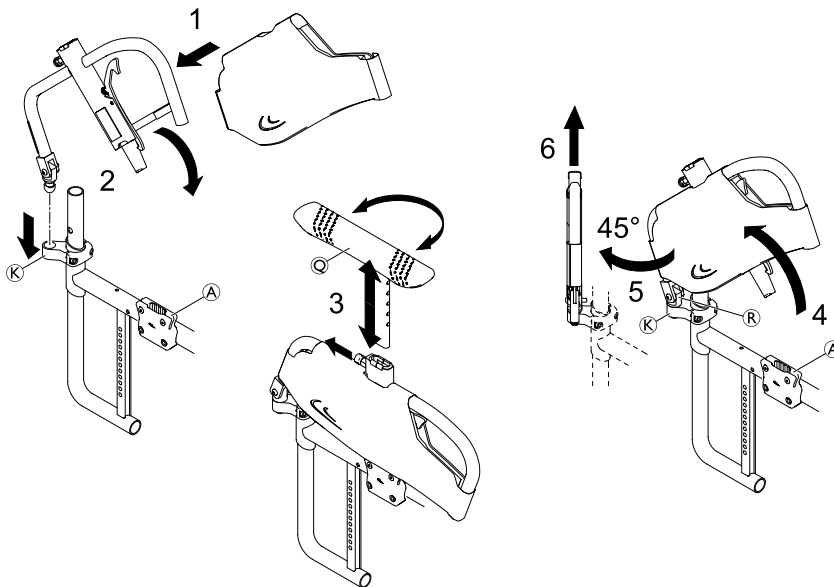

D → 7 Nm

G → 7 Nm

I → 4 Nm

Installing

- 1** Install the armrest cover to the armrest assembly.
- 2** Insert the armrest assembly into the joint **K** and swivel it downwards so that it engages into the armrest holder **A**.
- 3** Install the T-armrest pad **Q** to the armrest assembly.

Removing

- 3** Remove the T-armrest pad from the armrest assembly.
- 4** Swivel the armrest assembly upwards out of the armrest holder **A**.

I On the backside of the joint pin **R** there is a tapped hole with a M5 stop screw **S** to define the stop of the armrest assembly when swivelling backwards. Adjust the stop screw as required.

- 5** Swivel the armrest assembly 45° outwards.

- 6** Lift the armrest assembly out of joint **K**.

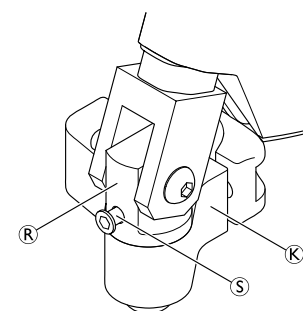



FRONT WHEELS

Replacing a front wheel

Difficulty: ●○○

Tools: ● 3

- 1 Remove the screw (A) with washer on one side. Remove the wheel axle (B).
- 2 Remove the front wheel (C).
- If needed, place the sleeves (D) between the new front wheel and the fork.
- 3 Slide the axle (B) through the fork, sleeves (D) and the front wheel (C) and fix the axle using the screw (A). Here, use the new screw supplied with the wheel as this screw comes with thread-lock applied.

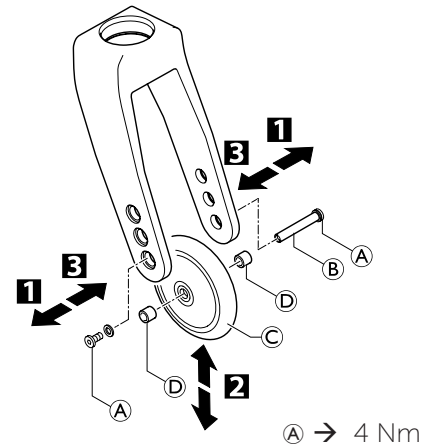

Function check:

The wheel must not wobble, but must rotate easily.

Front wheel fork

Replacing the front wheel fork

Difficulty: ●●○

Tools: ● 3 □ 10

- 1 Remove bolts (A), wheel axle (B) and front wheel (C).
- 2 Remove screw (D) and washer (E) and pull the front wheel fork (F) from the front wheel pin.
- Replace front wheel fork (F) and secure with screw (D) and washer (E) such that the fork has no play.
- Re-insert the front wheel.



CAUTION!

Do not overtighten screw (D), as this can damage the bearings.

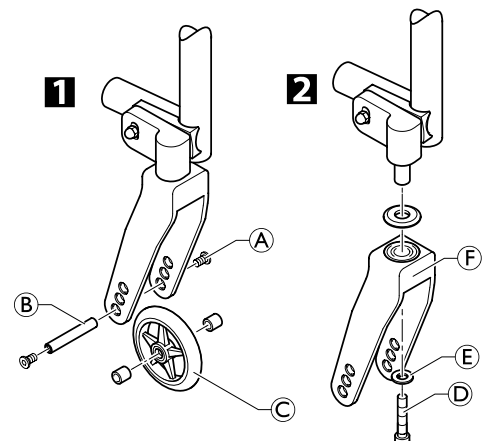

Function check

Tip the wheelchair backwards by 90° so that it is lying on the backrest and the rear wheels. Make sure that the clevis pin is as horizontal as possible. Turn the fork upwards (position A) and let it tip downwards.

The fork has been correctly adjusted if it easily turns to slightly beyond the bottommost point (position B) and then maximally turns back to the bottommost point (position C).

If the fork turns back over the bottommost point or even swings back and forth, it has not been sufficiently tightened. There is a risk that the front wheels will start to wobble at high speeds.

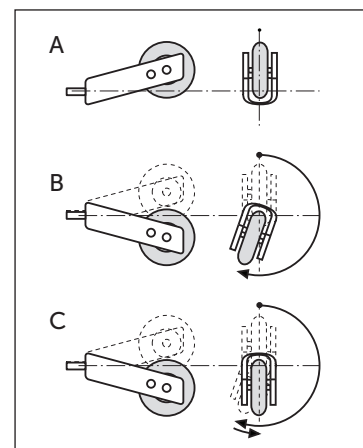



Adjusting the front wheel angle

Difficulty: ●●○

Tools: ● 3, 5 ⬡ 10

- Loosen bolts (A) and nuts (B).
- Hold spirit level against the front wheel pin housing (D).
- Turn the set screw (C) until the front wheel pin housing is (D) vertical.
- Retighten bolts (A) and nuts (B).



CAUTION!

It is important that the settings on the left and right are precisely the same.

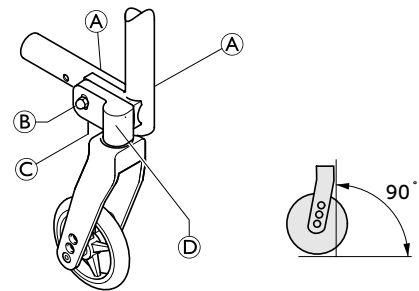

(A) → 13 Nm

Adjusting the trial angle

Difficulty: ●●○

Tools: ● 5 ⬡ 10

- Loosen bolts (A) and nuts (B).
- Remove front wheel pin housing (E).
- Attach adjustment template (C)/(D) (for toe-out: insert template at the bottom (C), for toe-in: insert template at the top (D)).
- Fit front wheel pin housing (E).
- Set the angle, → Chap. Front wheels; Adjusting the front wheel angle.

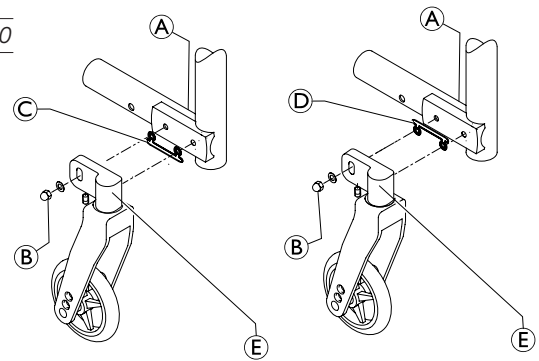

Special housing guides

Fitting special housing guide for smaller SHv (housing guide, fitted high)

Difficulty: ●●○

Tools: ● 5 ⬡ 10

- Remove front wheel pin housing (B).
- Remove standard housing guide.
- Attach bolt (C).
- Fit special housing guide (A) high.
- Fit front wheel pin housing (B).
- Set the angle, → Chap. Front wheels; Adjusting the front wheel angle, Adjusting the trial angle.

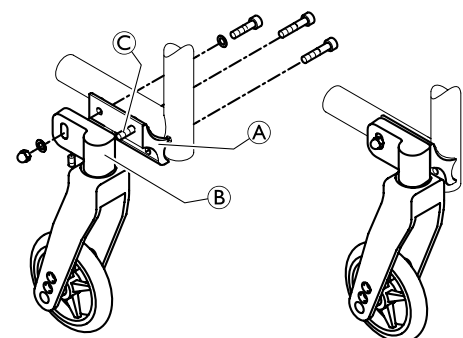

(A) → 13 Nm

(B) → 13 Nm



REAR WHEELS

Adjusting the seat height rear

Difficulty: ●○○

Tools: ☰ 19, 22

- Remove adapter sleeve ②.
- Re-insert adapter sleeve ② at the required height in the vertical brace ① and fasten securely with nut ③.
- Perform the same setting on both sides.

i After the SHh is changed, the front wheel angel must be checked → Chap. Front wheels; Adjusting the front wheel angel, Adjusting the trial angel.
And with a wheel camber of 3° the angle of the rear wheels must also be checked, → Chap. Rear wheels; Changing the wheel camber.

i After the SHh is changed, distance sleeves may also have to be fitted in order to increase the distance to the rear wheels.

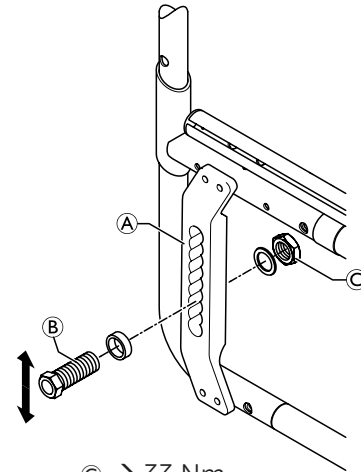

③ → 33 Nm

Tipping stability

The tipping stability is influenced by the vertical brace ① being fitted further forward or further backward on the frame. The further back the vertical brace is fitted, the greater the tipping stability of the wheelchair.

There are 3 different positions the vertical brace can be mounted on the frame:

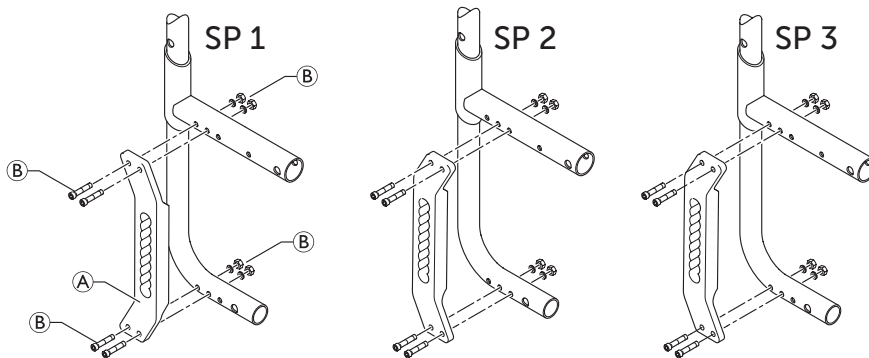

② → 6 Nm

Adjusting the position of the vertical brace on the frame

Difficulty: ●○○

Tools: ● 4 ☰ 10

- 1 Remove the vertical brace ① by removing screw connections ②.
 - 2 Re-attach the vertical brace ① at one of the four positions in the frame holes using screw connections ② and tighten.
- Perform the same setting on both sides.

i Brakes and mudguard must be repositioned if the position of the rear wheel is changed.



Wheel camber

A wheel camber of either 0° or 3° is possible.

Changing the wheel camber

Difficulty: ●●○

Tools: **C** 18 19, 22

The wheel camber is changed by replacing the adapter sleeve:

- 1 Remove adapter sleeves **B** or **C** on both sides.
- 2 Insert new adapter sleeves **C** and **B** on both sides at the required, identical position in the vertical brace **A** and fasten securely with nut **D**.

Ensuring the rear wheels are parallel

Difficulty: ●●●

Tools: **C** 18 19, 22

- Loosen nuts **D** of adapter sleeves **C** on both sides.
- At the height of the center of the axle, measure the distance between the rear wheels at the front and back (x, y).

Distance, back > distance, front	Turn adapter sleeve towards rear (viewed from above)
Distance, front > distance, back	Turn adapter sleeve towards front (viewed from above)

- In accordance with the table, turn the adapter sleeves so that the distance between the rear wheels is the same at the front and the back (x = y) – measured at the height of the center of the axle.

At the same time, the distance between the individual wheels and the relevant side frame can be checked for conformity and adjusted if necessary.

- Retighten nuts **D** of adapter sleeves **C** on both sides.

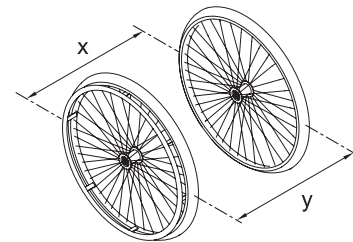
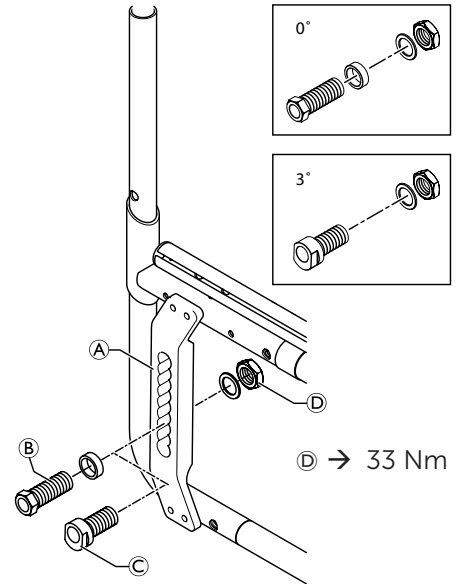

Adjusting the removable axle

Difficulty: ●●○

Tools: **C** 11, 19

- Remove the rear wheel.
- Hold the end of the removable axle **B** using the open-end spanner.
- Adjust the length L of the removable axle by turning the nut **A**. The length is correctly adjusted if the removable axle engages correctly when fixing the wheel and wheel has just minimal clearance.

The wheels must be exchanged (left to right side and vice versa) after adjusting both removable axles. The adjustment must now be checked or carried out again to ensure the wheels can be switched.

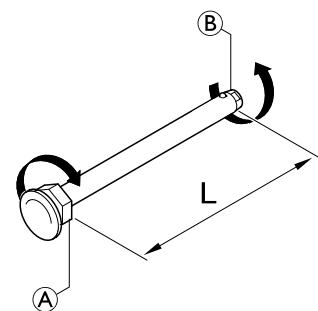



Repairing or changing an inner tube

Difficulty: ●○○

Tool: tire lever

- Remove the rear wheel and release any air from the inner tube.
- Lift one tire wall away from the rim using a bicycle tire lever. Do not use sharp objects such as a screwdriver which could damage the inner tube.
- Pull the inner tube out of the tire
- Repair the inner tube using a bicycle repair kit or, if necessary, replace the tube.
- Inflate the tube slightly until it becomes round.
- Insert the valve into the valve hole on the rim and place the tube inside the tire (the tube must lie right round the tire with no creases).
- Starting close to the valve, push the tire wall over the edge of the rim using both hands. When doing this, check all the way round to ensure that the inner tube is not trapped between the tire and the rim.
- Inflate the tube to its maximum operating pressure, → Table, chap. Rear wheels, Checking the tire pressure. Check that no air is escaping from the tire.

Repairing or changing a solid tire

Solid tires must be fitted by a qualified technician.



BRAKES

Parking brakes

Mounting the parking brake

Difficulty: ●○○

Tools: ● 5

- Position the brake holder (B) around the front frame tube (C).
- Place the brake (D) in the brake holder.
- Screw the bolt (A) with washer (C) into the brake assembly but do not tighten.
- Rotate the brake holder assembly around the frame tube to adjust the lateral distance of the brake.
- Rotate the brake in the brake holder to achieve a horizontal position of the brake rod (E) to the tire.
- Fully apply the brake and slide it towards the tire until the brake rod bears flush against the tire.
- Release the brake and slide it 3 mm backwards and tighten the bolt.

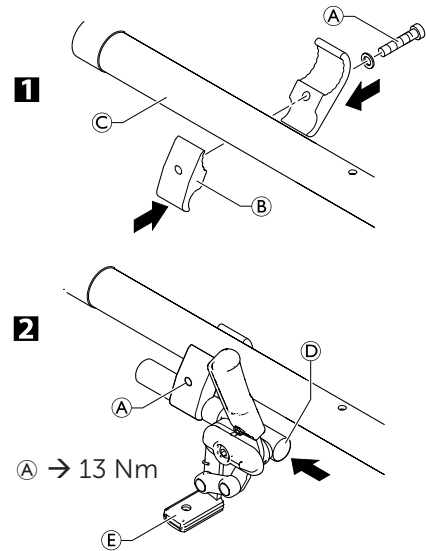

Adjusting the parking brake

Difficulty: ●○○

Tools: ● 5



WARNING!

The parking brakes must be readjusted whenever the rear wheels are replaced or the wheel camber is changed.

The parking brake function is only guaranteed if the tire has the corresponding air pressure.

- Check the tire pressure in the rear wheels and correct if necessary.
- Slightly loosen bolt (A) of the brake holder.
- Change the position of the brake assembly as described above.
- Tighten the bolt.



IMPORTANT!

The force to apply the brake must be 60 N (maximum).



Very little force is required for activating and deactivating the brake. If necessary, a brake lever extension can be mounted.

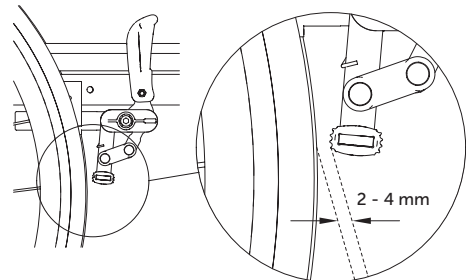

Visual check

Check that the parking brakes are positioned correctly. The brake is set correctly if the brake rod depresses the tire by no more than 4 mm when the brake is applied. (In the case of push/pull and standard brakes this will be the case when the brake shoe is approx. 2 - 4 mm away from the tire when released.)

Function check

Place a weighted wheelchair with parking brake engaged facing uphill and then facing downhill on a ramp with an incline of 7°. The wheelchair must not move.



Drum brake

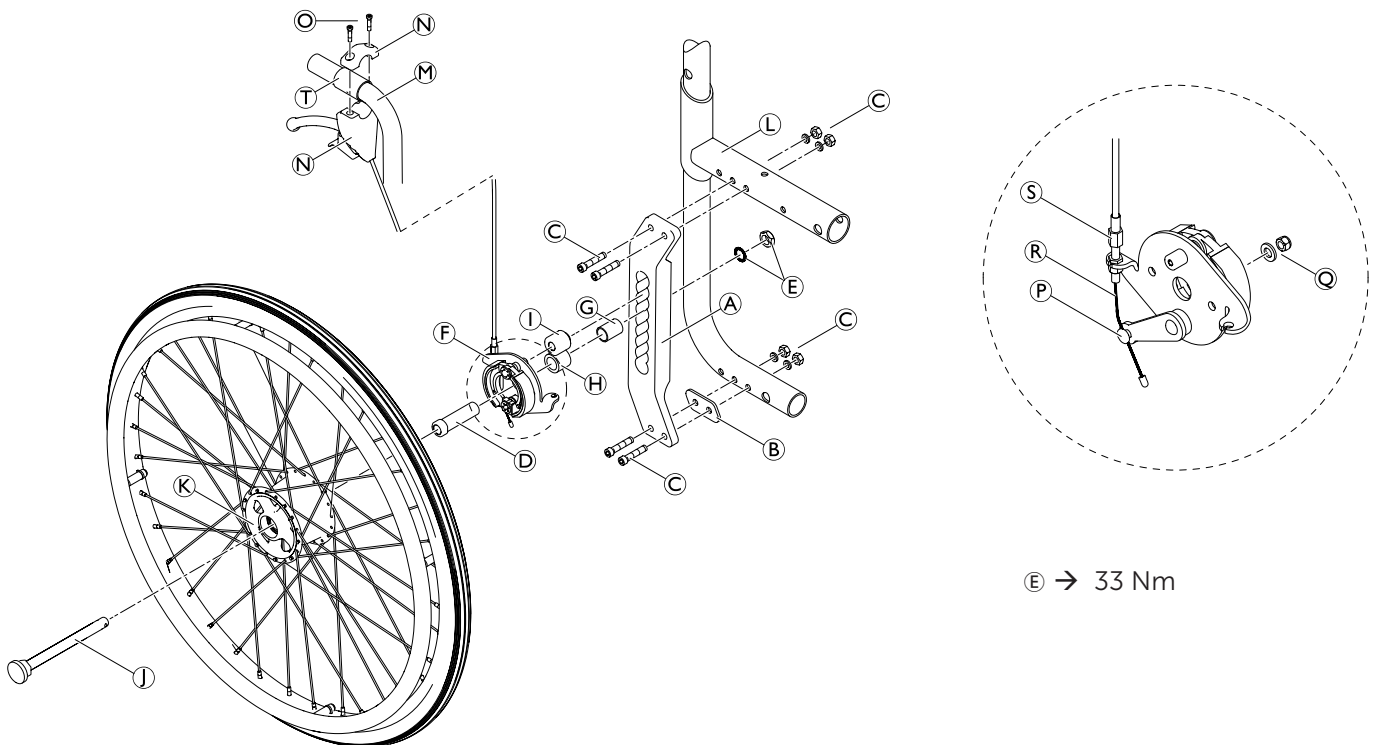

Ⓔ → 33 Nm

Fitting and setting the drum brake

Difficulty: ●●●

Tools: ● 4 — C 8, 17 ⬡ 10, 22, * 20

- Remove the rear wheel **K** by loosening the quick release axle pin **J**.
- Remove the adapter sleeve **D** by loosening locknut and washer **E**.
- Remove vertical brace **A** from the frame **L** by loosening bolt connections **C**.
- Place distance part **B** between vertical brace and lower frame tube and fix again with bolt connections **C**.
- Attach the torque support **I** to the pin of the brake shoe support **F**.
- Insert aluminum sleeve **G** into the vertical brace at the desired height.
- Mount the brake shoe support **F** with distance sleeves **H** through the aluminum sleeve **G** to the vertical brace using adapter sleeve **D** and locknut with washer **E**.

! IMPORTANT!
Make sure that the torque support **I** sits in the next but one hole of the vertical brace, secured with the pin of the brake shoe support from the other side.

- Attach the rear wheel with the quick release axle.
- Fit brake lever **N** on the push handle tube **M** using sleeve **T** and screws **O**.
- Secure the cable **R** to the brake shoe support lever by tightening the cable bolt **P** with washer and nut **Q**.
- Adjust the cable tension to the desired brake effort by screw/unscrew the tensional bolt **S**.
- Secure the tensional bolt with the locknut.
- Carry out the same setting on both sides.

! IMPORTANT!
Make sure that the cable adjustment has the same brake effect on both sides.



OPTIONS & ACCESSORIES

Antitipper

Fitting an antitipper

Difficulty: ●○○

Tool: ● 5, 3

- Fix the adapter plates **C** and **D** with bolts **E** onto the frame tube.
- Attach the adaptation support **A** with bolts **B** through the adapter plates and on the frame tube, move to the correct height and align and tighten bolts **B**.

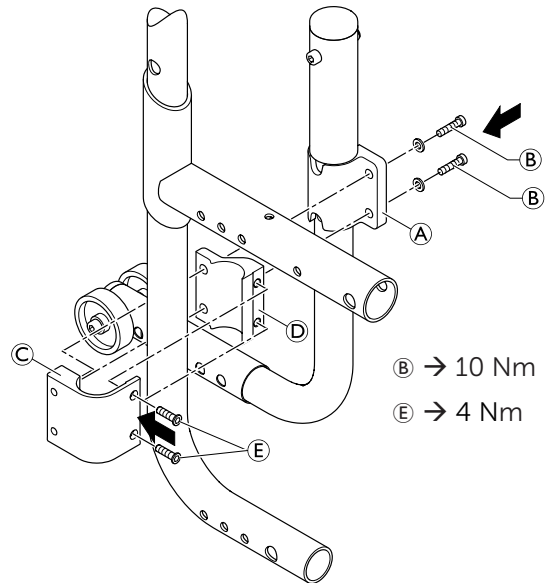

B → 10 Nm
E → 4 Nm

Adjusting the height of the antitipper

The height can be adjusted by loosening bolts **B** like described above. If this is not sufficient proceed as follows:

Difficulty: ●○○

Tool: ● 3, 4 ◻ 8, Needle-nosed pliers

- 1** Loosen bolt **B** and remove the upper end **C** of the antitipper and the holder. Remove the sealing cap **A** (e.g. push it out through the tube using the screwdriver).
 - 2** Loosen bolt **G** of the antitipper tube and push sleeve **F** into the correct position.
 - 3** Screw bolt **G** in half way, position spring **H** in sleeve **F** and screw bolt **G** completely into the tube.
 - 4** Put all the parts of the antitipper back together; in doing so pull spring **H** apart, e.g. using a wire hook, and secure it with the top bolt **B**.
- Set the antitipper parallel to the wheelchair and tighten the bolts.

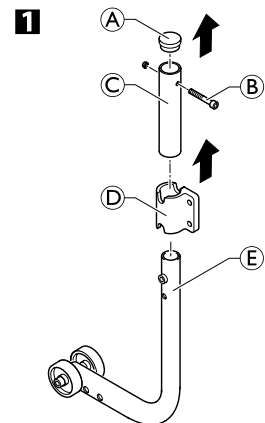

B → 4 Nm
G → 7 Nm

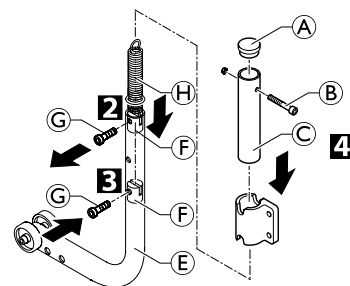

Function check:

The distance between the antitipper and the ground must be 50 - 70 mm. It must be easy to fold up the antitipper.

Tip the wheelchair backwards using the antitipper until the axle is perpendicular to the antitipper's point of contact with the ground. In this position, the distance between the rear wheel and the ground must be at least 50 mm.

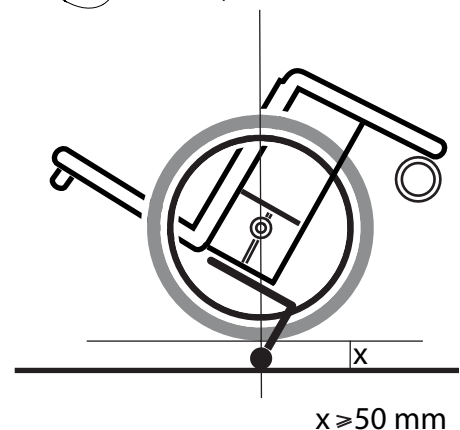

$x \geq 50 \text{ mm}$



Tipper aid/Cane holder

Tipper aid and cane holder are mounted in the same way.

Fitting the tipper aid/cane holder

Difficulty: ●○○

Tool: ● 5, 3

- Fix the adapter plates **C** and **D** with bolts **E** onto the frame tube.
- Attach the adaptation support **A** with bolts **B** through the adapter plates and on the frame tube, move to the correct height and tighten.
- Push in spring clip **G** and push the tipper aid **F** or the cane holder **I** into the adaptation support.
- Make sure that the spring clip is correctly engaged in the adaptation support.

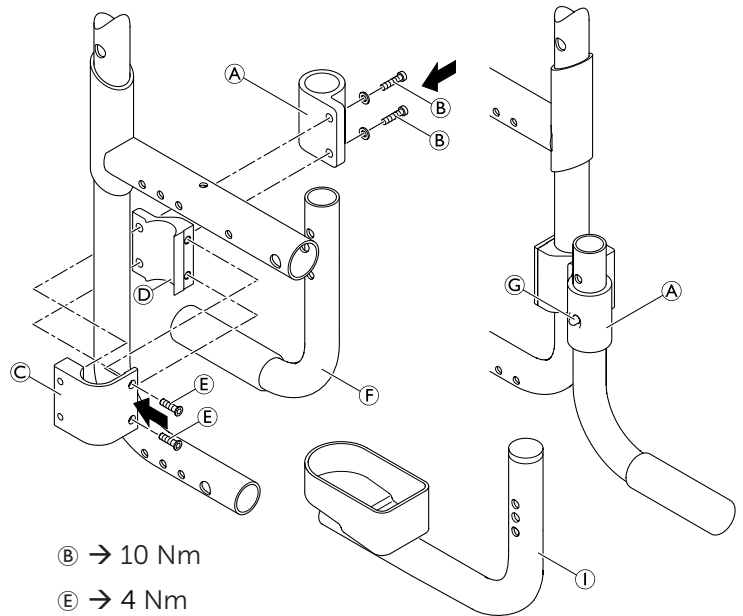

Adjusting the height of the tipper aid/ cane holder

Difficulty: ●○○

- To adjust the height, remove cap **H** and, e.g. using a screwdriver, compress the spring **G** inside the tube and push into the required position.

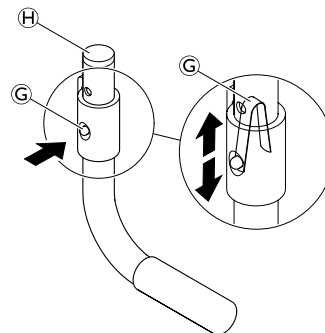

CAUTION!

The height of the tipper aid, measured from the upper part of the device to the ground, must be less than 175 mm.
 The distance between the center of the tipper aid device and the inner side of the nearest rear wheel must be larger than 50 mm.



Fitting the posture belt

Difficulty: ●○○

Tools: ● 5 ◻ 10

- Attach the vertical brace (F) to the frame (B) with steel strap (A), washer (D) and distance part (E) between using bolts (C) on both sides.



Ensure that the webbing of the posture belt is not twisted during assembly and the locking mechanism shows towards the front.

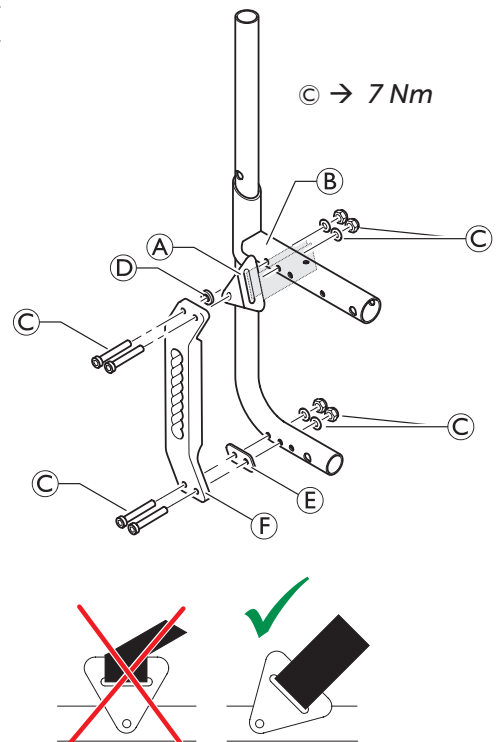

Attaching the snap hook symbols

Front side

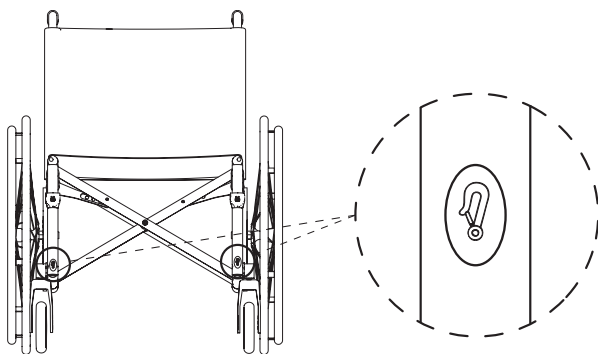

Rear side

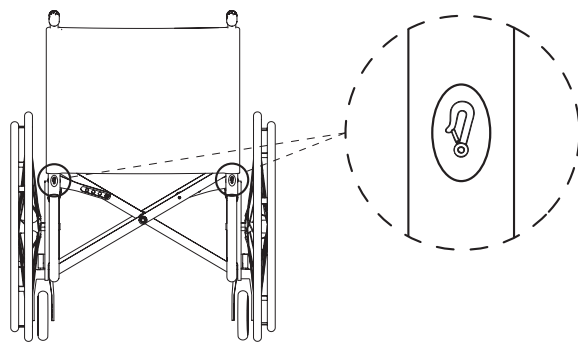



Invacare France Operations
Route de St Roch
F-37230 Fondettes
France

Service Manual
KÜSCHALL COMPACT^{attract}
ENGLISH | 2018-07

Invacare distributors:

Belgium & Luxemburg: Invacare nv • Autobaan 22 • B-8210 Loppem

Tel: (32) (0)50 83 10 10 • Fax: (32) (0)50 83 10 11 • belgium@invacare.com • www.invacare.be

Danmark: Invacare A/S • Sdr. Ringvej 37 • DK-2605 Brøndby

Tel: (45) (0)36 90 00 00 • Fax: (45) (0)36 90 00 01 • denmark@invacare.com • www.invacare.dk

Deutschland: Invacare GmbH • Alemannenstraße 10 • D-88316 Isny

Tel: (49) (0)75 62 7 00 0 • Fax: (49) (0)75 62 7 00 66 • kontakt@invacare.com • www.invacare.de

Eastern Europe, Middle East & CIS: Invacare EU Export • Kleiststraße 49 • D-32457 Porta Westfalica

Tel: (49) (0)57 31 754 540 • Fax: (49) (0)57 31 754 541 • webinfo-eu-export@invacare.com • www.invacare-eu-export.com

España: Invacare SA • c/Areny s/n • Poligon Industrial de Celrà • E-17460 Celrà (Girona)

Tel: (34) (0)972 49 32 00 • Fax: (34) (0)972 49 32 20 • contactsp@invacare.com • www.invacare.es

France: Invacare Poirier SAS • Route de St Roch • F-37230 Fondettes

Tel: (33) (0)2 47 62 64 66 • Fax: (33) (0)2 47 42 12 24 • contactfr@invacare.com • www.invacare.fr

Ireland: Invacare Ireland Ltd • Unit 5 Seatown Business Campus • Seatown Road • Swords • County Dublin – Ireland

Tel : (353) 1 810 7084 • Fax: (353) 1 810 7085 • ireland@invacare.com • www.invacare.ie

Italia: Invacare Mecc San s.r.l. • Via dei Pini 62 • I-36016 Thiene (VI)

Tel: (39) 0445 38 00 59 • Fax: (39) 0445 38 00 34 • italia@invacare.com • www.invacare.it

Nederland: Invacare BV • Galvanistraat 14-3 • NL-6716 AE Ede

Tel: (31) (0)318 695 757 • Fax: (31) (0)318 695 758 • nederland@invacare.com • www.invacare.nl

Norge: Invacare AS • Grensesvingen 9 • Postboks 6230 • Etterstad • N-0603 Oslo

Tel: (47) (0)22 57 95 00 • Fax: (47) (0)22 57 95 01 • norway@invacare.com • island@invacare.com • www.invacare.no

Österreich: Invacare Austria GmbH • Herzog Odilostrasse 101 • A-5310 Mondsee

Tel.: (43) 6232 5535 0 • Fax.: (43) 6232 5535 4 • info@invacare-austria.com • www.invacare.at

Portugal: Invacare Lda • Rua Estrada Velha • 949 • P-4465-784 Leça do Balio

Tel: (351) (0)225 1059 46/47 • Fax: (351) (0)225 1057 39 • portugal@invacare.com • www.invacare.pt

Sverige: Invacare AB • Fagerstagatan 9 • S-163 91 Spånga

Tel: (46) (0)8 761 70 90 • Fax: (46) (0)8 761 81 08 • sweden@invacare.com • finland@invacare.com • www.invacare.se

Suomi: Camp Mobility • Patamäenkatu 5 • 33900 Tampere

Tel: 09-35076310 • info@campmobility.fi • www.campmobility.fi

Schweiz/Suisse/Svizzera: Invacare AG • Benkenstrasse 260 • CH-4108 Witterswil

Tel.: (41) (0)61 487 70 80 • Fax.: (41) (0)61 487 70 81 • switzerland@invacare.com • www.invacare.ch

United Kingdom: Invacare Limited • Pencoed Technology Park,

Pencoed, Bridgend CF35 5AQ • Switchboard Tel: (44) (0)1656 776 200, Fax: (44) (0)1656 776 201 •

Customer services Tel: (44) (0) 1656 776 222 • Fax: (44) (0) 1656 776 220 • UK@invacare.com • www.invacare.co.uk

Australia: Invacare Australia Pty Ltd • ABN 45 074 676 378, PO Box 5002, 1 Lenton Place, North Rocks, NSW 2151, Australia •

Freephone: 1800 069 042, Fax: 02 8839 5353 • E-mail: sales@invacare.com.au • Web: www.invacare.com.au

New Zealand: Invacare New Zealand • PO Box 62-124, 4 Westfield Place, Mt. Wellington, Auckland, New Zealand •

Freephone: 8000 468 222, Freefax: 0800 807 788 • E-mail: sales@invacare.co.nz • Web: www.invacare.co.nz