

# KÜSCHALL K-SERIES *attract*



©2018 Invacare Corporation

All rights reserved. Republication, duplication or modification in whole or in part is prohibited without prior written permission from Invacare Corporation. Trademarks are identified by <sup>TM</sup> and <sup>®</sup>.  
All trademarks are owned by or licensed to Invacare Corporation or its subsidiaries unless otherwise noted.



## TABLE OF CONTENTS

<b>GENERAL</b> .....	<b>5</b>
Introduction	5
Spare parts and adaptations	5
Tightening Allen screws	5
Torque	6
Checks	6
Identifying and alleviating malfunctions	6
<b>OVERVIEW</b> .....	<b>7</b>
Components	7
Dimensions	7
<b>FRAME</b> .....	<b>8</b>
<b>SEAT</b> .....	<b>9</b>
Seat width (SB)	9
Seat depth (ST)	9
Front seat height (SHv)	9
Rear seat height (SHh)	11
Seat angle (SW)	11
Tipping point adjustment	12
<b>BACKREST</b> .....	<b>13</b>
Backrest height (RH)	14
Adjusting the backrest height	14
Securing/adjusting the release cord	14
Replacing the backrest tube	15
Replacing the handle	16
Replacing foldable push handles	16
Backrest angle (RW)	17
<b>FOOTRESTS</b> .....	<b>18</b>
Lower leg length (UL)	18
Replacing footrests	18
Adjusting the footrest height	18
Assembling the foot plate cover	18
Replacing the footplate support	18
Angle-adjustable footplate, adjusting the angle	19
Fitting and adjusting high-mounted footrest	19
<b>SIDE PARTS</b> .....	<b>20</b>
Clothes-guard/mudguard	21
<b>FRONT WHEELS</b> .....	<b>23</b>
Replacing a front wheel	23
Replacing a front wheel fork	23
<b>REAR WHEELS</b> .....	<b>24</b>
Ensuring the rear wheels are parallel	24
Adjusting the removable axle	24
Changing the wheel camber	24
Repairing or changing an inner tube	25
Repairing or changing a solid tire	25



---

<b>BRAKES</b> .....	<b>26</b>
Parking brakes	26
<b>OPTIONS &amp; ACCESSORIES</b> .....	<b>27</b>
Antitipper	27
Tipper aid	28
Mounting the posture belt	29
Attaching the snap hook symbols	29



## GENERAL

### Introduction

This service manual is part of the instructions and contains the technical information for servicing, configuring and repairing a küschall® wheelchair.



**WARNING!**

**Danger of accident and severe injuries.**

**If the wheelchair is improperly set it can cause accidents and severe injuries.**

- **Changes to the wheelchair may only be carried out by the provider.**

To guarantee the required safety and reliability, all wheelchairs must be comprehensively checked once a year.

In part, assembly and adjustment require extensive experience. For this reason, the following assembly instructions have been split into three categories:

Requirement	Symbol
Easy – technical understanding required	●○○
Intermediate – specialist knowledge required	●●○
Difficult – specialist wheelchair assembly knowledge and experience required	●●●

The required tools and their respective sizes are listed above each instruction. The instructions include information on the torques with which the respective screw connections must be tightened. Adhering to the given torques requires the use of a torque spanner.

Tools	Symbol
Allen key	◆ 3, 4, 5
Phillips screwdriver	✕ 2
Straddle spanner	—C 10, 11, 19
Socket spanner/ring spanner	⬡ 8, 10

### Spare parts and adaptations

All spare parts can be purchased from Invacare Customer Services. An electronic spare parts catalog is available by logging onto [www.kuschall.com](http://www.kuschall.com). Only original spare parts may be used. Installing additional adaptations to a küschall® wheelchair requires the prior written approval of the Invacare Corporation.

### Tightening Allen screws

Allen keys are not designed for greater forces. When tightening or loosening an Allen screw, it is therefore advisable to apply force to the nut to prevent the hexagon socket from being damaged.

### Tightening and loosening

- Turn the nut with a socket spanner (only use a straddle spanner if there is insufficient space) and merely hold the screw tight with the Allen key.

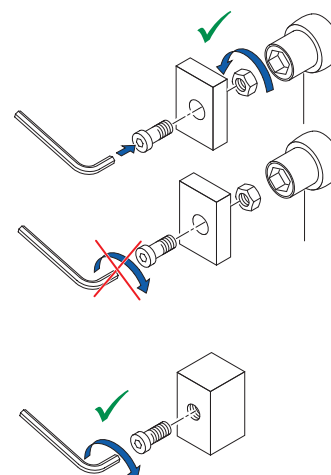



## Tightening and loosening if there is no nut

If an Allen screw is directly screwed into a screw thread, the screw must be tightened using an Allen key.

 Ensure that the Allen key is of good quality and not worn.

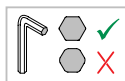

## Torque

■ All screw connections must be tightened with the torques specified in the following instructions.

## Checks

### Visual check

■ Check all components for cracks, especially the areas around joints and welded seams.

### Checking the screw connections

■ Check all bolts with the torques specified in the instructions regularly, and adjust if required.



### CAUTION!

Several screw connections have been secured with thread locking adhesive. If these are opened, they must be secured again using new thread locking adhesive.

Liquid high-strength and low-strength adhesives are available. For torque entries notice shall be made whether an adhesive and which adhesive needs to be used.

## Identifying and alleviating malfunctions

Malfunction	Possible cause	Measure
The wheelchair will not move in a straight line	Incorrect tire pressure in a rear wheel	Correct tire pressure
	One or more spokes broken	Replace defective spoke(s)
	Spoke unevenly tensioned	Tighten excessively loose spokes
	Dirty or damaged wheel bearings	Clean or replace bearings
The wheelchair tips backwards too easily	Rear wheels have been fitted too far forward	Fit rear wheels further back
	Backrest angle too great	Reduce backrest angle
	Seat angle too great	Use longer vertical struts
The brakes engage poorly or asymmetrically	Incorrect tire pressure in one or both rear wheels	Correct tire pressure
	Brake setting incorrect	Correct brake setting
Roll resistance is too great	Insufficient tire pressure in the rear wheels	Correct tire pressure
	Rear wheels are not parallel	Ensure that the rear wheels are parallel
The front wheels wobble when moving fast	Insufficient tension in the front wheel bearings block	Lightly tighten the nut in the bearings block axle
	Front wheel is worn flat	Replace front wheel
The front wheel is stiff or stuck	Dirty or damaged bearings	Clean or replace the bearings
Increased forward tip tendency	Frame deformed	Replace frame



## OVERVIEW

### Components

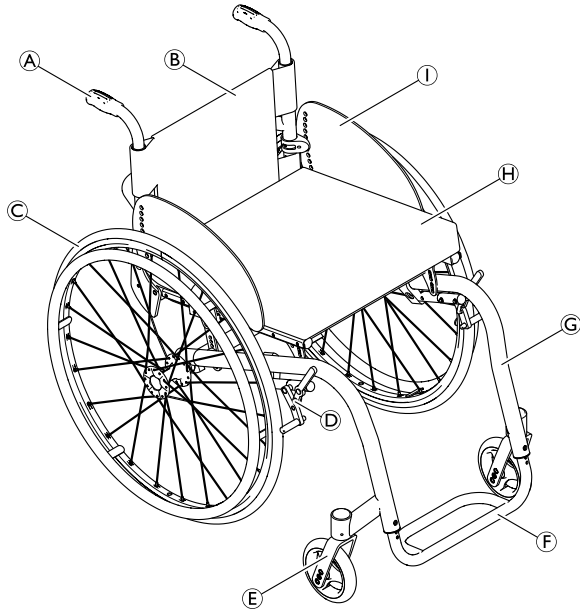

(A)	Backrest
(B)	Rear wheel with handrim
(C)	Quick release axle
(D)	Folding mechanism
(E)	Front wheel fork with front wheel
(F)	Footrest
(G)	Frame
(H)	Seat
(I)	Mudguard

### Dimensions

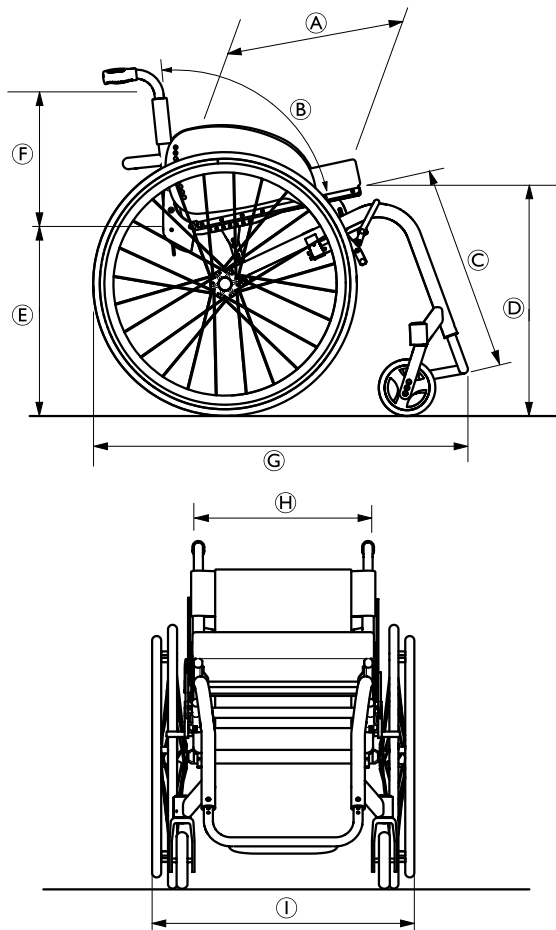

(A)	Seat depth	375 – 475 mm, in increments of 25 mm)
(B)	Backrest angle	78°/82°/86°/90°/94°
(C)	Knee-to-heel length	400 – 480 mm, in increments of 10 mm
(D)	Seat height front	480 – 510 mm, in increments of 10 mm
(E)	Seat height rear	400 – 480 mm, in increments of 10 mm
(F)	Backrest height	315 – 480 mm, in increments of 15 mm
(G)	Total length	75°: approx. 830 mm 90°: approx. 760 mm
(H)	Seat width	Seat width + 170 mm



## FRAME

The küschall **K-Series**<sup>attract</sup> frame is available in aluminium. Aluminium frames come with frame angles of 75° and 90°.

Frame		Front seat height (SHv) in mm (with a 24" rear wheel)	Lower leg length (UL) with standard-mounted bar*	Seat depth (ST)
Alu	75° standard	480 to 510	SHv -110 to SHv -30	375 to 475
	90° standard	480 to 510	SHv -130 to SHv -40	375 to 475

\*For **lower leg lengths**, the high-mounted footrest must be used.

→ Chapter: Footrests, "Assembling and adjusting high-mounted footrests"





## SEAT

### Seat width (SB)

Available seat widths: SB 360 to 480 in 20 mm steps.

Changing the seat width is very complicated and requires the replacement of numerous parts.

### Seat depth (ST)

Available seat depths: ST 375 to 475 in 25 mm steps.

Changing the seat depth requires the replacement of the seat rails, the seat cover and potentially also the seat cushion.

### Front seat height (SHv)

The front seat height is dependent on several factors that interact with each other. The size of the rear wheels determines the height of the sub-structure. In addition to the positioning of the brackets on the seat module, the frame, seat depth and rear seat height influence the seat height.

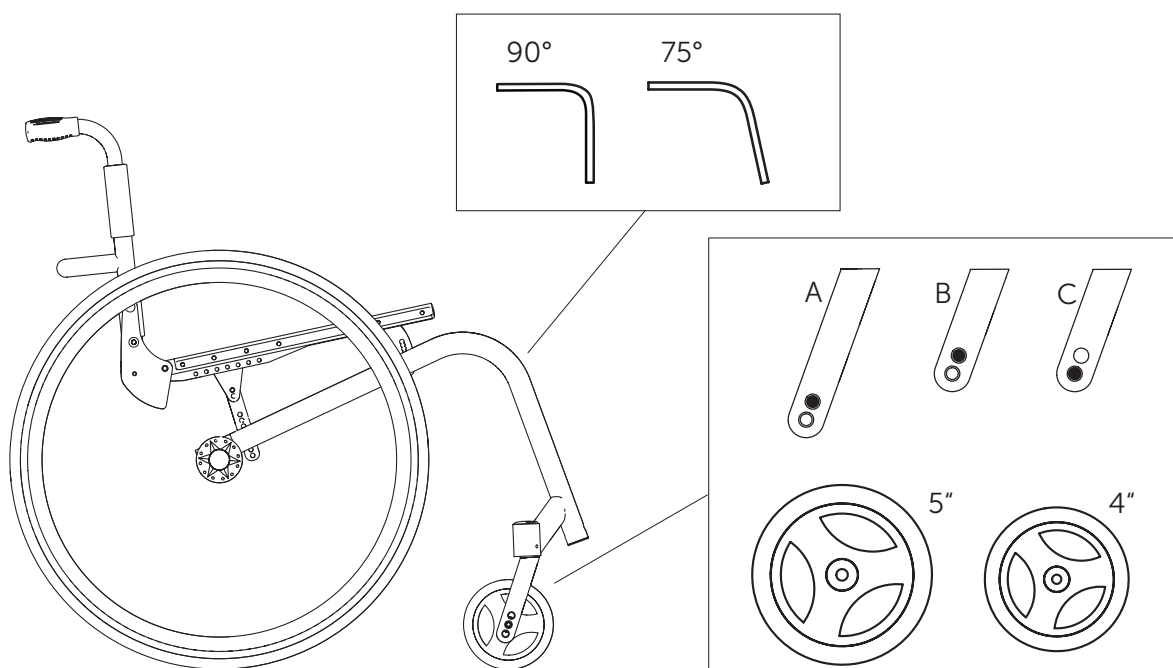

Possible front and rear wheel combinations			
Rear wheel	Frame	●4"	●5"
24"	75°	A	C
	90°	B	-



Only select combinations listed in the Table to ensure that the frame is straight and the front wheel supports are perpendicular to the ground.



If the rear wheel, front wheel and front wheel fork are defined, the front seat height can be adjusted by changing the position of the seat module within the frame. There is 1 bracket available with 8 fixing options.

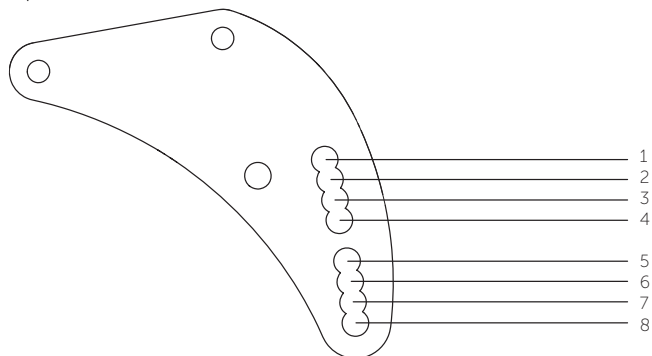

### Positioning or replacing the brackets at the front for setting the front seat height (SHv)

Difficulty: ●●●

Tools: ● 4, 5

- Remove the rear wheels, fold the backrest forward and place the wheelchair on its back.
- Remove all screws on one side that hold the seat cover to remove tension.
- Loosen the screws **A** and **B** that connect the seat brace **C** to the seat module or the frame on both sides.
- Remove the screw **E** and place it in the bracket's **D** other hole.
- Refit the rear wheels, stand the wheelchair back up and check the position of the seat braces **C**. They must be as perpendicular to the ground as possible.
- Reattach the seat cover and tighten the screws.
- Tighten the screw connections **A** and **B** of the seat braces and **E** and **F** of the front brackets again.
- Carry out the same setting on both sides.

**A** → 7 Nm

**B** → 13 Nm

**E** → 7 Nm

**F** → 7 Nm

**i** Note: ensure that adjusting the front seat height results in a change to the seat angle. It may be necessary to correspondingly adjust the rear seat height (SHh) or the backrest angle.

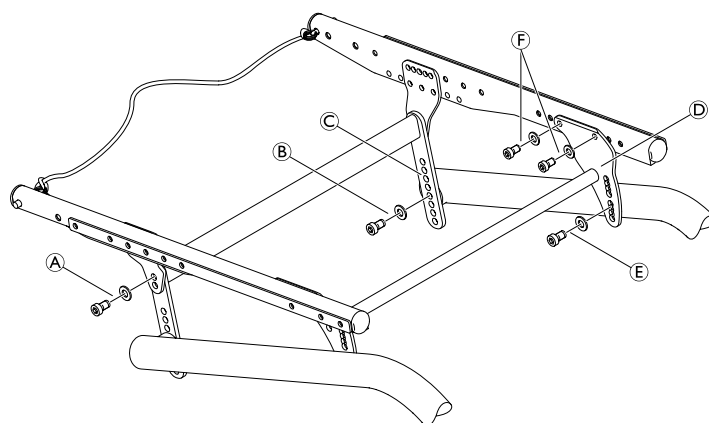



## Rear seat height (SHh)

The seat braces can be repositioned to adjust the rear seat height.

Generally, we recommend fixing the seat braces to the hole A on the frame.

Following table serves as an example, the positions can vary.

Rear seat height based on wheel position	
SHh	Hole combination
400	A 1
410	A 2
420	A 3
430	A 4
440	A 5
450	A 6
460	A 7
470	B 7
480	C 7

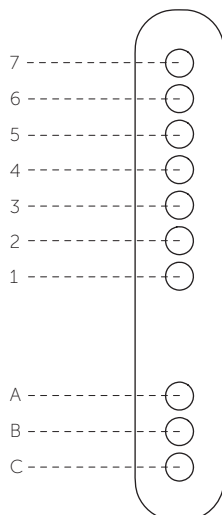

## Adjusting the rear seat height (SHh)

Difficulty: ●●●

Tools: ● 5

- Remove the rear wheels, fold the backrest forward and place the wheelchair on its back.
- Remove all screws on one side that hold the seat cover to remove tension.
- Loosen the screw **A** for the front bracket on both sides.
- Loosen the screw **C** and remove the screws **D** and the connecting bar **E**.
- Carry out the same setting on both sides.
- Slide the seat brace against the rear bracket so that the required holes overlap.
- Insert the connecting bar **E** and fix it with screw **D**.
- Refit the rear wheels, stand the wheelchair back up and check the position of the seat brace **C**. It must be as perpendicular to the ground as possible.
- Reattach the seat cover and tighten the screws.
- Tighten the screws **A**, **C** and **D**.

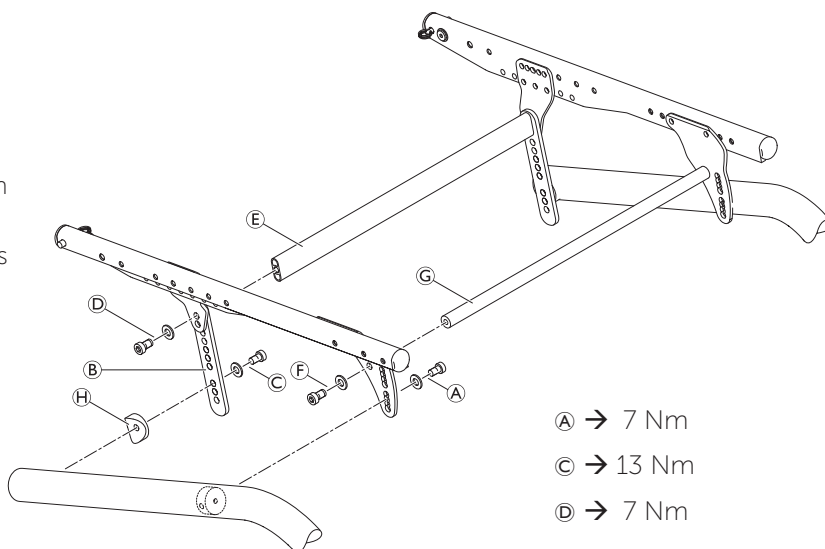

- A** → 7 Nm
- C** → 13 Nm
- D** → 7 Nm

Note: ensure that adjusting the rear seat height results in a change to the seat angle. It may be necessary to correspondingly adjust the front seat height (SHv) or the backrest angle.

## Seat angle (SW)

The seat angle is determined by the difference between the rear seat height (SHh) and the front seat height (SHv).



## Tipping point adjustment

The tipping point of the wheelchair can be adjusted by changing the horizontal position of the seat module.

Difficulty: ●●●

Tools: ● 4, 5

- Remove the rear wheels, fold the backrest forward and place the wheelchair on its back.
- Remove all screws on one side that hold the seat cover to remove tension.
- Loosen the screws (A), (B) and (E) on both sides.
- Remove the screws (C) and (D) and slide the seat module forwards or backwards.
- Reposition all screws (A), (B), (C), (D) and (E) but do not tighten them.
- Reattach the seat cover and tighten the screws.
- Tighten all screws (A), (B), (C), (D) and (E) alternately and uniformly on both sides.

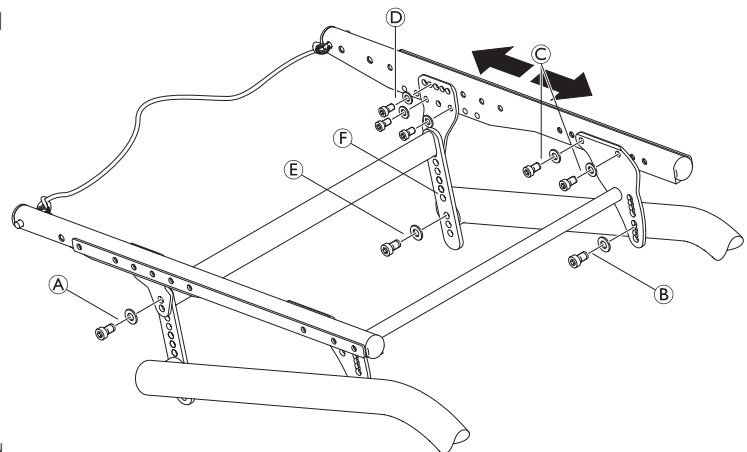

There are 4 possible positions for the rear bracket and 4 possible positions for the front bracket.

Make sure to choose the corresponding position front to back.

 Note: ensure that the seat brace (F) is as vertical as possible following an adjustment.

- (A) → 7 Nm
- (B) → 7 Nm
- (C) → 7 Nm
- (D) → 7 Nm
- (E) → 13 Nm



### BACKREST

The adjustable back is fitted with hook and loop bands and a cover. Apart from the adjustable back there is the light cover, which is produced individually for each backrest height (RH) and seat width (SB).

<i>Backrest height (RH) to cover, backrest tube, pushhandles and bands</i>					
RH	cover	backrest tube ①	standard pushhandles ④ foldable pushhandles ⑤		
			pushhandle ④ telescopic tube straight ⑤	bands above stabilizing bar	top band
315	S	L	S	1-band ⑥	backrestband, 10 cm ⑦
330	S	L	S	1-band ⑥	
345	M	L	S	2-bands ⑧	
360	M	L	S	2-bands ⑧	
375	M	L	S	2-bands ⑧	
390	M	L	L	2-bands+1-band	
405	M	L	L	2-bands+1-band	
420	L	L	L	2-bands+1-band	
435	L	L	L	2-bands+1-band	
450	L	L	L	2 x 2-bands ⑧	
465	L	L	L	2 x 2-bands ⑧	
480	L	L	L	2 x 2-bands ⑧	

\* RH 270 only for standard pushhandles

<i>Backrest height (RH) to pushhandles, telescopic tubes and bands</i>					
RH	without pushhandles ③		height adjustable pushhandles, rearsset ④		
	bands above stabilizing bar	top band	telescopic tube bended ③	bands above stabilizing bar	top band
315	1-band ⑥	endband, 10 cm ⑦	S	1-band ⑥	5 cm ⑧
330	1-band ⑥		S	1-band ⑥	
345	1-band ⑥		S	1-band ⑥	
360	2-bands ⑧		S	1-band ⑥	endband, 10 cm ⑦
375	2-bands ⑧		M	1-band ⑥	
390	2-bands ⑧		M	2 x 1-band ⑥	
405	2-bands+1-band		M	2 x 1-band ⑥	
420	2-bands+1-band		M	2 x 1-band ⑥	
435	2-bands+1-band		L	2-bands+1-band	
450	2-bands+1-band		L	2-bands+1-band	
465	2 x 2-bands ⑧		L	2-bands+1-band	
480	2 x 2-bands ⑧		L	2-bands+1-band	

A 1-band strap ⑥ is placed beneath the stabilizing bar if there is a clothes-guard, and a 2-bands strap ⑧ if there is a mudguard.

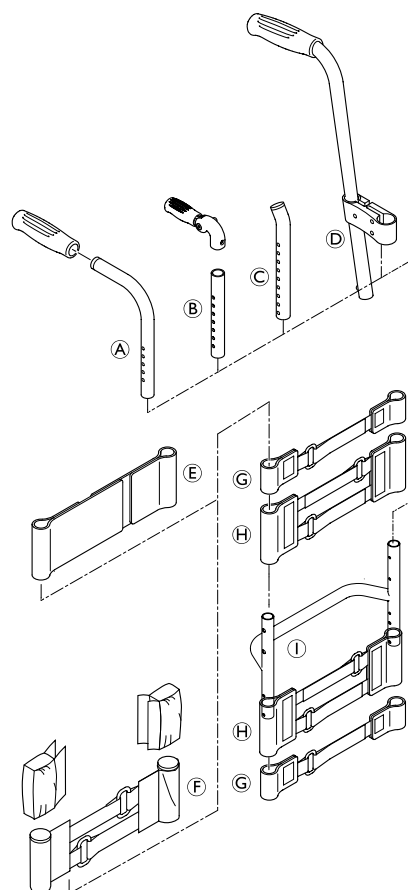



## Backrest height (RH)

The height of the backrest can be adjusted by moving the backrest tube.

### Adjusting the backrest height

#### Readjusting the push handle/telescopic tube

Difficulty: ●○○

Tools: ● 3, ○ 8

- Remove the backrest padding.
- Remove the screw connection ① and adjust the desired height of the push handle or the telescopic tube. Insert the screw connection ① again and tighten the nut.
- Carry out the same setting on both sides.
- Refit the backrest padding.

 If the desired height cannot be achieved, you must use a different telescopic tube or push handle.

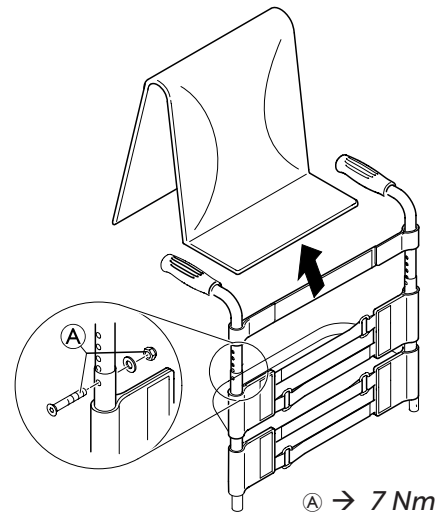

### Securing/adjusting the release cord

Difficulty: ●○○



#### WARNING!

Risk of injury to the user during use as a result of the backrest folding over unintentionally.

If the release cord is too taut, the locking mechanism ② can open unintentionally.

→ Make sure that the release cord is not too taut.

- Knot the release cord ①, left and right, to the wire rings ③ such that it is free from tension, but still ensuring that there is only minimal slack (< 5 mm).

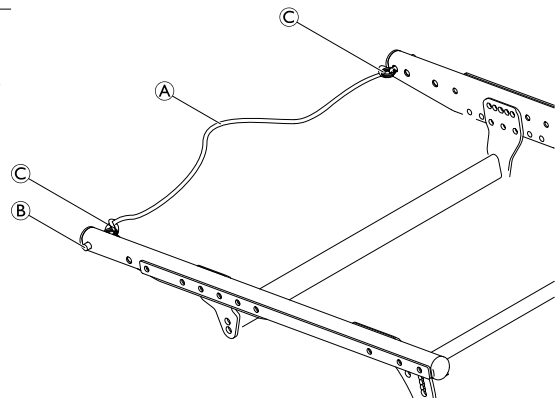



### Replacing the backrest tube

Difficulty: ●○○

Tools: ● 3, 4 ○ 8, 10

- 1** Remove the backrest padding.
  - Slide the backrest bands upwards or downwards to gain access to the screws **A**. Remove the screws and nuts on both sides.
  - Remove the push handles or the telescopic tubes and remove the upper hook and loop bands.
  - Remove the screws **B** on the backrest joint.
- 2** Remove the lower hook and loop bands and the sleeve **D** with the adjustment screw **E** from the backrest tube **C** and fit both to the new backrest tube.
  - Fit the backrest tube to the backrest joint with the screws **B**. Here, first fit the lower screw followed by the upper screw.
  - Fit the upper hook and loop bands and the push handles or the telescopic tubes again and fix them with screws **A** and nuts.
  - Carry out the same setting on both sides.
  - Refit the backrest padding.

**!** The excentre plates must be adjusted identically on both sides of the wheelchair, → Adjusting the backrest angle.

#### Check:

Check the settings of the adjustment screws **E** on both sides. The screw head must only lightly touch the seat module when the backrest is in the upright position. If necessary, readjust the length by releasing the counter nut and tightening or loosening the adjustment screw. Then retighten the counter nut **F**.

**!** Incorrectly adjusted adjustment screws result in damage to the backrest joint's mechanism, → Adjusting the backrest joint.

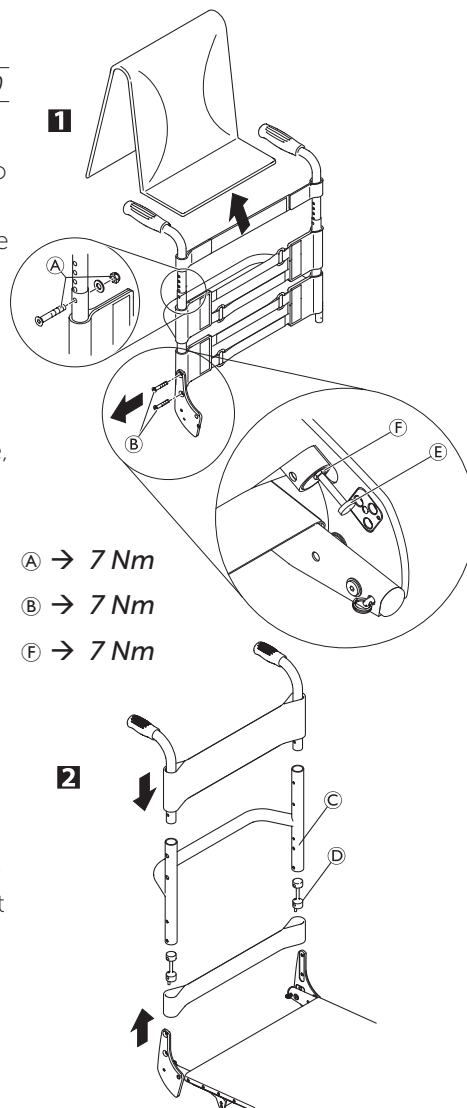



## Replacing the handle

An adhesive (e.g. hair spray) is used in these instructions. When applied to the handle, this substance works as a lubricant and as an adhesive once dry.



After drying, the adhesive used must be able to resist a pull-off force of 750 N. If in doubt, contact Invacare.

Difficulty: ●●○

- Remove the old handle.
- Remove any residue (residual adhesive, grease, dust) from the push handle tube.
- Apply a thin layer of hair spray all over the surface of the push handle tube onto which the handle is to be slid.
- Apply a thin layer of hair spray to the inside of the handle.
- Slide the new handle onto the push handle tube.
- Move the handle into the correct position (grooves facing upwards).



If a long handle has been fitted and this is to be replaced with a short one, the push handle tube must be shortened by 35 mm. The push handle tube must be replaced when switching from a short to a long handle.

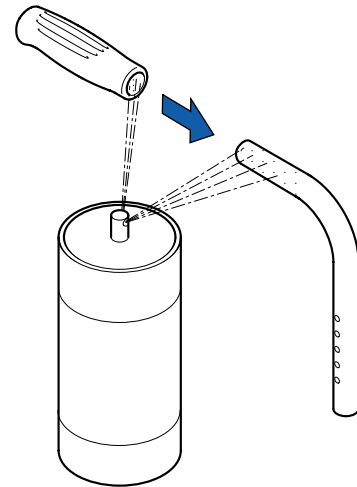

## Replacing foldable push handles

Difficulty: ●○○

Tools: Hole punch pliers 6 mm, ● 3, 4

- Remove the old foldable push handle.
- Pull down the backrest cover (F) on the telescopic tube, until its hole (B) is uncovered.
- ! **IMPORTANT!**  
Make sure that the threaded insert (E) (part no. 1580450) supplied with the new push handle is used for assembly.
- Place the threaded insert (E) in the telescopic tube.
- Punch a hole through the backrest cover with a distance of 10 mm from the upper edge, using hole punch pliers (see graphic below).
- Slide the new foldable push handle (A) onto the telescopic tube.
- Pull up the backrest cover, until it covers completely the rear hole in the push handle.
- Fix the foldable push handle with screw (C) and washer (G).
- Check screws (D) on both sides of the push handle and re-tighten if necessary.
- Carry out the same steps for the other push handle.



Make sure that the folding force is approximately 5 N (0.5 kg).



Fixing screw (C) may only be used once. Alternatively the screw can be cleaned (remove old thread locking adhesive) and reinstalled with new low-strength thread locking adhesive.



The retrofit of foldable push handles requires new tubing.

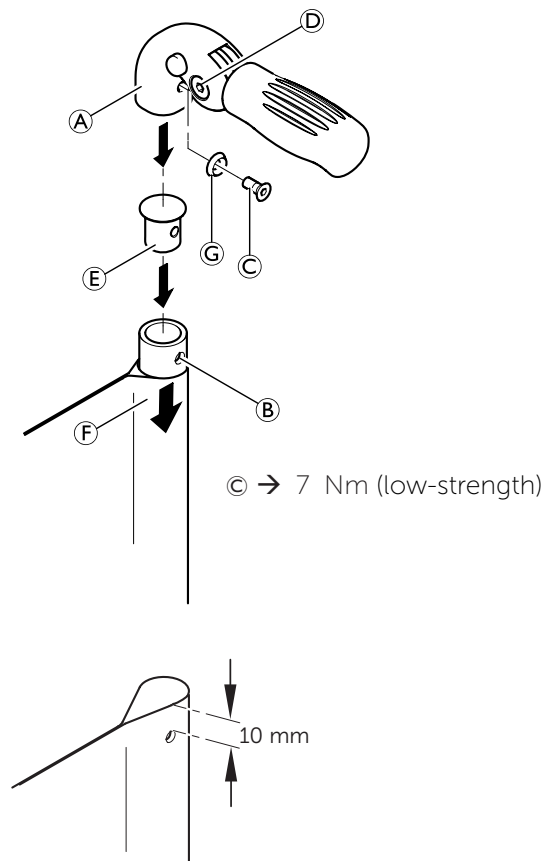





### Backrest angle (RW)

The angle of the backrest can be changed by repositioning the excentre plate in the backrest joint plate.

The following angles (measured from the seat) can be set:

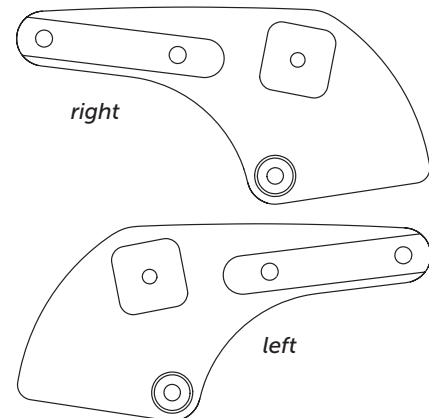
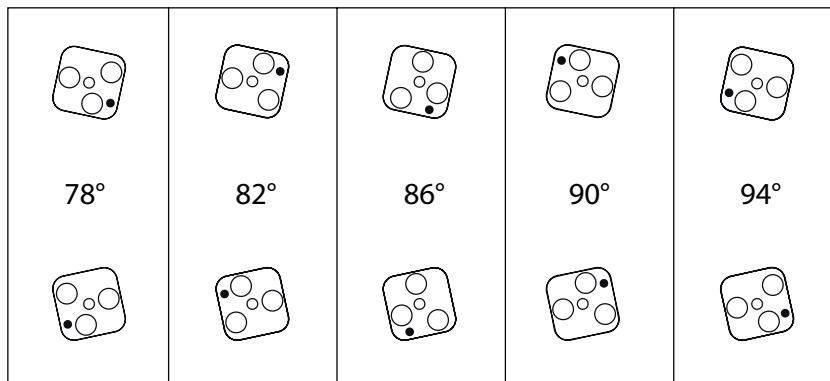

### Adjusting the backrest angle

Difficulty: ●●○

Tools: ● 3, — C 10

- 1 Fold down the backrest and release the counter nut of the adjustment screw (A) and screw it in completely.
- 2 Remove the screw (B) on the excentre plate (C). Remove the excentre plate and reinsert it in the desired position.

The excentre plates must be set identically on both sides of the wheelchair.

- Reinsert the screw (B) and tighten it.
- Fold the backrest up until the stop bolts (D) engage and unscrew the adjustment screw (A) until it touches the frame and the backrest joint no longer moves.
- Tighten the counter nut (E).

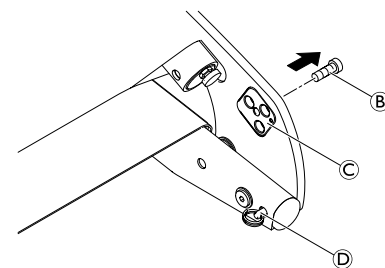
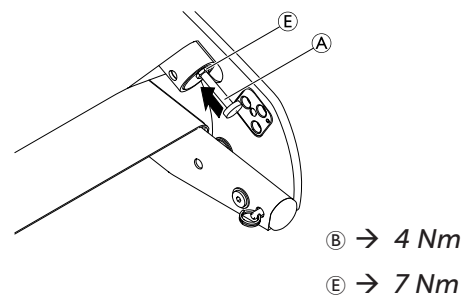

### Adjusting the backrest joint

Difficulty: ●●○

Tools: — C 10

- Put the backrest up and let the pin (A) engage.
- Press the backrest forwards to ensure the joint cannot move.
- Unscrew the screw (C) until it touches the spigot (D) of the seat frame.
- Screw the screw back in by between a 1/4 and a 1/2 turn and counter with the counter nut (E).
- Correctly adjust the backrest joint on both sides.

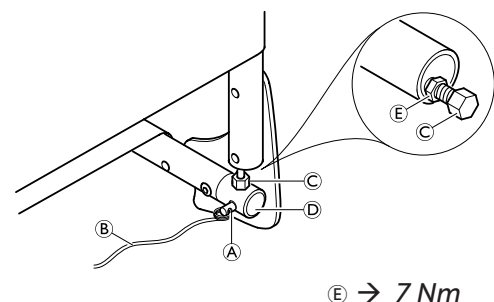

### Function check:

Sit in the wheelchair and lean back so that the backrest is strained. Upon pulling the release cord (B), the pin (A) must be easily removed on both sides and must fully glide back in upon letting go of the release cord.



## FOOTRESTS

The footrest must be selected in accordance with the seat width. A standard footrest and an angle-adjustable footrest are available.

### Lower leg length (UL)

To change the lower leg length, the footrest can be fixed at a higher or lower position. → Table, Chap. Frame. The shortest lower leg lengths can be achieved using the high-mounted footrest. → <Fitting and adjusting high-mounted footrest>

### Replacing footrests

Difficulty: ●○○

Tools: ● 4, ⬡ 8

- Remove the screw connections (A) on both sides.
- Remove the footrest and replace it with a new one.
- Tighten the screw connections (A) on both sides.
- Carry out the same setting on both sides.

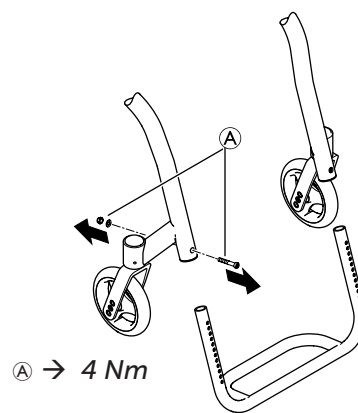

### Adjusting the footrest height

Difficulty: ●○○

Tools: ● 4, ⬡ 8

The height of the footrest can be adjusted in 10 mm steps.

- Remove the screw connections (A) on both sides.
- Slide the footplate to the desired height.
- Tighten the screw connections (A) on both sides.
- Carry out the same setting on both sides.

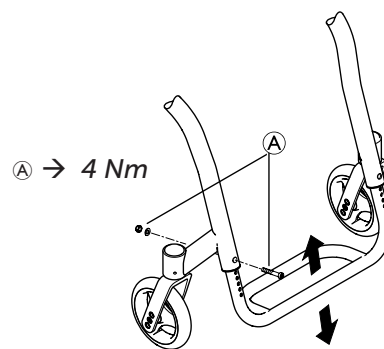

### Assembling the foot plate cover

Difficulty: ●●○

Tools: ● 3, drill, drill bit: Ø 7 mm

- Position and affix the footplate support (C) cleanly to the footplate (B).
- Thread the footplate through the holes on the footplate support.
- Removing the foot plate support
- Drill through foot plate (7 mm).
- Blind rivets (Tubtara) should be used in accordance with supplier instructions.
- Fasten the footplate support (A) with screws.

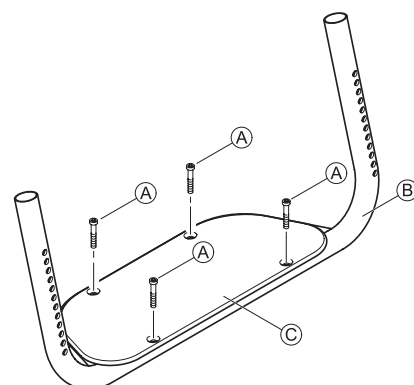

### Replacing the footplate support

Difficulty: ●○○

Tools: ● 3

- Remove screws (A) and footplate support (C).
- Fasten the new foot plate support (A) with bolts.



### Angle-adjustable footplate, adjusting the angle

Difficulty: ●○○

Tools: ● 4, ◻ 10

- To adjust the angle, release the four screw connections (A) until the footplate can be moved.
- 1 Check and/or adjust the distance between the left and the right sides by pushing in or pulling out the tubes below the footplate in such a way that the bearings blocks are perpendicular to the ground.
- 2 Tilt the footplate into the desired position and tighten the screw connections (A).



The angle of the footplate must be set so that the user's feet cannot slide off the plate.



Make sure that the footplate has a minimum distance of 20 mm to the floor at its lowest point.

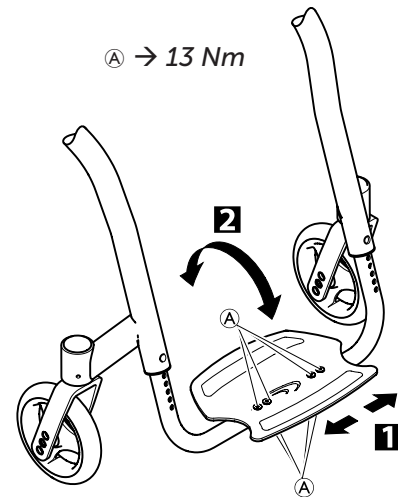

### Fitting and adjusting high-mounted footrest

Difficulty: ●○○

Tools: ● 4, 5 ◻ 8, 10

- Fit the frame bar (D) for the high-mounted footrest to the front frame on both sides using the screw connections (A).
- Fix the clamp set (C) to both sides of the frame using the screw connection (B). Only tighten lightly.
- Slide the high-mounted footplate (E) into the clamp set and to the desired height.
- Tighten the screw connections (B) on both sides.

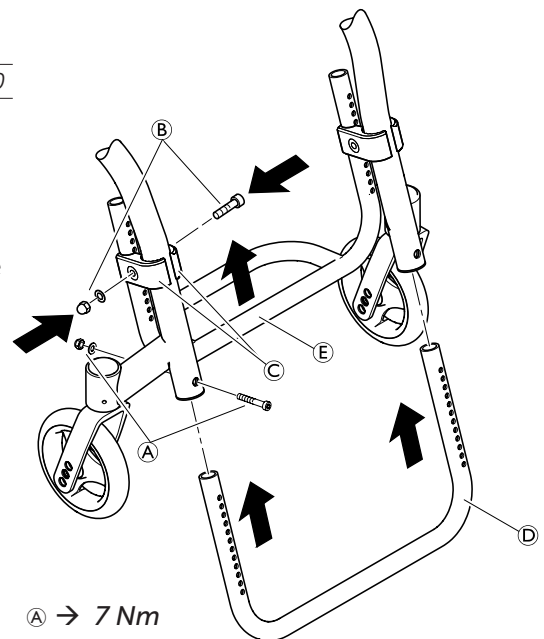



## SIDE PARTS

### Fitting and adjusting a height-adjustable armrest

Difficulty: ●●○

Tools: ● 4, 5, ✕ 2

- 1** Fit the holder **A** and the bracket **B** to the seat module on both sides. Tighten the screws **C** only lightly.
- Fit the bar **D** between the brackets **B** using screws **E**. Tighten the screws **C**.
- 2** To adjust the armrest height, insert the armrest **F** into the holder **A**.
- Loosen the screws **G** for the height adjustment and slide it into the desired position.
- Then retighten the screws **G** for the height adjustment.
- By tightening or loosening the screws **H**, you can adjust how easily the armrest can be pulled out or pushed in.

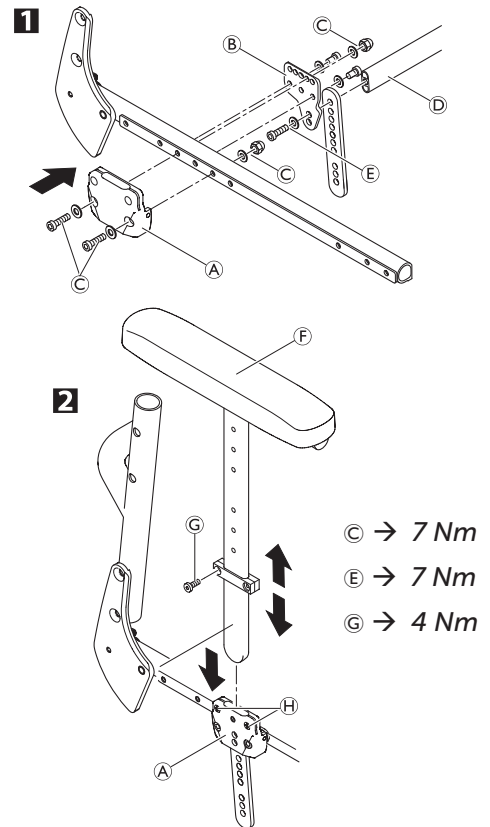



### Clothes-guard/mudguard

The clothes-guard fitted as standard can be replaced by a mudguard. Clothes-guard and mudguard are available in plastic or in carbon. For the carbon mudguard there is an additional size (XL) for the two smallest rear seat heights (SHh).

Clothes-guard size		
	Wheel size	
SHh	24"	
400	L	
410	L	
420	L	
430	L	
440	M	
450	M	
460	M	
470	M	
480	M	

Mudguard size plastic		
	Wheel size	
SHh	24"	
400	L	
410	M	
420	M	
430	M	
440	M	
450	M	
460	M	
470	M	
480	M	

Mudguard size carbon		
	Wheel size	
SHh	24"	
400	L	
410	L	
420	L	
430	L	
440	M	
450	M	
460	M	
470	M	
480	M	



### Replacing the clothes-guard

Mounting element **A** must be mounted with parts **F**, **E**, **D** on the backrest tube **G**.

Difficulty: ●●○

Tools: ● 3, 4

- 1** If present, remove the clothes-guard to be replaced by loosening the screw connection **C**.
- Check the correct position of the clothes-guard **B** with fitted rear wheel. Here, find the suitable height on the clothes-guard for fixing the screw connection **C** to the backrest mounting element **A**.
- Gently tighten screw connection **C** until it slightly jams.
- Secure with grub screw **H**.
- 2** If necessary, the holder **I** on the seat module can be replaced by removing/fixing screw **J** with washer and cap nut **K**.

**i** The clothes-guard is correctly positioned if it can be inserted between the seat module and the holder and the upper edge runs above the rear wheel.

**K** → 7 Nm

**H** → 4 Nm

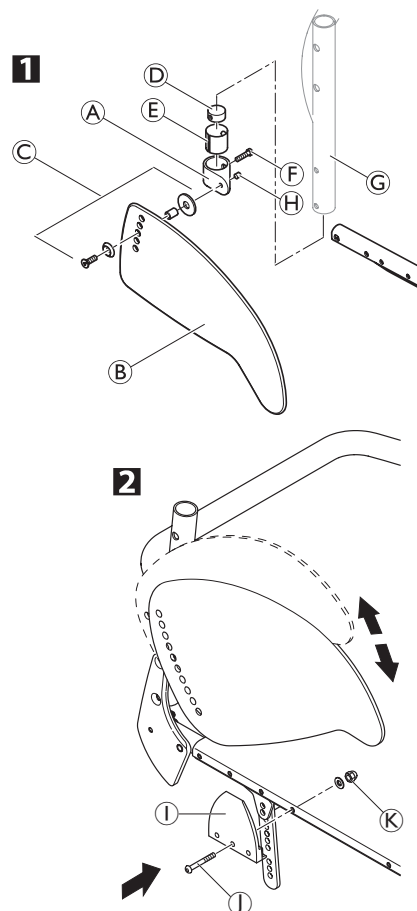

### Fitting the mudguard

Difficulty: ●●○

Tools: ● 3, 4,  $\square$  10 x 2

Remove the clothes-guard and the mounting elements on the backrest and the seat.

- 1** Fit the holder to the seat module using the screw connections **A** and then refit the rear wheel.
- 2** Slightly loosen the screws **B** on the adjustment plate and slide it along the mudguard carrier until the mudguard is at the right height.
- The position of the mudguard can also be adjusted: Here, loosen the screw connections **C** and **D**, position the mudguard as required and tighten the screw connections **C** and **D** again.
- Tighten the screws **B** again.
- Carry out the same setting on both sides.
- By tightening or loosening the screws **E** you can adjust how easily the armrest can be pulled out or pushed in.

**i** The existing axle may not be sufficiently long for the new configuration with mudguard. In this case, a longer axle must be fitted. → Changing the wheel camber / fitting and adjusting an axle

**!** The distance between the mudguard and the wheel must be either < 8 mm or > 25 mm to prevent fingers from becoming caught between the wheel and the mudguard.

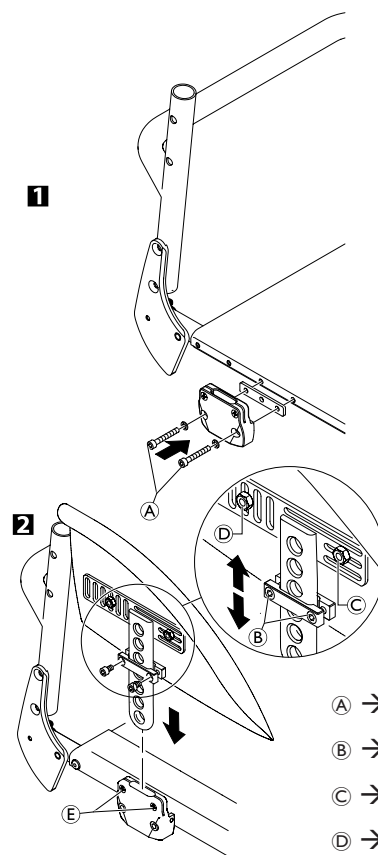

**A** → 7 Nm

**B** → 4 Nm

**C** → 7 Nm

**D** → 7 Nm



### FRONT WHEELS

#### Replacing a front wheel

Difficulty: ●○○

Tools: ● 2x3

- 1 Remove screws A.
- 2 Remove the wheel axle B.
- 3 Remove the front wheel C.

 The bearings are pre-mounted in the front wheel.

- 3 Slide the axle B through the fork D and the bearings of front wheel C and fix the axle using screws A. Here, use the new screw supplied with the wheel as this screw comes with a thread-locking device.

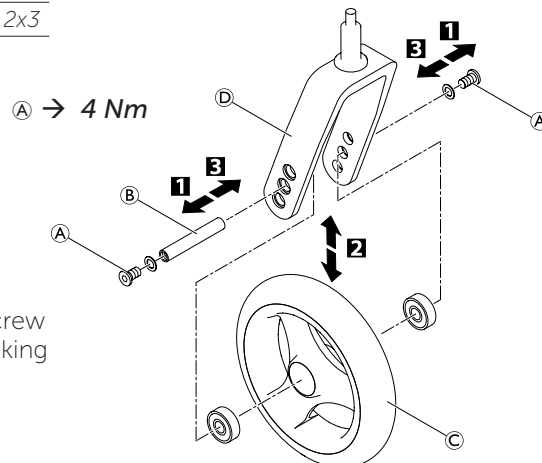

#### Function check:

The wheel may not wobble, but must rotate easily.

#### Replacing a front wheel fork

Difficulty: ●●○

Tools: ☞ 10

- Remove the sealing cap A of the bearings block by inserting two screwdrivers into the grooves and flipping it off.
- Remove the nut B with the washer E.
- Remove the front wheel fork C.
- Check the ball bearings D and replace them if necessary.
- Insert the new front wheel fork with the washer E and the nut B and tighten the nut.
- Carry out the function check (see below).
- Replace the sealing cap A.

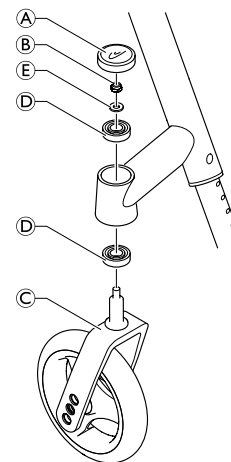

#### Function check:

Tip the wheelchair backwards by 90° so that it is lying on the backrest and the rear wheels. Make sure that the clevis pin is as horizontal as possible. Turn the fork upwards (position A) and let it tip downwards.

The fork has been correctly adjusted if it easily turns to slightly beyond the bottommost point (position B) and then maximally turns back to the bottommost point (position C).

If the fork turns back over the bottommost point or even swings back and forth, it has not been sufficiently tightened. There is a risk that the front wheels will start to wobble at high speeds.

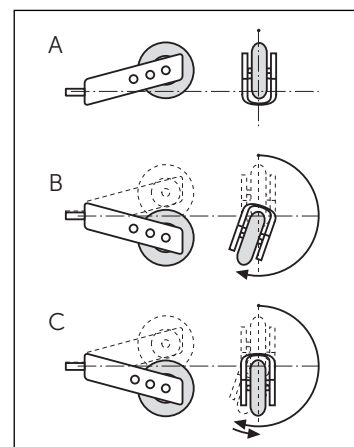



### REAR WHEELS

#### Ensuring the rear wheels are parallel

Difficulty: ●●○

Tools: ● 5

- Loosen the screws **A** on both clamp sets. Rotate the axle tube to set the correct position.
- Tighten the screw **A** on both sides.



This setting must be carried out on a horizontal surface. The track of the rear wheels is correct if the distance between the rear wheels is the same at the front and the back ( $x=y$ ) – measured at the height of the centre of the axle.

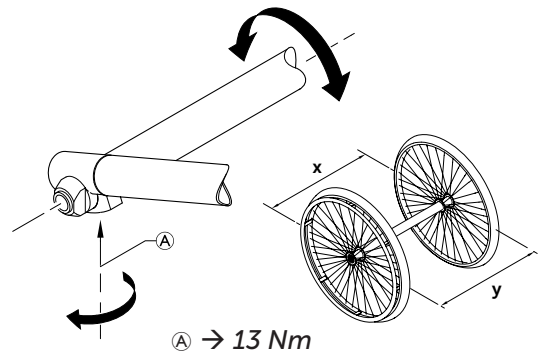

#### Adjusting the removable axle

Difficulty: ●●○

Tools: —C 11, 19

- Remove the rear wheel.
- Hold the end of the removable axle **B** using the straddle spanner.
- Adjust the length  $L$  of the removable axle by turning the nut **A**. The length is correctly adjusted if the removable axle engages correctly when fixing the wheel and wheel has just minimal clearance.



The wheels must be exchanged (left to right side and vice versa) after adjusting both removable axles. The adjustment must now be checked or carried out again to ensure the wheels can be switched.

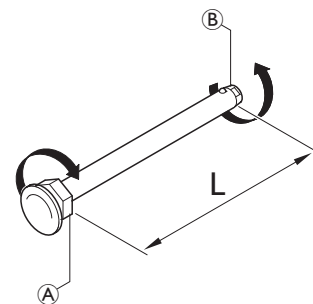

#### Changing the wheel camber

##### Standard axle

Difficulty: ●●○

Tools: ● 5

A new axle must be used to change the wheel camber.

- 1 Remove the screws **A** on both sides and remove the lower part of the axle holder **B**.
  - 2 Replace the axle **C** with a new axle with the desired wheel camber.
  - 3 Attach the lower part of the axle holder **B** on both sides and insert the screw **A**.
- Ensure the rear wheels are parallel,  
→ Ensuring the rear wheels are parallel.
  - Tighten the screws **A** on both sides.

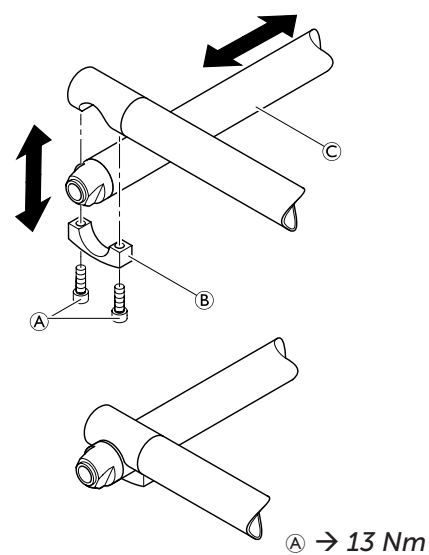





### Repairing or changing an inner tube

Difficulty: ●○○

Tool: tire lever

- Remove the rear wheel and release any air from the inner tube.
- Lift one tire wall away from the rim using a bicycle tire lever. Do not use sharp objects such as a screwdriver which could damage the inner tube.
- Pull the inner tube out of the tire
- Repair the inner tube using a bicycle repair kit or, if necessary, replace the tube.
- Inflate the tube slightly until it becomes round.
- Insert the valve into the valve hole on the rim and place the tube inside the tire (the tube must lie right round the tire with no creases).
- Starting close to the valve, push the tire wall over the edge of the rim using both hands. When doing this, check all the way round to ensure that the inner tube is not trapped between the tire and the rim.
- Inflate the tube to its maximum operating pressure, → Table, chap. Rear wheels, Checking the tire pressure. Check that no air is escaping from the tire.

### Repairing or changing a solid tire

Solid tires must be fitted by a qualified technician.



## BRAKES

### Parking brakes

#### Mounting the parking brake

Difficulty: ●●○

Tools: ● 5

- Position the brake holder (B) around the front frame tube (C).
- Place the brake (D) in the brake holder.
- Screw the bolt (A) with washer into the brake assembly but do not tighten.
- Rotate the brake holder assembly around the frame tube to adjust the lateral distance of the brake.
- Rotate the brake in the brake holder to achieve a horizontal position of the brake rod (E) to the tire.
- Fully apply the brake and slide it towards the tire until the brake rod bears flush against the tire.
- Release the brake and slide it 3 mm backwards and tighten the bolt.

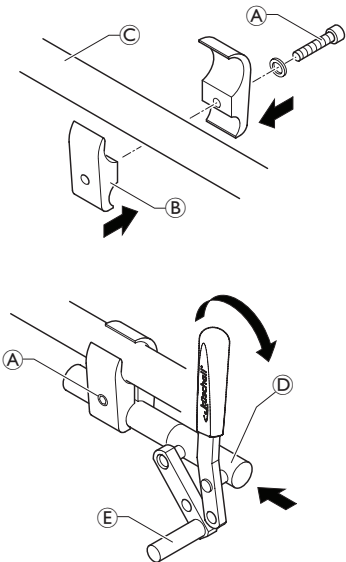

Ⓐ → 13 Nm / 10 Nm with carbon frame

#### Adjusting the parking brake

Difficulty: ●○○

Tools: ● 5



#### WARNING!

The parking brakes must be readjusted whenever the rear wheels are replaced or the wheel camber is changed.

The parking brake function is only guaranteed if the tire has the corresponding air pressure.

- Check the tire pressure in the rear wheels and correct if necessary.
- Slightly loosen bolt (A) of the brake holder.
- Change the position of the brake assembly as described above.
- Tighten the bolt.



#### IMPORTANT!

The force to apply the brake must be 60 N (maximum).



Very little force is required for activating and deactivating the brake. If necessary, a brake lever extension can be mounted.

#### Visual check

Check that the parking brakes are positioned correctly. The brake is set correctly if the brake rod depresses the tire by no more than 4 mm when the brake is applied. (In the case of push/pull and standard brakes this will be the case when the brake shoe is approx. 25 mm away from the tire when released.)

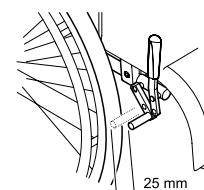

#### Function check

Place a weighted wheelchair with parking brake engaged facing uphill and then facing downhill on a ramp with an incline of 7°. The wheelchair must not move.



## OPTIONS & ACCESSORIES

### Antitipper

There are two different sizes of antitipper for both the left and the right sides.

#### Fit antitipper without rear wheel extension

Difficulty: ●●○

Tools: ● 3, 5, 8

- 1** Loosen the screws **A** and remove the lower part of the axle holder **B**.
- 2** Fix the adaptation holder clip **C** with screws **A**.
- Check that the rear wheels are parallel,  
→ Chap. Rear wheels; Ensuring the rear wheels are parallel.
- 3** Fix the antitipper to the adaptation holder **C** using screws **D**. Measure the distance between the antitipper and the ground,  
→ Adjusting the height of the antitipper.

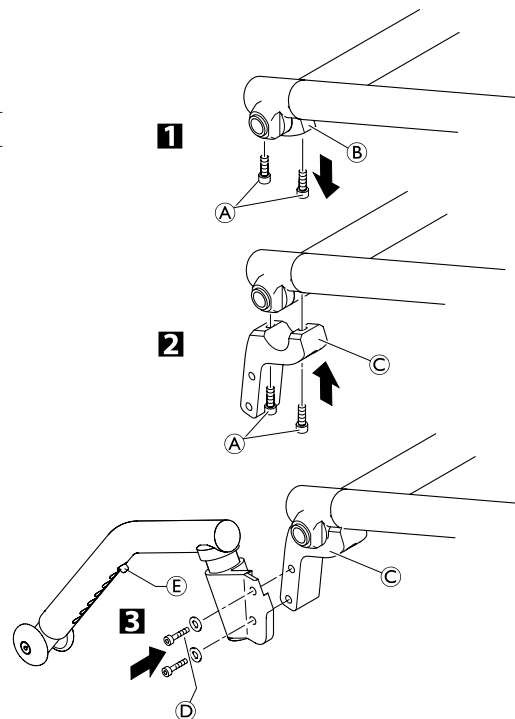

#### Adjusting the length of the antitipper

Difficulty: ○○○

Tools: ● 3, 5, 8

- Press the adjustment button **E** on the antitipper and pull the antitip tube into the desired position. Let the adjustment button latch into the adjacent hole.

#### Function check:

The distance between the antitipper and the ground must be 50 - 70 mm. It must be easy to fold up the antitipper.

Tip the wheelchair backwards using the antitipper until the axle is perpendicular to the antitipper's point of contact with the ground. In this position, the distance between the rear wheel and the ground must be at least 50 mm.

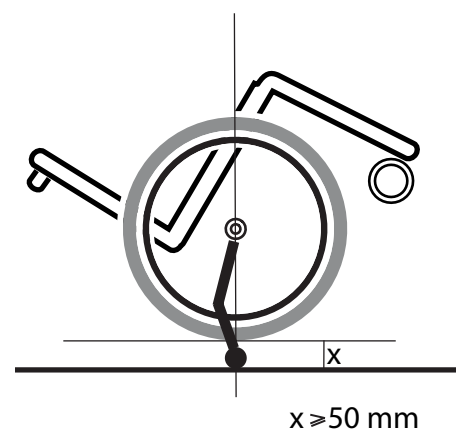



## Tipper aid

### Fitting the tipper aid

Difficulty: ●○○

Tool: ● 5

- 1 Loosen the screws (A) and remove the lower part of the axle holder (B).
  - 2 Fix the adaptation holder clip (C) with screws (A).
- Check that the rear wheels are parallel,  
→ Chap. Rear wheels; Ensuring the rear wheels are parallel.
  - Secure adaptation support (D) with bolt (E) onto adaptation holder clip (C).
  - Push in spring clip (F) and push the tipper aid into the adaptation support.
  - Make sure that the spring clip is correctly engaged in the adaptation support.

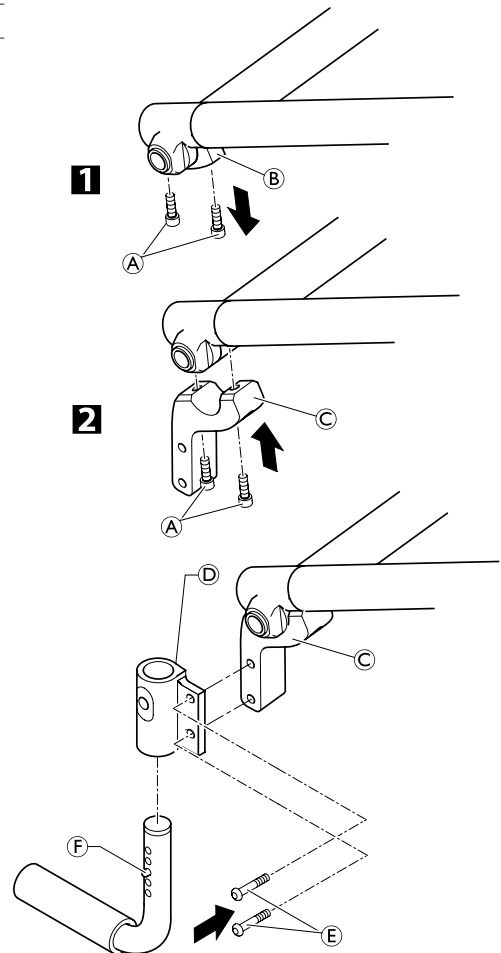

### Height adjustment

Difficulty: ●○○

- To adjust the height, remove cap (G) and, e.g. using a screwdriver, compress the spring (F) inside the tube and push into the required position.

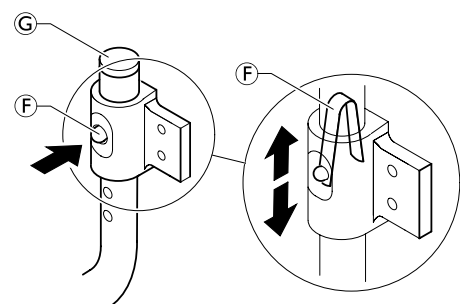



## Mounting the posture belt

Difficulty: ●○○

Tools: 10 mm

1. Remove cap nut (A) and washer (C).
2. Attach the steel strap (D) to the backrest joint screw (B) using the supplied, new cap nut (A) and washer (C).



Ensure that the webbing of the posture belt is not twisted during assembly and the locking mechanism shows towards the front.

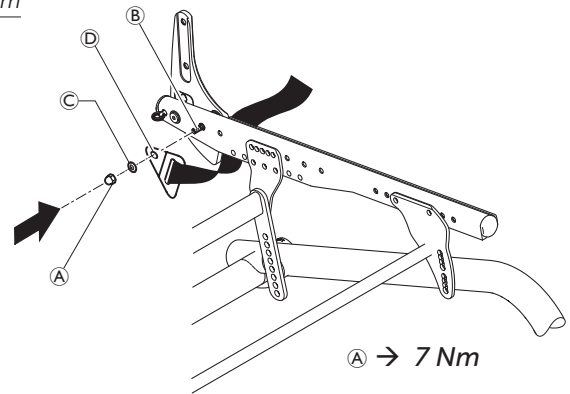

## Attaching the snap hook symbols

Front side

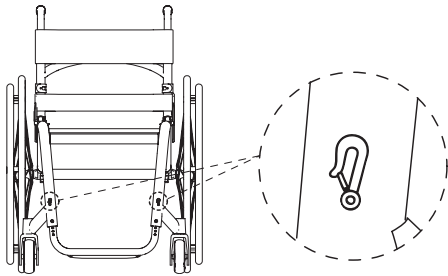

Rear side

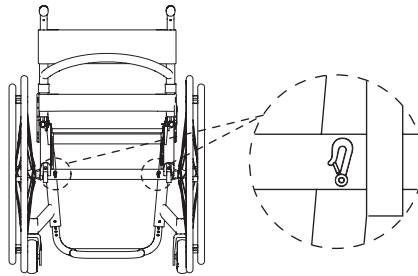



Invacare France Operations  
Route de St Roch  
F-37230 Fondettes  
France

Service manual  
KÜSCHALL K-SERIES attract  
ENGLISH | 2018-07

**Invacare distributors:**

**Belgium & Luxemburg:** Invacare nv • Autobaan 22 • B-8210 Loppem

Tel: (32) (0)50 83 10 10 • Fax: (32) (0)50 83 10 11 • [belgium@invacare.com](mailto:belgium@invacare.com) • [www.invacare.be](http://www.invacare.be)

**Danmark:** Invacare A/S • Sdr. Ringvej 37 • DK-2605 Brøndby

Tel: (45) (0)36 90 00 00 • Fax: (45) (0)36 90 00 01 • [denmark@invacare.com](mailto:denmark@invacare.com) • [www.invacare.dk](http://www.invacare.dk)

**Deutschland:** Invacare GmbH • Alemannenstraße 10 • D-88316 Isny

Tel: (49) (0)75 62 7 00 0 • Fax: (49) (0)75 62 7 00 66 • [kontakt@invacare.com](mailto:kontakt@invacare.com) • [www.invacare.de](http://www.invacare.de)

**Eastern Europe, Middle East & CIS:** Invacare EU Export • Kleiststraße 49 • D-32457 Porta Westfalica

Tel: (49) (0)57 31 754 540 • Fax: (49) (0)57 31 754 541 • [webinfo-eu-export@invacare.com](mailto:webinfo-eu-export@invacare.com) • [www.invacare-eu-export.com](http://www.invacare-eu-export.com)

**España:** Invacare SA • c/Areny s/n • Polígon Industrial de Celrà • E-17460 Celrà (Girona)

Tel: (34) (0)972 49 32 00 • Fax: (34) (0)972 49 32 20 • [contactsp@invacare.com](mailto:contactsp@invacare.com) • [www.invacare.es](http://www.invacare.es)

**France:** Invacare Poirier SAS • Route de St Roch • F-37230 Fondettes

Tel: (33) (0)2 47 62 64 66 • Fax: (33) (0)2 47 42 12 24 • [contactfr@invacare.com](mailto:contactfr@invacare.com) • [www.invacare.fr](http://www.invacare.fr)

**Ireland:** Invacare Ireland Ltd • Unit 5 Seatown Business Campus • Seatown Road • Swords • County Dublin – Ireland

Tel : (353) 1 810 7084 • Fax: (353) 1 810 7085 • [ireland@invacare.com](mailto:ireland@invacare.com) • [www.invacare.ie](http://www.invacare.ie)

**Italia:** Invacare Mecc San s.r.l. • Via dei Pini 62 • I-36016 Thiene (VI)

Tel: (39) 0445 38 00 59 • Fax: (39) 0445 38 00 34 • [italia@invacare.com](mailto:italia@invacare.com) • [www.invacare.it](http://www.invacare.it)

**Nederland:** Invacare BV • Galvanistraat 14-3 • NL-6716 AE Ede

Tel: (31) (0)318 695 757 • Fax: (31) (0)318 695 758 • [nederland@invacare.com](mailto:nederland@invacare.com) • [www.invacare.nl](http://www.invacare.nl)

**Norge:** Invacare AS • Grensesvingen 9 • Postboks 6230 • Etterstad • N-0603 Oslo

Tel: (47) (0)22 57 95 00 • Fax: (47) (0)22 57 95 01 • [norway@invacare.com](mailto:norway@invacare.com) • [island@invacare.com](mailto:island@invacare.com) • [www.invacare.no](http://www.invacare.no)

**Österreich:** Invacare Austria GmbH • Herzog Odilostrasse 101 • A-5310 Mondsee

Tel.: (43) 6232 5535 0 • Fax.: (43) 6232 5535 4 • [info@invacare-austria.com](mailto:info@invacare-austria.com) • [www.invacare.at](http://www.invacare.at)

**Portugal:** Invacare Lda • Rua Estrada Velha • 949 • P-4465-784 Leça do Balio

Tel: (351) (0)225 1059 46/47 • Fax: (351) (0)225 1057 39 • [portugal@invacare.com](mailto:portugal@invacare.com) • [www.invacare.pt](http://www.invacare.pt)

**Sverige:** Invacare AB • Fagerstagatan 9 • S-163 91 Spånga

Tel: (46) (0)8 761 70 90 • Fax: (46) (0)8 761 81 08 • [sweden@invacare.com](mailto:sweden@invacare.com) • [finland@invacare.com](mailto:finland@invacare.com) • [www.invacare.se](http://www.invacare.se)

**Suomi:** Camp Mobility • Patamäenkatu 5 • 33900 Tampere

Tel: 09-35076310 • [info@campmobility.fi](mailto:info@campmobility.fi) • [www.campmobility.fi](http://www.campmobility.fi)

**Schweiz/Suisse/Svizzera:** Invacare AG • Benkenstrasse 260 • CH-4108 Witterswil

Tel.: (41) (0)61 487 70 80 • Fax.: (41) (0)61 487 70 81 • [switzerland@invacare.com](mailto:switzerland@invacare.com) • [www.invacare.ch](http://www.invacare.ch)

**United Kingdom:** Invacare Limited • Pencoed Technology Park,

Pencoed, Bridgend CF35 5AQ • Switchboard Tel: (44) (0)1656 776 200, Fax: (44) (0)1656 776 201 •

Customer services Tel: (44) (0) 1656 776 222 • Fax: (44) (0) 1656 776 220 • [UK@invacare.com](mailto:UK@invacare.com) • [www.invacare.co.uk](http://www.invacare.co.uk)

**Australia:** Invacare Australia Pty Ltd • ABN 45 074 676 378, PO Box 5002, 1 Lenton Place, North Rocks, NSW 2151, Australia •

Freephone: 1800 069 042, Fax: 02 8839 5353 • E-mail: [sales@invacare.com.au](mailto:sales@invacare.com.au) • Web: [www.invacare.com.au](http://www.invacare.com.au)

**New Zealand:** Invacare New Zealand • PO Box 62-124, 4 Westfield Place, Mt. Wellington, Auckland, New Zealand •

Freephone: 8000 468 222, Freefax: 0800 807 788 • E-mail: [sales@invacare.co.nz](mailto:sales@invacare.co.nz) • Web: [www.invacare.co.nz](http://www.invacare.co.nz)