

Invacare® SoftCloud™ family

en Alternating mattress system Service Manual



PROVIDER: **Keep** this manual.
The procedures in this manual **MUST** be performed by a qualified technician.

Contents

1 General	3
1.1 Introduction	3
1.2 Symbols in This Manual	3
1.3 Preliminary System Check	3
2 Safety	4
2.1 General Safety Information	4
2.2 Personal Safety Information	4
2.3 Electrical Safety Check	4
3 Digital Control Unit	5
3.1 Components' Overview	5
3.2 Circuit Board (PCB) Overview	5
3.2.1 Ace/Pro PCB	5
3.2.2 Top/Air PCB	5
4 Service Digital Control Unit	6
4.1 SoftCloud Ace/Pro	6
4.1.1 Replacing the Air Filter	6
4.1.2 Replacing the Top Housing	7
4.1.3 Replacing the PCB	8
4.1.4 Replacing the Dual Compressor	9
4.1.5 Replacing the Motor	10
4.1.6 Replacing the Air Tube Connector	10
4.1.7 Replacing the Bottom Housing	11
4.1.8 Replacing the Tube Subassembly	12
4.1.9 Replacing the IEC Socket	12
4.2 SoftCloud Top/Air	13
4.2.1 Replacing the Air Filter	13
4.2.2 Replacing the Top Housing	13
4.2.3 Replacing the PCB	14
4.2.4 Replacing the Compressor	15
4.2.5 Replacing the Motor	16
4.2.6 Replacing the Air Tube Connector	17
4.2.7 Replacing the Bottom Housing	18
4.2.8 Replacing the Tube Subassembly	19
4.2.9 Replacing the IEC Socket	19
5 Service Mattress	20
5.1 Replacing the Air Cell Set	20
5.2 Replacing the Heel Cell (Ace/Pro)	22
5.3 Replacing the Side Bolster (Pro)	23

1 General

1.1 Introduction

This document contains important information about assembly, adjustment and advanced maintenance of the product. To ensure safety when handling the product, read this document and the user manual carefully and follow the safety instructions.

Find the user manual on Invacare's website or contact your Invacare representative. See addresses at the end of this document.

Invacare reserves the right to alter product specifications without further notice.

Before reading this document, make sure you have the latest version. You find the latest version as a PDF on the Invacare website.

For pre-sale and user information, see the user manual.

For more information about the product, for example product safety notices and product recalls, contact your Invacare representative. See addresses at the end of this document.

1.2 Symbols in This Manual

Symbols and signal words are used in this document and apply to hazards or unsafe practices which could result in personal injury or property damage. See the information below for definitions of the signal words.



WARNING!

Indicates a hazardous situation that could result in serious injury or death if it is not avoided.



CAUTION!

Indicates a hazardous situation that could result in minor or slight injury if it is not avoided.



NOTICE!

Indicates a hazardous situation that could result in damage to property if it is not avoided.



Tips and Recommendations

Gives useful tips, recommendations, and information for efficient, trouble-free use.



Triman

Indicates recycling and sorting rules (only relevant for France).

1.3 Preliminary System Check



Before commencing any service procedure, the following preliminary verifications should be completed to ensure the system fault or failure is not due to a user oversight.

1. Confirm the mains cable is firmly attached and the system is connected to a working power source.
2. Make sure the handle is secured to the control unit. All three connectors should be firmly inserted.
3. Remove the mattress top cover. Ensure the cardiopulmonary resuscitation (CPR) label is firmly attached.
4. Check that each air cell and side bolster is firmly attached to the internal air tubes.

Once the preliminary system check is complete, proceed with the service and repair as outlined in the following procedures.

2 Safety

2.1 General Safety Information

WARNING!
Risk of injury or damage to property

- The procedures in this manual must only be performed by a qualified technician.
- Use only original accessories and spare parts.
- Do not handle this product or any available optional equipment without first completely reading and understanding these instructions and any additional instructional material such as user manuals, installation manuals or instruction sheets supplied with this product or optional equipment.
- After each assembly, check that all fittings are properly tightened and that all parts have the correct function.

WARNING!
Risk of contamination

- Clean and disinfect the product before servicing.

NOTICE!

Assembly of accessories might not be described in this service manual. Refer to the manual, delivered with the accessory.

- Additional manuals can be ordered from Invacare. See addresses at the end of this document.

NOTICE!

Replacement parts for this product family are only available as a kit. Always use the complete new kit when replacing a part.

- Spare parts kits can be ordered from Invacare. Refer to your local Invacare website to access the electronic spare parts catalogue (ESPC).

NOTICE!

Refer to the user manual of this product for information on:

- Technical Data
- Product Components
- Labels
- Additional safety instructions
- Cleaning and disinfection instructions

NOTICE!

When components are replaced, it is necessary to ensure their traceability by keeping the original serial number in the control unit (replacement of spare parts with serial numbers).

- Ensure the serial number traceability by either printing a new serial label or transferring the existing one, and placing it in the replacement part.



The information contained in this document is subject to change without notice.

2.2 Personal Safety Information

These safety instructions are intended to help avoid accidents during work and must be observed under all circumstances.

All employees coming into contact with contaminated products must regularly consult a company doctor. Work clothing and personal protective equipment must be available in necessary quantities and be in proper condition. Reliable hand and surface disinfection must be ensured.

WARNING!
Risk of contamination

- Clean and disinfect the product before carrying out repairs.

2.3 Electrical Safety Check



NOTICE!

Regular electrical checks according to EN 62353 (VDE0751) must be carried out in line with national requirements.

Inspect all electronic components for damage to the casing or cable, test functions and check for stray current.

3 Digital Control Unit

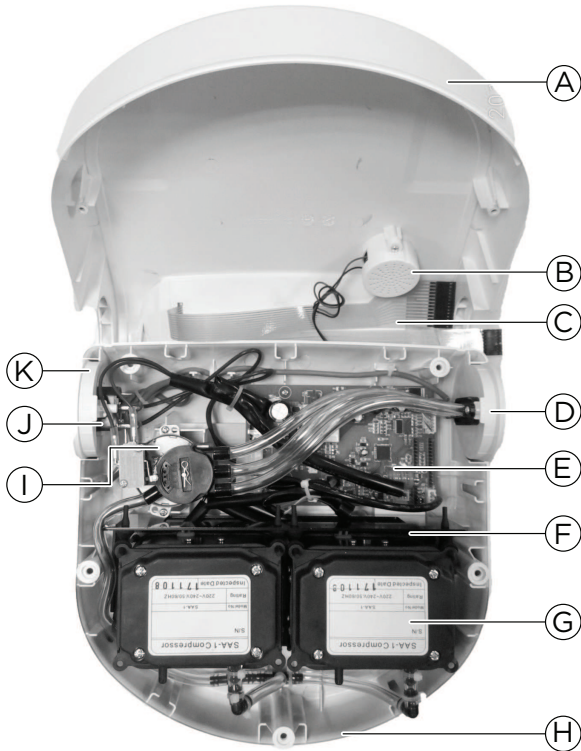
3.1 Components' Overview



A	Top Housing
B	Speaker bracket
C	Control panel
D	Air tube connector
E	Circuit board (PCB)
F	Compressor bracket
G	Compressor (dual compressor on the above illustrated Ace/Pro models, single compressor on the Top/Air models)
H	Bottom housing
I	Motor
J	IEC1 Mains socket
K	IEC Mains socket fixture

3.2 Circuit Board (PCB) Overview

3.2.1 Ace/Pro PCB

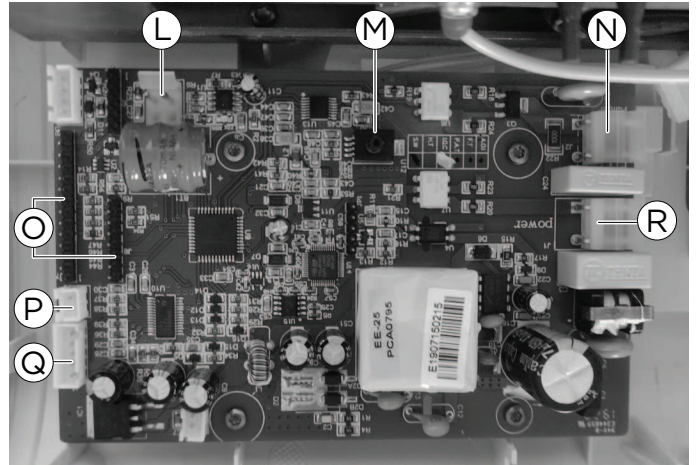

L	Power switch connector
M	Pressure sensor
N	Compressor connector
O	Flexible printed circuit (FPC) connectors
P	Speaker connector
Q	Motor connector
R	IEC Mains connector

3.2.2 Top/Air PCB

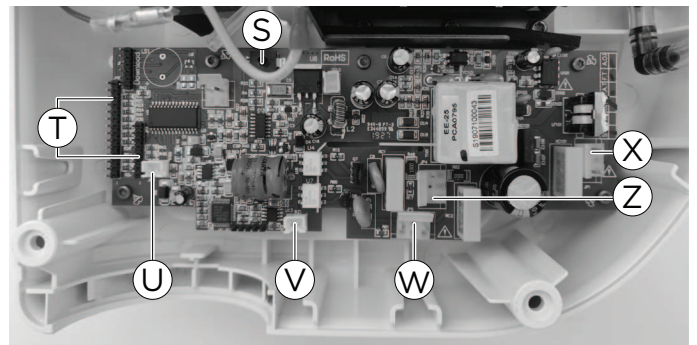

S	Pressure sensor
T	Flexible printed circuit (FPC) connectors
U	Power switch connector
V	Speaker connector
X	Motor connector
Y	Compressor connector
Z	IEC Mains connector

¹ International Electrotechnical Commission Standards

4 Service | Digital Control Unit



Service Due

After the control unit has been running for 8760 hours, the LED with **service due** will be activated with yellow light, where the service technician should maintain the device.

To reset the service LED, press the MUTE button for 4 seconds to shut down the service LED and the system will continue to count the next 8760 hours automatically.

4.1 SoftCloud Ace/Pro

4.1.1 Replacing the Air Filter

Refers to spare parts kit SP1631536



NOTICE!

Good filter maintenance is critical to maintaining your mattress system in optimal operating condition. Failure to keep the filters clean will result in system downtime and increase repair costs.

It is recommended that the air filter be replaced annually. Replacement air filters are available from an Invacare Service Centre.

1. Switch off the control unit and disconnect from mains supply.
2. Disconnect the air hoses.
3. Place the control unit on a flat surface with its back panel facing upward (place a soft cloth under the unit to prevent scratches).
4. While keeping the hanger brackets apart, carefully remove both air filter covers and their respective filters (A). Discard the filters.
5. Open the spare parts kit and carefully place a new filter in each of the covers.
6. Place the air filter covers back into the control units' slots.



4.1.2 Replacing the Top Housing

Refers to spare parts kit SP1631544

NOTICE!
Risk of damaging the PCB by electrostatic discharge
 Handle PCBs only in Electrostatic Protected Areas

 T10, T20 Torx keys

Removing Housing

1. Switch off the control unit and disconnect from mains supply.
2. Turn the unit upside down.
3. Loosen and remove the five screws **A** with the appropriate Torx key.
4. Hold the unit firmly. Turn the unit back to its top side.
5. Open the housing. Unplug the speaker wire **B**, and FPCs **C** and **D**.
6. Detach the housing.

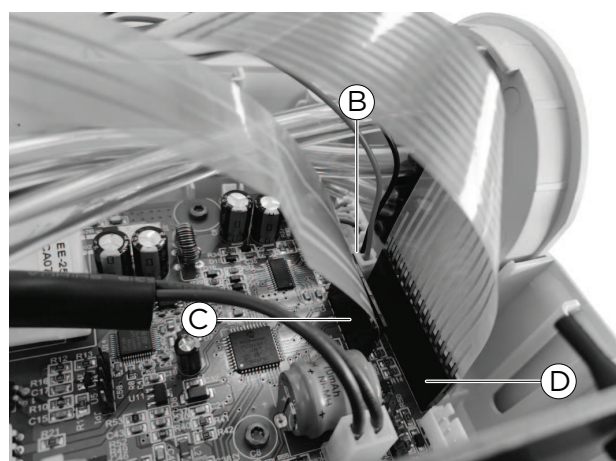

Preparing Housing

7. Open the spare parts kit. Use the old housing as a guide, and apply the fuse type and insulation class stick-on labels on the new housing.
8. Assemble the new speaker with its bracket and foam pad, and place it on the housing. Fix it with the two provided screws.
9. Place both foam strips on the new housing. Make sure they are set between the housing and the dual compressor (use the old housing as reference).
10. Thread both FPC's through the housing's slit and stick the digital control panel on the front of the housing.



Installing Housing

11. Plug both FPC's and the speaker cable.
12. Install the new housing. Ensure no cable or tube is kinked or clamped.
13. Hold the unit firmly. Turn it upside down.
14. Install the five provided screws and tighten the new housing.

4.1.3 Replacing the PCB

Refers to spare parts kits: SP1633122 (240V) / SP1633116 (110V)

NOTICE!
Risk of damaging the PCB by electrostatic discharge
 Handle PCBs only in Electrostatic-Protected Areas

 T10, T20 Torx keys
 Wire clippers

1. Switch off the control unit and disconnect from mains supply.
2. Detach the top housing, the speaker cable and both FPCs (see 4.1.2).
3. Cut the cable tie that holds tube © to the bottom housing. Disconnect the three air tubes (A), (B), and ©.

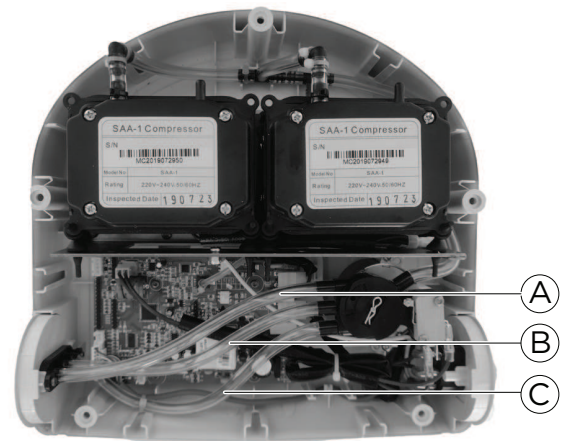

4. Unplug the motor cable (D), the power switch cable (E) the compressor cable (F), and the mains cable (G).
5. Cut the cable tie securing the pressure sensor (H) and remove it.

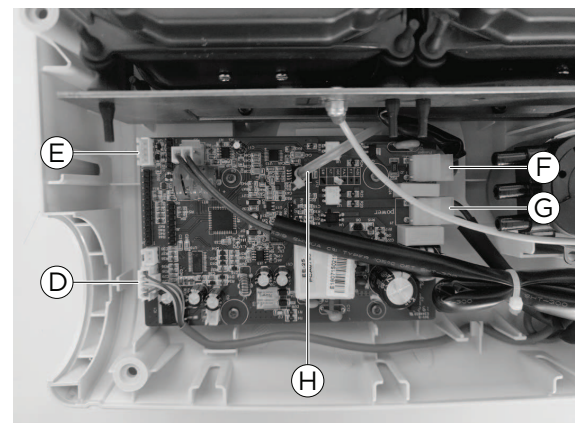

6. Loosen and remove the four screws I using the appropriate Torx key.
7. Discard the nonfunctioning PCB.
8. Install the new PCB and secure it with the four provided screws.
9. Install all the parts in reverse order. Ensure no cable or tube is kinked or clamped. Use the provided cable ties to secure tube © and pres-sure sensor (H). Cut the excess cable tie length.
10. Reinstall the housing. Ensure no cable or tube is kinked or clamped.

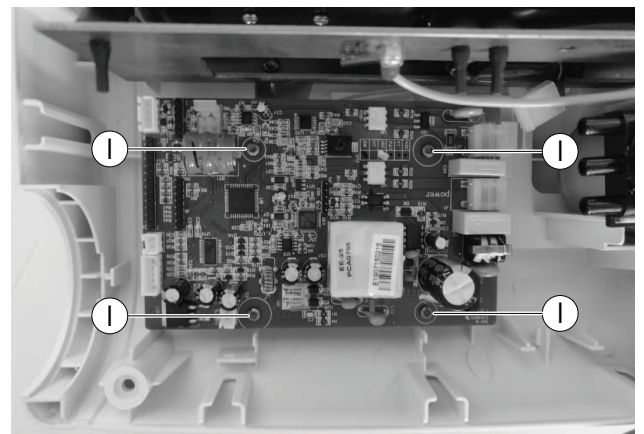

4.1.4 Replacing the Dual Compressor

Refers to spare parts kit SP1631542

NOTICE!
Risk of damaging the PCB by electrostatic discharge
 Handle PCBs only in Electrostatic-Protected Areas

 T10, T20 Torx keys
 Wire clippers

1. Switch off the control unit and disconnect from mains supply.
2. Detach the top housing, the speaker cable and both FPCs (see 4.1.2).
3. Disconnect the three air tubes and cut the cable tie that holds the third tube to the bottom housing (see 4.1.3).
4. Unplug the compressor cable from the PCB (see 4.1.3).
5. Unplug the yellow earth wire **A** from its socket.

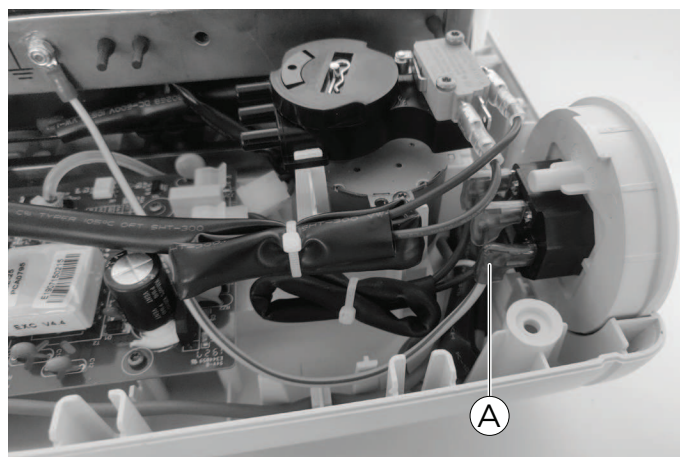

6. Carefully cut both cable ties **B** securing the air tubes to the dual compressor and unplug them.

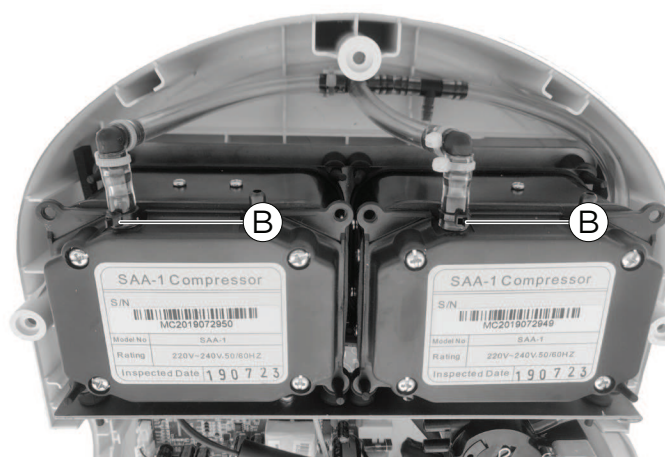

7. Loosen and remove the eight screws **C** fixing the compressor bracket.
8. Remove the nonfunctioning dual compressor and discard it.
9. Install the new dual compressor and fix it with the eight provided screws.
10. Plug the compressor cable and the earth wire.
11. Install the air tubes and secure them with the provided cable ties. Cut the excess cable tie length.
12. Install the air tubes into the motor. Use the provided cable tie to secure the third tube. Cut the excess cable tie length.
13. Reinstall the housing. Ensure no cable or tube is kinked or clamped.

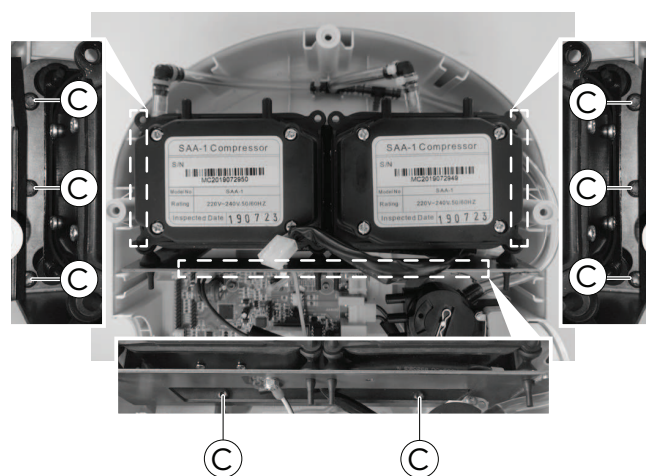

4.1.5 Replacing the Motor

Refers to spare parts kit SP1631534

NOTICE!
Risk of damaging the PCB by electrostatic discharge
 Handle PCBs only in Electrostatic-Protected Areas

 T10, T20 Torx keys
 Wire clippers

1. Switch off the control unit and disconnect from mains supply.
2. Detach the top housing, the speaker cable and both FPCs (see 4.1.2).
3. Remove the three air tubes and cut the cable tie that holds the tube which is secured to the bottom housing (see 4.1.3).
4. Unplug the air tube **A** which connects the motor to the dual compressor.
5. Unplug the power switch cable and the motor cable from the PCB (see 4.1.3).
6. Loosen and remove the two screws **B** with the appropriate Torx key.
7. Remove and discard the nonfunctioning motor.
8. Install the new motor and its screws. Tighten the screws.
9. Plug the motor and power switch cables, and install the air tubes into the motor. Use the provided cable tie to secure the third tube. Cut the excess cable tie length.
10. Reinstall the housing. Ensure no cable or tube is kinked or clamped.

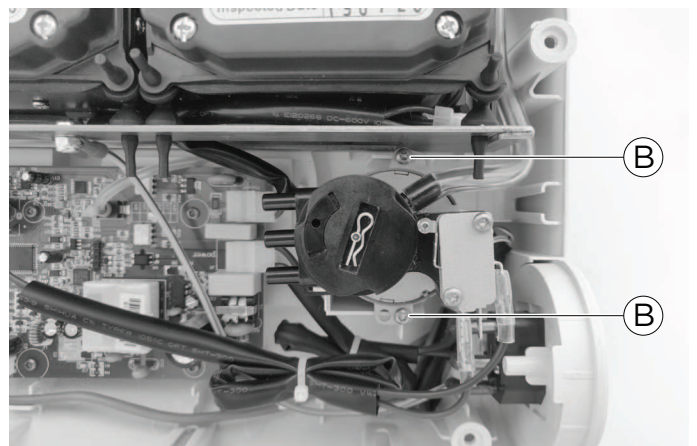
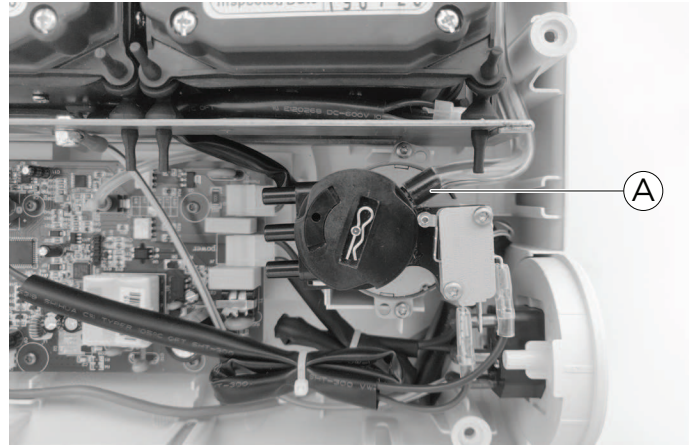

4.1.6 Replacing the Air Tube Connector

Refers to spare parts kit SP1631535

NOTICE!
Risk of damaging the PCB by electrostatic discharge
 Handle PCBs only in Electrostatic-Protected Areas

 T10, T20 Torx keys

1. Switch off the control unit and disconnect from mains supply.
2. Detach the top housing, the speaker cable and both FPCs (see 4.1.2).
3. Hold the connector assembly firmly with one hand. Remove all the air tubes **A**, **B** and **C** from the connector.

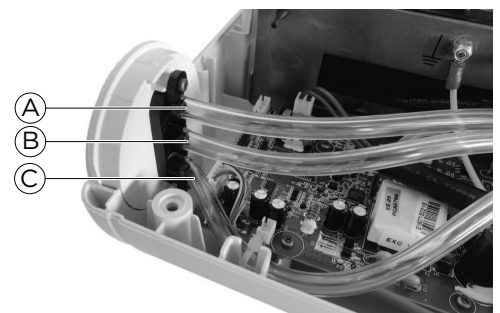

4. Loosen and remove the screws ① with the appropriate Torx key.
5. Discard both the nonfunctioning connector and the bracket.
6. Install the new ones and tighten them with the two provided screws.
7. Reattach the air tubes to the connector. Ensure to install the tubes in the correct sequence.
8. Place the connector assembly on the bottom housing. Ensure that tube ③ is the one at the bottom.
9. Reinstall the top housing. Ensure no cable or tube is kinked or clamped.





4.1.7 Replacing the Bottom Housing

Refers to spare parts kit SP1631540

! **NOTICE!**
The replacement of the bottom housing shall be performed by Invacare-trained personnel only.

! **NOTICE!**
Risk of damaging the PCB by electrostatic discharge
Handle PCBs only in Electrostatic-Protected Areas

-  T10, T20 Torx keys
-  Wire clippers

1. Switch off the control unit and disconnect from mains supply.
2. Detach the top housing, the speaker cable and both FPCs (see 4.1.2).
3. Cut the cable tie ① that holds the tube to the bottom housing.
4. Unplug the power switch and motor cables from the PCB (see 4.1.3).
5. Loosen and remove the two motor screws with the appropriate Torx key (see 4.1.5).
6. Unplug the compressor and mains cables from the PCB (see 4.1.3).
7. Loosen and remove the four PCB screws with the appropriate Torx key (see 4.1.3).
8. Cut the cable tie that holds the compressor T-valve to the bottom housing.
9. Loosen and remove the eight compressor screws with the appropriate Torx key (see 4.1.4).
10. Remove - from the bottom housing - the dual compressor (in its L-shaped bracket), the PCB, the motor, the air tube connector, and the power switch connector.
11. Ensure the serial number traceability by either printing a new serial label or transferring the existing one, and placing it in the replacement bottom housing. Install the blue label on top of the serial label, ensuring the latter stays visible through it.

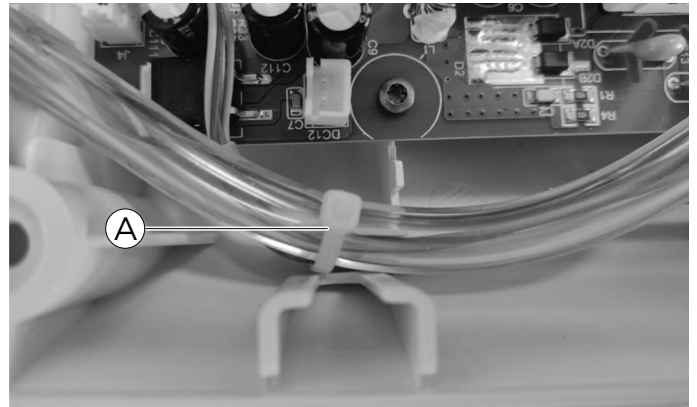



12. Pick up the new bottom housing and place the components in the reverse order to which they have been removed from the old one. Make sure the small silicone tube goes under the compressor bracket.
13. Using the provided cable ties, secure the T-valve and the tube  to the new bottom housing. Cut the excess cable tie length.
14. Reconnect all cables to the PCB.
15. Reinstall the top housing. Ensure no cable or tube is kinked or clamped.

4.1.8 Replacing the Tube Subassembly

Refers to spare parts kit SP1633185

! **NOTICE!**
Risk of damaging the PCB by electrostatic discharge
 Handle PCBs only in Electrostatic-Protected Areas



 T10, T20 Torx keys
 Wire clippers

1. Switch off the control unit and disconnect from mains supply.
2. Detach the top housing, the speaker cable and both FPC's (see 4.1.2).
3. Cut the cable tie that holds the compressor T-valve to the bottom housing.
4. Carefully remove the cable ties that are securing the air tubes (see 4.1.4).
5. Unplug the air tube that connects the dual compressor and the motor.
6. Remove the old tubing set and replace it with the new one.
7. Plug the air tube to the motor and the air tubes from the T-valve to the dual compressor. Secure the connections with cable ties. Cut the excess cable tie length.
8. Re-install the top housing.

4.1.9 Replacing the IEC Socket

Refers to spare parts kit SP1631538

! **NOTICE!**
Risk of damaging the PCB by electrostatic discharge
 Handle PCBs only in Electrostatic-Protected Areas

 PH1 Philips Key
 T20 Torx key
 Wire clippers

1. Switch off the control unit and disconnect from mains supply.
2. Detach the top housing, the speaker cable and both FPCs (see 4.1.2).
3. Unplug the mains cable from the PCB (see 4.1.3).
4. Disconnect the yellow earth wire from its socket (see 4.1.4).
5. Install the new socket, plug the mains cable into the PCB, and plug the earth wire into the new socket.
6. Reinstall the top housing. Ensure no cable or tube is kinked or clamped.

4.2 SoftCloud Top/Air

4.2.1 Replacing the Air Filter

Refers to spare parts kit SP1631448

! NOTICE!
 Good filter maintenance is critical to maintaining your mattress system in optimal operating condition. Failure to keep the filters clean will result in system downtime and increase repair costs. It is recommended that the air filter be replaced annually. Replacement air filters are available from an Invacare Service Centre.

1. Switch off the control unit and disconnect from mains supply.
2. Disconnect the air hoses.
3. Place the control unit on a flat surface with its back panel facing upward (place a soft cloth under the unit to prevent scratches).
4. While keeping the hanger brackets apart, carefully remove both air filter covers and their respective filters (A). Discard the filters.
5. Open the spare parts kit and carefully place a new filter in each of the covers.
6. Place the air filter covers back into the control units' slots.



4.2.2 Replacing the Top Housing

Refers to spare parts kit SP1631543

! NOTICE!
Risk of damaging the PCB by electrostatic discharge
 Handle PCBs only in Electrostatic-Protected Areas

T10, T20 Torx keys

Removing Housing

1. Switch off the control unit and disconnect from mains supply.
2. Turn the unit upside down.
3. Loosen and remove the five screws (A) with the appropriate Torx key.
4. Hold the unit firmly. Turn the unit back to its top side.



5. Open the housing. Unplug the speaker wire (B), and FPCs (C) and (D).
6. Detach the housing.

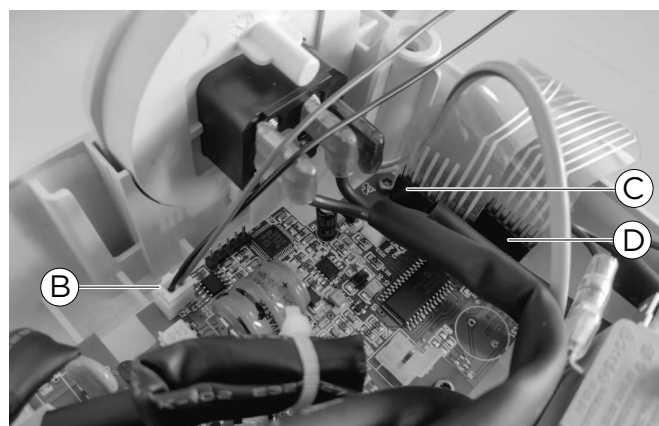

Preparing Housing

7. Open the spare parts kit. Use the old housing as a guide, and apply the fuse type and insulation class stick-on labels on the new housing.
8. Assemble the new speaker with its bracket and foam pad, and place it on the housing. Fix it with the two provided screws.
9. Place both foam strips on the new housing. Make sure they are set between the housing and the dual compressor (use the old housing as reference).
10. Thread both FPC's through the housing's slit and stick the digital control panel on the front of the housing.



Installing Housing

11. Plug both FPC's and the speaker cable.
12. Install the new housing. Ensure no cable or tube is kinked or clamped.
13. Hold the unit firmly. Turn it upside down.
14. Install the five provided screws and tighten the new housing.

4.2.3 Replacing the PCB

Refers to spare parts kits: SP1633122 (240V) / SP1633116 (110V)

! **NOTICE!**
Risk of damaging the PCB by electrostatic discharge
 Handle PCBs only in Electrostatic-Protected Areas

 T10, T20 Torx keys
 Wire cutters

1. Switch off the control unit and disconnect from mains supply.
2. Detach the top housing, the speaker cable and both FPCs (see 4.1.2).
3. Unplug the power switch cable (A), motor cable (B), compressor cable (C) and mains cable (D).
4. Cut the cable tie of the pressure sensor (E) and remove it.

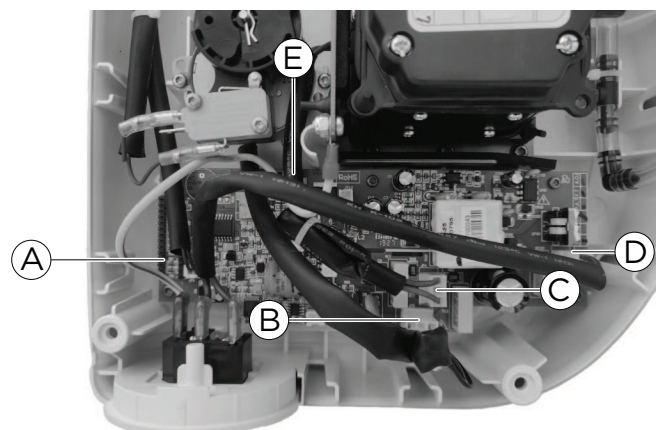

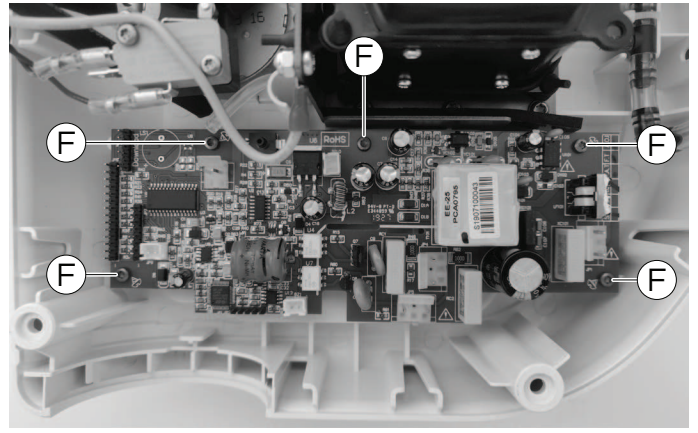

5. Loosen and remove the five screws F with the appropriate Torx key.
6. Replace the nonfunctioning PCB and secure the new one with the five provided screws.
7. Plug the power switch cable, motor, compressor, and mains cables.
8. Plug the sensor tube (E) and secure it with a cable tie. Cut the excess cable tie length.
9. Install the housing. Ensure no cable or tube is kinked or clamped.



4.2.4 Replacing the Compressor

Refers to spare parts kit SP1631541

! **NOTICE!**
Risk of damaging the PCB by electrostatic discharge
 Handle PCBs only in Electrostatic-Protected Areas

-  T20 Torx keys
-  Wire clippers

1. Switch off the control unit and disconnect from mains supply.
2. Detach the top housing, the speaker cable and both FPCs (see 4.2.2).
3. Unplug the compressor cable from the PCB (see 4.2.3).
4. Using the wire clippers, cut the cable tie securing the wires.
5. Carefully remove the cable tie securing the air tube A and unplug the tube.

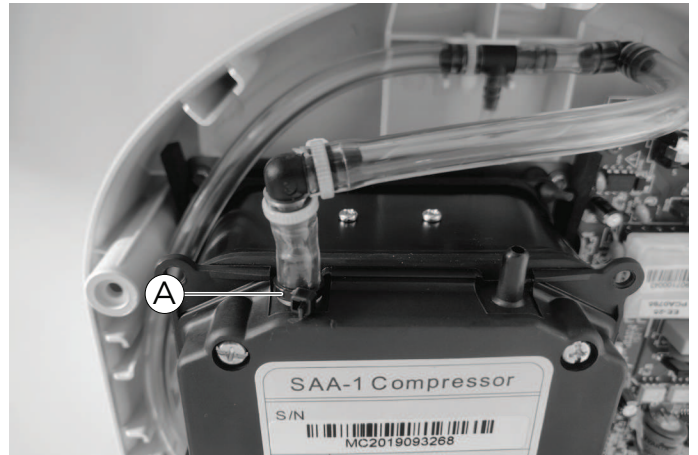

6. Loosen and remove the six screws (B).

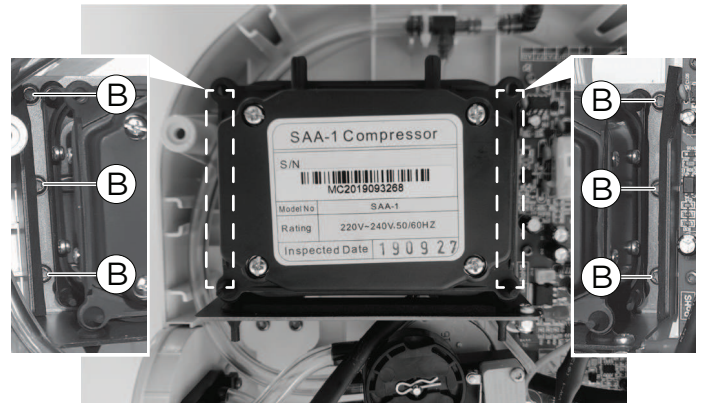

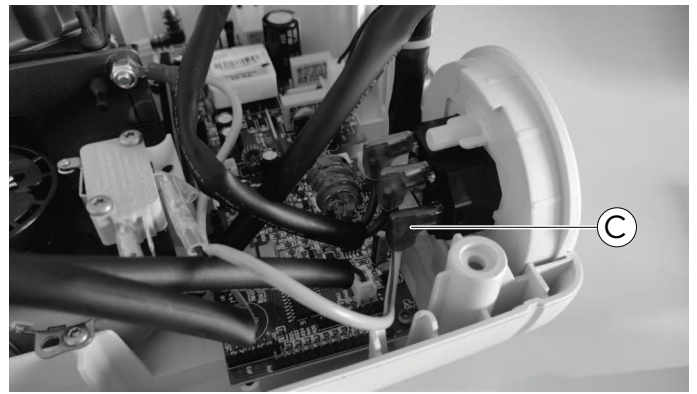

7. Unplug the yellow earth wire © from its socket.
8. Remove the nonfunctioning dual compressor and install the new one.
9. Install the six provided screws and tighten them.
10. Plug the compressor cable and the earth wire.
11. Install the air tubes and secure them with the provided cable ties. Cut the excess cable tie length.
12. Reinstall the housing. Ensure no cable or tube is kinked or clamped.



4.2.5 Replacing the Motor

Refers to spare parts kit SP1631534

NOTICE!
Risk of damaging the PCB by electrostatic discharge
 Handle PCBs only in Electrostatic-Protected Areas

 T10, T20 Torx keys
 Wire clippers

1. Switch off the control unit and disconnect from mains supply.
2. Detach the top housing, the speaker cable and both FPCs (see 4.2.2).
3. Remove the three air tubes (A), (B) and (C).
4. Unplug the power switch cable and the motor cable from the PCB (see 4.2.3).
5. Loosen and remove the two screws (D) with the appropriate Torx key.
6. Remove the motor.
7. Install the new motor and its screws. Tighten the screws.
8. Plug the air tubes (A), (B), and (C), and the cables into the PCB.
9. Reinstall the housing. Ensure no cable or tube is kinked or clamped.

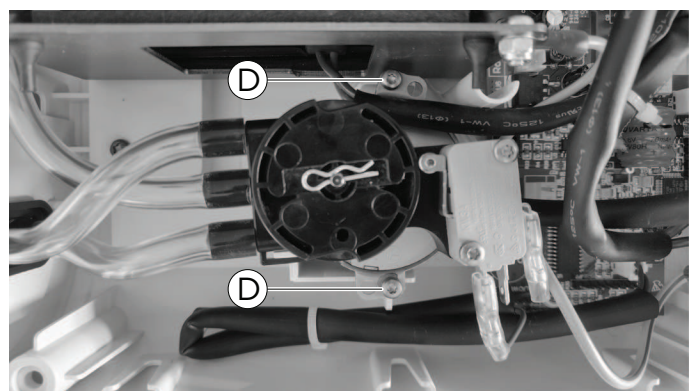
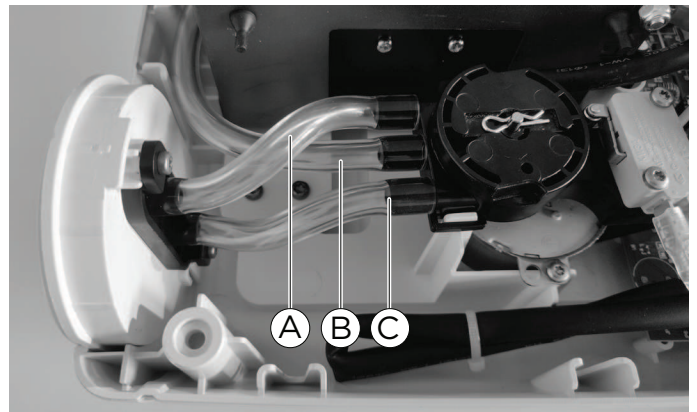

4.2.6 Replacing the Air Tube Connector

Refers to spare parts kit SP1631447

NOTICE!
Risk of damaging the PCB by electrostatic discharge
 Handle PCBs only in Electrostatic-Protected Areas

 T10, T20 Torx keys

1. Switch off the control unit and disconnect from mains supply.
2. Detach the top housing, the speaker cable and both FPCs (see 4.2.2).
3. Hold the connector assembly firmly with one hand. Remove both the air tubes **A** and **B** from the connector.
4. Loosen and remove the screws **C** with the appropriate Torx key.
5. Discard both the nonfunctioning connector and the bracket.
6. Install the new ones and tighten them with the two provided screws.
7. Reattach the air tubes to the connector. Ensure to install the tubes in the correct sequence.
8. Place the connector assembly on the bottom housing. Ensure that tube **B** is the one at the bottom.
9. Reinstall the top housing. Ensure no cable or tube is kinked or clamped.

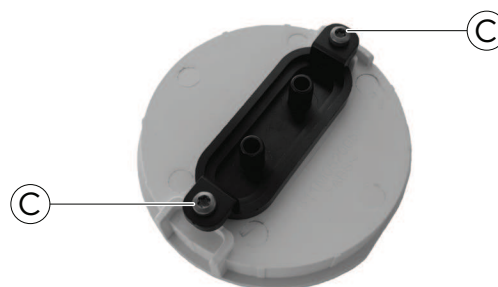
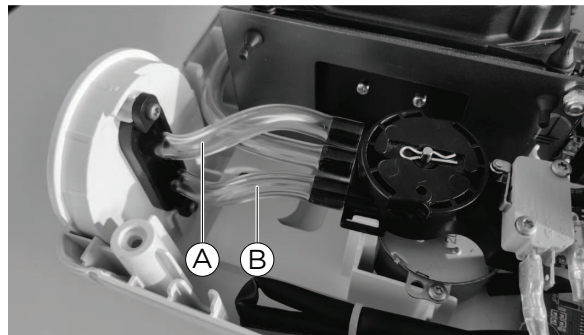



4.2.7 Replacing the Bottom Housing

Refers to spare parts kit SP1631452

! **NOTICE!**
The replacement of the bottom housing shall be performed by Invacare-trained personnel only.

! **NOTICE!**
Risk of damaging the PCB by electrostatic discharge
Handle PCBs only in Electrostatic-Protected Areas

 T10, T20 Torx keys
 Wire clippers

1. Switch off the control unit and disconnect from mains supply.
2. Detach the top housing, the speaker cable and both FPCs (see 4.2.2).
3. Unplug the power switch and motor cables from the PCB (see 4.2.3).
4. Loosen and remove the two motor screws with the appropriate Torx key (see 4.2.5).
5. Unplug the compressor and mains cables from the PCB (see 4.2.3).
6. Loosen and remove the four PCB screws with the appropriate Torx key (see 4.2.3).
7. Cut the cable tie that holds the compressor T-valve to the bottom housing.
8. Loosen and remove the eight compressor screws with the appropriate Torx key (see 4.2.4).
9. Remove - from the bottom housing - the dual compressor (in its L-shaped bracket), the PCB, the motor, the air tube connector, and the power switch connector.
10. Ensure the serial number traceability by either printing a new serial label or transferring the existing one, and placing it in the replacement bottom housing. Install the blue label on top of the serial label, ensuring the latter stays visible through it.
11. Pick up the new bottom housing and reassemble in the reverse order to which they have been removed from the old one. Make sure the small silicone tube goes under the compressor bracket.
12. Using the provided cable ties, secure the T-valve and the tube  to the new bottom housing. Cut the excess cable tie length.
13. Reconnect all cables to the PCB.
14. Reinstall the top housing. Ensure no cable or tube is kinked or clamped.

4.2.8 Replacing the Tube Subassembly

Refers to spare parts kit SP1633186

! **NOTICE!**
Risk of damaging the PCB by electrostatic discharge
 Handle PCBs only in Electrostatic-Protected Areas

 T10, T20 Torx keys
 Wire clippers

1. Switch off the control unit and disconnect from mains supply.
2. Detach the top housing, the speaker cable and both FPCs (see 4.2.2).
3. Cut the cable tie that holds the compressor T-valve to the bottom housing.
4. Carefully remove the cable ties that are securing the air tubes (see 4.2.4).
5. Unplug the air tube that connects the dual compressor and the motor.
6. Remove the old tubing set and replace it with the new one.
7. Plug the air tube to the motor and the air tubes from the T-valve to the dual compressor. Secure the connections with cable ties. Cut the excess cable tie length.
8. Reinstall the top housing. Ensure no cable or tube is kinked or clamped.

4.2.9 Replacing the IEC Socket

Refers to spare parts kit SP1631538

! **NOTICE!**
Risk of damaging the PCB by electrostatic discharge
 Handle PCBs only in Electrostatic-Protected Areas

 PH1 Philips Key
 T20 Torx key
 Wire clippers

1. Switch off the control unit and disconnect from mains supply.
2. Detach the top housing, the speaker cable and both FPCs (see 4.2.2).
3. Unplug the mains cable from the PCB (see 4.2.3).
4. Unplug the yellow earth wire from its socket (see 4.2.4).
5. Install the new socket, plug the mains cable into the PCB, and plug the earth wire into the new socket.
6. Reinstall the top housing. Ensure no cable or tube is kinked or clamped.

5 Service | Mattress

5.1 Replacing the Air Cell Set

Refers to spare parts kit SP1633189, SP1633190, SP1633192, SP1633193, SP1633194, SP1633195, SP1633196, SP1633197, SP1633203, SP1633204, SP1633205, SP1633206

 Wire clippers

1. Switch off the control unit and disconnect from mains supply.
2. Open the zipper of the bed cover and take off the top cover.



3. Unplug the snap fasteners that connect the defective air cell to the two longitudinal bolsters - one on each side.



4. Facing towards the mattress, on the left-hand side, two L-shaped blue tubes connect the air cell to the bolster on that side. Using the wire clippers, cut both cable ties **A** securing them.
5. Carefully cut the end of the L-shaped tube connected to the side bolster using the wire cutters and unplug it.

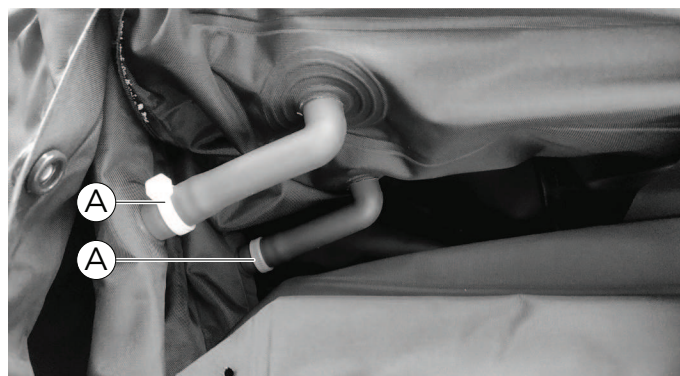

6. Remove the defective air cell by sliding it out of the mattress and discard it.
7. Install the new air cell in place.
8. Slightly brush off any existing dust from the side bolster's holder and plug the the new cell's L- shaped tubes into their respective holders.
9. Secure the tubes with the provided cable ties. Cut the excess cable tie length.
10. Plug the snap fasteners on both sides to fix the air cell in its place.



11. Put the top cover back in place and close the zipper.



5.2 Replacing the Heel Cell (Ace/Pro)

Refers to spare parts kit SP1633198, SP1633199, SP1633200, SP1633201, SP1633207, SP1633208

 Wire clippers

1. Switch off the control unit and disconnect from mains supply.
 2. Open the bed cover zipper and take off the top cover (see 5.1).
 3. The heel cells are located at the foot end of the mattress (there are five heel cells in total).
 4. Unplug the snap fasteners connecting the defective heel cell to the two longitudinal bolsters - one on each side.
-
5. Facing towards the mattress, on the left-hand side, two L-shaped blue tubes are connecting the heel cell to the side bolster. Using the wire clippers, cut the two cable ties A securing them.
 6. Carefully cut the end of the L-shaped tube connected to the side bolster using the wire cutters and unplug it.
 7. Remove the defective heel cell by sliding it out of the mattress and discard it.
 8. Slightly brush off any existing dust from the side bolster's holder and plug the L-shaped tube of the new cell into its holders.
 9. Secure the tubes with the provided cable ties. Cut the excess cable tie length.
 10. Plug the snap fasteners on both sides to fix the heel cell in place.
 11. Put the top cover back in place and close the zipper (see the image in 5.1, point 11).



5.3 Replacing the Side Bolster (Pro)

Refers to spare parts kit SP1633209, SP1633210

 Wire clippers

1. Switch off the control unit and disconnect from mains supply.
2. Open the zipper of the bed cover and take off the top cover (see the image in 5.1, point 1 and 2).
3. Unplug all twenty-two snap fasteners connecting the air cells to the defective side bolster.
4. Using the wire clippers, cut cable tie **A** securing the upper L-shaped blue tube, connecting the head cell to the side bolster and unplug it. Repeat this procedure for the remaining two head cells (there are three in total).
5. Unplug the four snap fasteners that secure the side bolster to the mattress' bottom cover.
6. Discard the defective side bolster.
7. Install the new side bolster in place by following, in reverse order, the process described on points 3. to 5. Secure the tubes with the provided cable ties. Cut the excess cable tie length.
8. Put the top cover back in place and close the zipper (see the image in 5.1, point 11).



**United Kingdom & Ireland:**

Invacare Limited
Pencoed Technology Park, Pencoed
Bridgend CF35 5AQ
Tel: (44) (0) 1656 776 200
uk@invacare.com
www.invacare.co.uk

Belgium & Luxemburg:

Invacare nv
Autobaan 22
B-8210 Loppem
Tel: (32) (0)50 83 10 10
Fax: (32) (0)50 83 10 11
marketingbelgium@invacare.com
www.invacare.be

Danmark:

Invacare A/S
Sdr. Ringvej 37
DK-2605 Brøndby
Tel: (45) (0)36 90 00 00
Fax: (45) (0)36 90 00 01
denmark@invacare.com
www.invacare.dk

Deutschland:

Invacare GmbH
Am Achener Hof 8
D-88316 Isny
Tel: (49) (0)7562 700 0
kontakt@invacare.com
www.invacare.de

Österreich:

Invacare Austria GmbH
Herzog-Odilo-Straße 101
A-5310 Mondsee
Tel: (43) 6232 5535 0
Fax: (43) 6232 5535 4
info-austria@invacare.com
www.invacare.at

Schweiz / Suisse / Svizzera:

Invacare AG
Neuhofweg 51
CH-4147 Aesch BL
Tel: (41) (0)61 487 70 80
Fax: (41) (0)61 488 19 10
switzerland@invacare.com
www.invacare.ch

España:

Invacare S.A.
Avenida del Oeste, 50 – 1º-1a
Valencia-46001
Tel: (34) 972 493 214
contactsp@invacare.com
www.invacare.es

France:

Invacare Poirier SAS
Route de St Roch
F-37230 Fondettes
Tel: (33) (0)2 47 62 64 66
contactfr@invacare.com
www.invacare.fr

Italia:

Invacare Mecc San s.r.l.,
Via dei Pini 62,
I-36016 Thiene (VI)
Tel: (39) 0445 38 00 59
servizioclienti@invacare.com
www.invacare.it

Nederland:

Invacare BV
Galvanistraat 14-3
NL-6716 AE Ede
Tel: (31) (0)318 695 757
nederland@invacare.com
www.invacare.nl

Norge:

Besøksadresse:
(Office addresses)
Invacare AS
Brynsveien 16
0667 Oslo
Tel: (47) 22 57 95 00
norway@invacare.com
www.invacare.no

Norge:

Vareleveringsadresse:
(Storage / Teknical dep)
Østensjøveien 19
0661 Oslo
eknisk@invacare.com
www.invacare.no

Portugal:

Invacare Lda
Rua Estrada Velha, 949
P-4465-784 Leça do Balio
Tel: (351) (0)225 193 360
portugal@invacare.com
www.invacare.pt

Suomi:

Camp Mobility
Patamäenkatu 5, 33900 Tampere
Puhelin 09-35076310
info@campmobility.fi
www.campmobility.fi

Sverige:

Invacare AB
Fagerstagatan 9
S-163 53 Spånga
Tel: (46) (0)8 761 70 90
Fax: (46) (0)8 761 81 08
sweden@invacare.com
www.invacare.se

EU Export:

Invacare Poirier SAS
Route de St Roch
F-37230 Fondettes
Tel: (33) (0)2 47 62 69 80
serviceclient_export@invacare.com
www.invacare.eu.com

Australia:

Invacare Australia Pty. Ltd.
Unit 18/12 Stanton Road, Seven Hills
NSW 2147, Australia
Phone: 1800 460 460
Fax: 1800 814 367
orders@invacare.com.au
www.invacare.com.au

New Zealand:

Invacare New Zealand
Ltd4 Westfield Place
Mt Wellington
1060, New Zealand
Phone: 0800 468 222
Fax: 0800 807 788
sales@invacare.co.nz
www.invacare.co.nz

USA:

Invacare Corporation
One Invacare Way
Elyria, Ohio USA
44035
800-333-6900
www.invacare.com



Invacare UK Operations Limited
Unit 4, Pencoed Technology Park, Pencoed
Bridgend CF35 5AQ
UK



Invacare Portugal, Lda
Rua Estrada Velha 949
4465-784 Leça do Balio
Portugal

